

Nick Hamshaw and Elaine Dorsett

Cambridge International
AS & A Level Mathematics:

Mechanics

Worked Solutions Manual



Contents

How to use this resource

1 Velocity and acceleration

Exercise 1A

Exercise 1B

Exercise 1C

Exercise 1D

Exercise 1E

Exercise 1F

End-of-chapter review exercise 1

2 Force and motion in one dimension

Exercise 2A

Exercise 2B

Exercise 2C

Exercise 2D

End-of-chapter review exercise 2

3 Forces in two dimensions

Exercise 3A

Exercise 3B

Exercise 3C

Exercise 3D

Exercise 3E

End-of-chapter review exercise 3

Cross-topic review exercise 1

4 Friction

Exercise 4A

Exercise 4B

Exercise 4C

Exercise 4D

End-of-chapter review exercise 4

5 Connected particles

Exercise 5A

Exercise 5B

Exercise 5C

End-of-chapter review exercise 5

6 General motion in a straight line

Exercise 6A

Exercise 6B

Exercise 6C

Exercise 6D

End-of-chapter review exercise 6

Cross-topic review exercise 2

7 Momentum

Exercise 7A

Exercise 7B

End-of-chapter review exercise 7

8 Work and energy

Exercise 8A

Exercise 8B

Exercise 8C

End-of-chapter review exercise 8

9 The work–energy principle and power

Exercise 9A

Exercise 9B

Exercise 9C

Exercise 9D

End-of-chapter review exercise 9

Cross-topic review exercise 3

Practice exam-style paper

How to use this resource

Welcome to your Cambridge Elevate Worked Solutions Manual

This resource contains worked solutions to the questions in the Cambridge International AS & A Level Mathematics: Mechanics Coursebook. This includes all questions in the chapter exercises, end-of-chapter review exercises, cross-topic review exercises and practice exam-style paper.

Each solution shows you step-by-step how to solve the question. You will be aware that often questions can be solved by multiple different methods. In this book, we provide a single method for each solution. Do not be disheartened if the working in a solution does not match your own working; you may not be wrong but simply using a different method. It is good practice to challenge yourself to think about the methods you are using and whether there may be alternative methods.

Additional guidance is included in **Commentary** boxes throughout the book. These boxes often clarify common misconceptions or areas of difficulty.

Many of the examples and questions you complete at this level assume constant speed or instantaneous change of speed. Neither of these are quite realistic so it is important you always question the validity of the model being used.

Some questions in the coursebook go beyond the syllabus. We have indicated these solutions with a red line to the left of the text:

E EXERCISE 3C

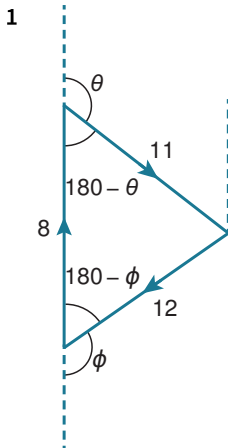

Make sure that you draw large and clear diagrams, so that all angles are clear. You may need to leave room to add more information later in each question. It is often the case, also, that you will need to extend the lines of action of forces so that you can draw the correct angles.

$$\cos(180^\circ - \phi) = \frac{8^2 + 12^2 - 11^2}{2(8)(12)} \Rightarrow \phi = 116.9^\circ$$

$$\cos(180^\circ - \theta) = \frac{11^2 + 8^2 - 12^2}{2(11)(8)} \Rightarrow \theta = 103.5^\circ$$

To navigate within the resource, select the relevant section from the Contents page and you will be taken to the page. Please note that all worked solutions available for the AS & A Level Mechanics course can be found within this digital resource. Select material can also be found within the print resource.

All worked solutions shown within this resource have been written by the authors. In examinations, the way marks are awarded may be different.

Chapter 1

Velocity and acceleration

EXERCISE 1A

1 $s = vt$
 $120 = 15v$
 $v = \frac{120}{15} = 8 \text{ m s}^{-1}$

2 $s = vt$
 $s = 9 \times 7 = 63 \text{ m}$

3 a $s = vt$
 $150 = 25t$
 $t = \frac{150}{25} = 6 \text{ s}$

b The gazelle does not move and the cheetah reaches the appropriate speed instantaneously.

Many of the examples and questions you complete at this level assume constant speed or instantaneous change of speed. Neither of these are quite realistic so it is important you always question the validity of the model being used.

4 $150 \text{ million km} = 150 \times 10^6 = 1.5 \times 10^8 \text{ km}$
 $= 1.5 \times 10^8 \times 1000 \text{ m} = 1.5 \times 10^{11} \text{ m}$

$s = vt$
 $1.5 \times 10^{11} = 3 \times 10^8 \times t$
 $t = \frac{1.5 \times 10^{11}}{3 \times 10^8} = 0.5 \times 10^3 = 5 \times 10^2 \text{ s}$
 $= 500 \text{ s} = 8 \text{ mins } 20 \text{ seconds}$

5 $s = vt$
 $1 = 1223.657 \times t$
 $t = \frac{1}{1223.657} \text{ hours}$
 $t = \frac{1}{1223.657} \times 60 \times 60 \text{ seconds}$
 $= 2.94 \text{ seconds (3 significant figures)}$

6 $s_1 = vt = 5 \times 7 = 35 \text{ m}$
 $s_2 = vt = 7 \times 13 = 91 \text{ m}$
Total distance = $35 + 91 = 126 \text{ m}$
Total time = $7 + 13 = 20 \text{ s}$

a average speed = $\frac{\text{total distance}}{\text{total time}} = \frac{126}{20} = 6.3 \text{ m s}^{-1}$

b The change of speed is instantaneous. The speed is constant for each section.

7 $s = vt$
 $s_1 = 6 \times 10 = 60 \text{ m forwards}$
 $s_2 = 3 \times 5 = 15 \text{ m backwards}$
a $s_1 - s_2 = 60 - 15 = 45 \text{ m}$

$$\text{b } \frac{\text{total displacement}}{\text{total time}} = \frac{45}{15} = 3 \text{ m s}^{-1}$$

$$\text{c } \frac{\text{total distance}}{\text{total time}} = \frac{75}{15} = 5 \text{ m s}^{-1}$$

$$8 \quad s = vt = 11 \times 5 = 55 \text{ m travelled}$$

$$\text{Total time} = 15 \text{ s}$$

$$s = vt = 12 \times 15 = 180 \text{ m}$$

$$\text{Travels } 180 - 55 = 125 \text{ m in } 10 \text{ seconds}$$

$$\text{Average speed over next 10 seconds} = \frac{125}{10} = 12.5 \text{ m s}^{-1}$$

9 Air:

$$s = vt$$

$$33 = 330t$$

$$t = \frac{33}{330} = 0.1 \text{ s}$$

Wood:

$$s = vt$$

$$33 = 3300t$$

$$t = \frac{33}{3300} = 0.01 \text{ s}$$

$$\text{Difference} = 0.1 - 0.01 = 0.09 \text{ s}$$

When you need to carry out similar calculations for two or more situations, always separate the working for each situation and label which case you are considering.

10

It is usually easier to convert minutes into seconds; speeds are rarely given in units per minute.

$$3 \text{ minutes and } 10 \text{ seconds} = 180 + 10 = 190 \text{ seconds}$$

$$\text{Time jogging} = t \text{ seconds}$$

$$\text{Time sprinting} = 190 - t \text{ seconds}$$

$$s = v_1t + v_2(190 - t)$$

$$1000 = 4t + 7(190 - t)$$

$$4t + 1330 - 7t = 1000$$

$$3t = 330$$

$$t = 110 \text{ seconds}$$

$$\text{So, time spent sprinting} = 190 - 110 = 80 \text{ s}$$

11 Distance = d

Faster:

$$s = vt$$

$$d = 45t$$

Slower:

$$s = vt$$

$$d = 44(t + 8)$$

$$45t = 44(t + 8)$$

$$45t = 44t + 352$$

$$t = 352 \text{ seconds}$$

$$d = 45 \times 352 = 15800 \text{ m}$$

Notice that we usually avoid including units until the end of a particular section of calculation. This can avoid confusion, especially when there are algebraic terms to work with.

12 First puck travels for t seconds

$$\text{Second puck travels for } t - 0.2 \text{ seconds}$$

Total distance travelled by pucks = 2 m

If one puck travels d m before the collision, the second puck must travel the remainder of the original 2 m distance, i.e. $2 - d$ m.

$$1.3t + 1.7(t - 0.2) = 2$$

$$1.3t + 1.7t - 0.34 = 2$$

$$3t = 2.34$$

$$t = 0.78 \text{ s}$$

$$s = vt = 1.3 \times 0.78 = 1.01 \text{ m}$$

13 In this question, you are asked to show that the average speeds over AC and AB are the same. It is worth noting that, if the average over AB is the same as the average over BC, then this is also the same as the average over AC.

a $t_1 = t_2 = t$

Total time = $2t$

Total distance = $s_1 + s_2$

$$\text{Average speed} = \frac{s_1 + s_2}{2t} = \frac{1}{2} \left(\frac{s_1}{t} + \frac{s_2}{t} \right) = \text{average of speeds}$$

b $s_1 = s_2 = s$

$$\text{Average speed for AC} = \frac{s + s}{t_1 + t_2} = \frac{2s}{t_1 + t_2}$$

$$\text{Average speed for AB} = \frac{s}{t_1}$$

$$\text{Equal if and only if } \frac{2s}{t_1 + t_2} = \frac{s}{t_1}$$

$$\Leftrightarrow \frac{2}{t_1 + t_2} = \frac{1}{t_1}$$

$$\Leftrightarrow t_1 + t_2 = 2t_1$$

$$\Leftrightarrow t_1 = t_2$$

The symbol \Leftrightarrow is specifically used to mean 'if and only if'. This symbol indicates that the two mathematical statements on either side of it are exactly equivalent.

14 a Right:

$$s = v_1 t_1$$

Left:

$$s = v_2 t_2$$

$$v = \frac{\text{Total distance}}{\text{Total time}} = \frac{s + s}{t_1 + t_2} = \frac{2s}{t_1 + t_2}$$

$$= \frac{2s}{\frac{s}{v_1} + \frac{s}{v_2}}$$

$$= \frac{2s}{\frac{sv_2 + sv_1}{v_1 v_2}}$$

$$= \frac{2sv_1 v_2}{sv_2 + sv_1}$$

$$= \frac{2v_1 v_2}{v_1 + v_2}$$

b If

$$\frac{2v_1 v_2}{v_1 + v_2} = 2v_1$$

then

$$\frac{v_2}{v_1 + v_2} = 1$$

$$v_2 = v_1 + v_2$$

$$v_1 = 0$$

Which would then mean that the motion never actually takes place!

Don't expect to 'spot' how to do questions like this immediately, at least not to start with. The more you experience difficult algebraic challenges, the better you will get. Initial failure should not put you off because it is all part of the learning process.

EXERCISE 1B

$$1 \quad a = \frac{v - u}{t}$$
$$a = \frac{10 - 4}{3} = 2 \text{ m s}^{-2}$$

$$2 \quad a = \frac{v - u}{t}$$
$$a = \frac{10 - 0}{4} = 2.5 \text{ m s}^{-2}$$

$$3 \quad a = \frac{v - u}{t}$$
$$6 = \frac{12 - 3}{t}$$
$$6t = 9$$
$$t = 1.5 \text{ s}$$

$$4 \quad a = \frac{v - u}{t}$$
$$3 = \frac{v - 4}{5}$$
$$15 = v - 4$$
$$v = 19 \text{ m s}^{-1}$$

Remember that the formula $a = \frac{v - u}{t}$ is the same as $v = u + at$, just rearranged.

$$5 \quad a = \frac{v - u}{t}$$
$$1.5 = \frac{9 - u}{4}$$
$$6 = 9 - u$$
$$u = 3 \text{ m s}^{-1}$$

$$6 \quad a = \frac{v - u}{t}$$
$$-2 = \frac{8 - u}{3}$$
$$-6 = 8 - u$$
$$u = 14 \text{ m s}^{-1}$$

$$7 \quad s = \frac{1}{2}(u + v)t$$

To find t using $a = (v - u)^t$:

$$0.5 = (8 - 4)^t$$

$$0.5t = 4$$

$$t = 8 \text{ s}$$

To find s :

$$= \frac{1}{2}(4 + 8) \times 8$$

$$= 48 \text{ m}$$

$$8 \quad a \quad s = \frac{1}{2}(u + v)t$$

$$60 = \frac{1}{2}(u + 9) \times 10$$

$$60 = 5u + 45$$

$$5u = 15$$

$$u = 3 \text{ m s}^{-1}$$

$$a = \frac{v - u}{t} = \frac{9 - 3}{10} = 0.6 \text{ m s}^{-2}$$

Note that the formula $s = \frac{1}{2}(u + v)t$ is the same as writing that 'distance travelled is average speed multiplied by time'.

b We assume that the sprinter has a specific position. In reality sprinters have size and shape and so are spread over a distance range at any one time. We also assume that the sprinter can keep a constant acceleration.

9 $a = \frac{v - u}{t}$

First part: $a = \frac{1 - 0}{t}$

$at = 1$ [1]

Second part: $a = \frac{5 - 1}{t + 1}$

$a(t + 1) = 4$

$at + a = 4$ [2]

Substitute [1] into [2]

$1 + a = 4$

$a = 3 \text{ m s}^{-2}$

10 $s = \frac{1}{2}(u + v)t$

$100 = \frac{1}{2}(u + v) \times 10$

$u + v = 20$ [1]

$a = \frac{v - u}{t}$

$-0.4 = \frac{v - u}{10}$

$v - u = -4$ [2]

[1] + [2]

$2v = 16$

$v = 8 \text{ m s}^{-1}$

11 If the cyclist does nothing:

$u = 10$

$s = 80$

$a = 0.1$

$v^2 = u^2 + 2as$

$v^2 = 100 + 2 \times 0.1 \times 80$

$= 116$

$v = \sqrt{116} = 10.8 \text{ m s}^{-1}$

This is a safe speed but the cyclist could pedal just a little.

EXERCISE 1C

If you find it difficult to see which equation to use, start by writing down the letters you know the values for and the letter you are trying to find. Then match these to the four variables in one of the equations.

$$\begin{aligned}1 \text{ a } \quad s &= ut + \frac{1}{2}at^2 \\ &= 2 \times 4 + \frac{1}{2} \times 3 \times 4^2 \\ &= 8 + 24 \\ &= 32 \text{ m}\end{aligned}$$

$$\begin{aligned}\text{b } \quad s &= vt - \frac{1}{2}at^2 \\ &= 17 \times 8 - \frac{1}{2} \times 2 \times 8^2 \\ &= 136 - 64 \\ &= 72 \text{ m}\end{aligned}$$

$$\begin{aligned}\text{c } \quad s &= ut + \frac{1}{2}at^2 \\ 40 &= 3 \times 5 + \frac{1}{2}a(5)^2 \\ 40 &= 15 + \frac{25}{2}a \\ \frac{25}{2}a &= 25 \\ a &= 2 \text{ m s}^{-2}\end{aligned}$$

$$\begin{aligned}\text{d } \quad s &= vt - \frac{1}{2}at^2 \\ 28 &= 13 \times 4 - \frac{1}{2}a(4)^2 \\ 28 &= 52 - 8a \\ 8a &= 24 \\ a &= 3 \text{ m s}^{-2}\end{aligned}$$

$$\begin{aligned}\text{e } \quad v^2 &= u^2 + 2as \\ 14^2 &= 2^2 + 2 \times a \times 24 \\ 196 - 4 &= 48a \\ 192 &= 48a \\ a &= 4 \text{ m s}^{-2}\end{aligned}$$

$$\begin{aligned}\text{f } \quad s &= ut + \frac{1}{2}at^2 \\ 45 &= 6u + \frac{1}{2} \times 1.5 \times 6^2 \\ 45 &= 6u + 18 \times 1.5 \\ 6u &= 45 - 27 \\ 6u &= 18 \\ u &= 3 \text{ m s}^{-1}\end{aligned}$$

$$\begin{aligned}\text{g } \quad s &= vt - \frac{1}{2}at^2 \\ 24 &= 4v - \frac{1}{2} \times -2.5 \times 4^2 \\ 24 &= 4v + 20 \\ 4v &= 4 \\ v &= 1 \text{ m s}^{-1}\end{aligned}$$

$$\begin{aligned} \text{h} \quad v^2 &= u^2 + 2as \\ 25 &= 4 + 2 \times 0.75s \\ 1.5s &= 21 \\ s &= 14 \text{ m} \end{aligned}$$

$$\begin{aligned} \text{2 a} \quad s &= ut + \frac{1}{2}at^2 \\ 24 &= 10t + \frac{1}{2} \times -2 \times t^2 \\ 24 &= 10t - t^2 \\ t^2 - 10t + 24 &= 0 \\ (t - 6)(t - 4) &= 0 \\ t &= 4, 6 \end{aligned}$$

First time is after 4 seconds

$$\begin{aligned} \text{b} \quad s &= vt - \frac{1}{2}at^2 \\ 21 &= 5t - \frac{1}{2} \times 0.5 \times t^2 \\ 21 &= 5t - \frac{1}{4}t^2 \\ 84 &= 20t - t^2 \\ t^2 - 20t + 84 &= 0 \\ (t - 14)(t - 6) &= 0 \\ t &= 6, 14 \end{aligned}$$

First time is after 6 seconds

$$\begin{aligned} \text{c} \quad s &= ut + \frac{1}{2}at^2 \\ 20 &= 3t + \frac{1}{2} \times 1 \times t^2 \\ t^2 + 6t - 40 &= 0 \\ (t + 10)(t - 4) &= 0 \\ t &= 4, -10 \\ t &> 0 \\ t &= 4 \text{ seconds} \end{aligned}$$

$$\begin{aligned} \text{3} \quad v^2 &= u^2 + 2as \\ v^2 &= 25 + 2 \times -2 \times 6 \\ v^2 &= 25 - 24 = 1 \\ v &= \pm\sqrt{1} = \pm 1 \\ \text{Initial velocity} &> 0 \\ \text{Change in direction so velocity now} &< 0 \\ v &= -1 \text{ m s}^{-1} \end{aligned}$$

$$\begin{aligned} \text{4} \quad v^2 &= u^2 + 2as \\ 169 &= u^2 + 2 \times 1 \times 60 \\ u^2 &= 169 - 120 = 49 \\ v &= \pm\sqrt{49} = \pm 7 \\ v > 0 \text{ so } u > 0 \text{ as direction not changed} \\ u &= 7 \text{ m s}^{-1} \end{aligned}$$

$$\begin{aligned} \text{5 a} \quad v^2 &= u^2 + 2as \\ v^2 &= 3^2 + 2 \times 2 \times 18 \\ &= 9 + 72 \\ &= 81 \\ v &= \pm\sqrt{81} = \pm 9 \\ v &> 0 \\ v &= 9 \text{ m s}^{-1} \end{aligned}$$

b $v > 0$ because $u > 0$ and $a > 0$

The reason for part b is to explain why $v > 0$ in part a. Whenever you start with a positive velocity and continue with a positive acceleration, you will also have a final velocity that is positive. If both u and a were negative, then v would also be negative. Things are much more complicated when u and a have different signs, because v may be positive or negative depending on how long the motion lasts. You have to think carefully about every stage of the motion to decide.

$$\begin{aligned}
 6 \quad v^2 &= u^2 + 2as \\
 0 &= 400 + 2 \times -4 \times s \\
 400 &= 8s \\
 s &= \frac{400}{8} = 50 \text{ m}
 \end{aligned}$$

$$\begin{aligned}
 7 \quad v^2 &= u^2 + 2as \\
 3600 &= 0 + 2 \times a \times 400 \\
 800a &= 3600 \\
 a &= \frac{3600}{800} = 4.5 \text{ m s}^{-2}
 \end{aligned}$$

$$\begin{aligned}
 8 \quad v^2 &= u^2 + 2as \\
 6400 &= 0 + 2 \times 4 \times s \\
 8s &= 6400 \\
 s &= 800 \text{ m}
 \end{aligned}$$

$$\begin{aligned}
 9 \quad v^2 &= u^2 + 2as \\
 0 &= 20^2 + 2 \times a \times 40 \\
 80a &= -400 \\
 a &= -5 \text{ m s}^{-2} \\
 \text{Deceleration} &= 5 \text{ m s}^{-2}
 \end{aligned}$$

Note that negative acceleration is the same as positive deceleration. It is also true that positive acceleration is negative deceleration!

$$\begin{aligned}
 10 \text{ a} \quad s &= \frac{1}{2}(u + v)t \\
 240 &= \frac{1}{2}(30 + v) \times 12 \\
 240 &= 180 + 6v \\
 6v &= 60 \\
 v &= 10 \text{ m s}^{-1}
 \end{aligned}$$

b Deceleration is constant

$$\begin{aligned}
 11 \quad v^2 &= u^2 + 2as \\
 0 &= 4.8^2 - 2 \times 0.3 s \\
 s &= \frac{4.8^2}{0.6} = 8 \times 4.8 = 38.4 \text{ m} \\
 38.4 - 38 &= 0.4 \text{ m}
 \end{aligned}$$

$$\begin{aligned}
 12 \quad v^2 &= u^2 + 2as \\
 0 &= 2.4^2 - 2 \times 0.3 \times s \\
 0.6 s &= 2.4^2 \\
 s &= 9.6 \text{ m}
 \end{aligned}$$

Stops before 10 m covered so it does not reach the hole.

13 If the car chooses to brake:

$$\begin{aligned}
 v &= u + at \\
 &= 17 - 8 \times 2 \\
 &= 1 \text{ m s}^{-1}
 \end{aligned}$$

At this rate of braking the car still has positive velocity after 2 seconds and so will overrun the lights. The car cannot brake.

If the car accelerated instead:

$$\begin{aligned}
 s &= ut + \frac{1}{2}at^2 \\
 &= 17 \times 2 + \frac{1}{2} \times 4 \times 2^2 \\
 &= 34 + 8 = 42 \text{ m}
 \end{aligned}$$

At this rate of acceleration, the car will travel 2 m past the lights at the point of changing, so it is safe to accelerate.

14 a $s = \frac{1}{2}(u + v)t$ and $v = u + at$

Replace v with $u + at$

$$\begin{aligned}
 s &= \frac{1}{2}(u + u + at)t \\
 &= \frac{1}{2}(2ut + at^2) \\
 &= ut + \frac{1}{2}at^2
 \end{aligned}$$

Although you will not usually be asked to prove these equations, it is still very sensible for you to work through how it is done. Really, this is just another example of solving simultaneous equations by substitution.

b $s = \frac{1}{2}(u + v)t$ and $v = u + at$

Rearranging the second equation $u = v - at$

$$\begin{aligned}
 s &= \frac{1}{2}(u + v)t \text{ Replace } u \text{ with } v - at \\
 &= \frac{1}{2}(v - at + v)t \\
 &= vt - \frac{1}{2}at^2
 \end{aligned}$$

Rearranging $v = u + at$:

$$t = \frac{v - u}{a}$$

Substitute into $s = \frac{1}{2}(u + v)t$

$$\begin{aligned}
 s &= \frac{1}{2}(u + v) \left(\frac{v - u}{a} \right) \\
 s &= \frac{(v + u)(v - u)}{2a} \\
 2as &= v^2 + uv - uv - u^2 \\
 v^2 &= u^2 + 2as
 \end{aligned}$$

15 Velocity at time $\frac{1}{2}t = u + a \left(\frac{1}{2}t \right) = u + \frac{1}{2}at$ [1]

But $v = u + at$

$$t = \frac{v - u}{a}$$

Substituting into [1]

$$\begin{aligned}
 \text{Velocity at time } \frac{1}{2}t &= u + \frac{1}{2}a \left(\frac{v - u}{a} \right) \\
 &= u + \frac{1}{2}(v - u) = \frac{2u + v - u}{2} = \frac{u + v}{2}
 \end{aligned}$$

16 $v^2 = u^2 + 2as$ [1]

$$\left(\text{speed at distance } \frac{1}{2}s \right)^2 = u^2 + 2a \left(\frac{1}{2}s \right) = u^2 + as$$
 [2]

[1] gives

$$\begin{aligned}
 v^2 - u^2 &= 2as \\
 as &= \frac{v^2 - u^2}{2}
 \end{aligned}$$

Substitute into [2]

$$\left(\text{speed at distance } \frac{1}{2}s\right)^2 = u^2 + \frac{v^2 - u^2}{2} = \frac{2u^2 + v^2 - u^2}{2} = \frac{u^2 + v^2}{2}$$

$$\text{speed at distance } \frac{1}{2}s = \sqrt{\frac{u^2 + v^2}{2}}$$

Half the distance happens after half the time because the object is slower in the first part of the motion and faster in the second part.

Speed at half the distance happens after speed at half the time, therefore, and so must be larger.

But speed at half the time is the mean of the initial and final speeds.

So speed at half the distance is greater than the mean of the initial and final speeds.

EXERCISE 1D

1

When sketching displacement–time graphs, it is essential that you label the axes correctly and include the units. You don't need to draw the graphs accurately, but you should try to show them roughly to scale and include all the key values.

a $s = vt = 3 \times 10 = 30 \text{ m}$

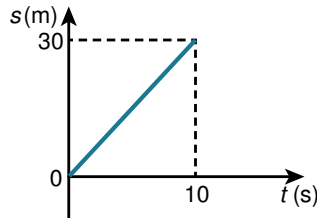

b $t = \frac{s}{v} = \frac{30}{1.5} = 20 \text{ s}$

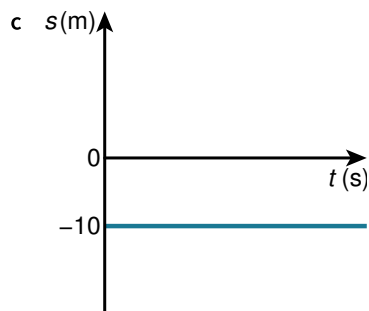
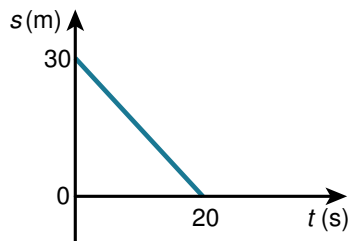

d First part:

$$t = \frac{s}{v} = \frac{300}{10} = 30 \text{ s}$$

Second part:

$$t = \frac{s}{v} = \frac{200}{10} = 20 \text{ s}$$

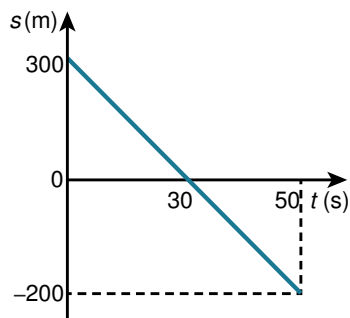

2 a $s = ut + \frac{1}{2}at^2$
 $= 0 + \frac{1}{2} \times 4 \times 10^2 = 200 \text{ m}$

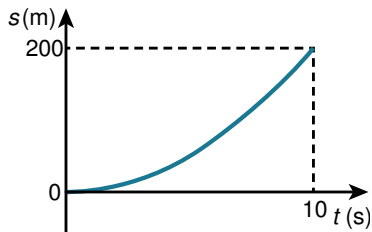

b $v = u + at$

Remember that when an object rises vertically, it stops instantaneously before it starts to fall.

Speed is zero at maximum point

$$0 = 5 - 10t$$

$$t = 0.5$$

$$s = ut + \frac{1}{2}at^2$$

$$= 5 \times 0.5 + 0.5 \times -10 \times 0.5^2 = 1.25$$

$$\text{Height} = 1 + 1.25 = 2.25 \text{ m}$$

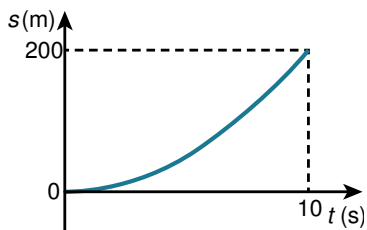

c At the lowest point:

$$v = u + at$$

$$0 = -10 + 2t$$

$$t = 5s$$

$$s = ut + \frac{1}{2}at^2$$

$$= -10 \times 5 + \frac{1}{2} \times 2 \times 5^2$$

$$= -50 + 25 = -25$$

$$100 - 25 = 75 \text{ m above the ground}$$

At 175 m:

$$s = ut + \frac{1}{2}at^2$$

$$75 = -10t + \frac{1}{2} \times 2 \times t^2$$

$$t^2 - 10t - 75 = 0$$

$$(t - 15)(t + 5) = 0$$

$$t = -5, 15$$

$$t > 0$$

$$t = 15$$

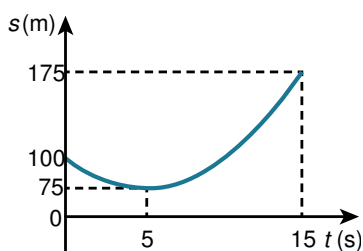

Although we have presented the graph at the end of the calculation, you should draw the graph as you go along. Always start by sketching the overall shape. This will show you the main values that you need to

calculate, such as minimum points, total distances at certain times, etc.

d Highest point:

$$v = u + at$$

$$0 = 5 - 10t$$

$$t = 0.5$$

$$s = ut + \frac{1}{2}at^2$$

$$= 5 \times \frac{1}{2} - \frac{1}{2} \times 10 \times 0.5^2$$

$$= 1.25 \text{ m}$$

At sea level:

$$s = ut + \frac{1}{2}at^2$$

$$-18.75 = 5t - \frac{1}{2} \times 10 \times t^2$$

$$5t^2 - 5t - 18.75 = 0$$

$$t = \frac{-(-5) \pm \sqrt{(-5)^2 - 4 \times 5 \times -18.75}}{2 \times 5}$$

$$= -1.5 \text{ or } 2.5$$

$$t > 0$$

$$t = 2.5 \text{ s}$$

Level with top of cliff:

$$s = ut + \frac{1}{2}at^2$$

$$0 = 5t - \frac{1}{2} \times 10 \times t^2$$

$$5 = 5t$$

$$t = 1 \text{ s}$$

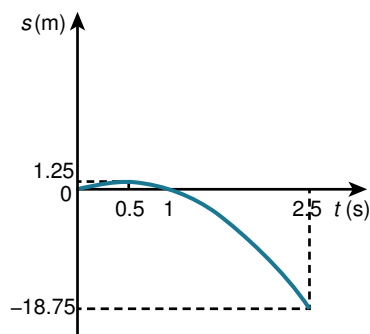

3 a

In this question note that the speed at the end of the first stage (v in the first equation) becomes the speed at the start of the second stage (u in the second part).

After 5 seconds:

$$s = ut + \frac{1}{2}at^2$$

$$= 0 + 0.5 \times 3 \times 5^2$$

$$= 37.5$$

$$v = u + at$$

$$= 0 + 3 \times 5$$

$$= 15 \text{ ms}^{-1}$$

After 15 seconds:

$$s = ut + \frac{1}{2}at^2$$

$$= 15 \times 10 + 0$$

$$= 150 \text{ m}$$

$$37.5 + 150 = 187.5$$

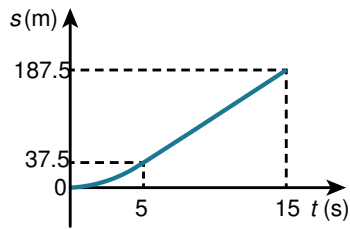

b At 6 seconds:

$$s = ut + \frac{1}{2}at^2$$

$$= 10 \times 6 + 0$$

$$= 60 \text{ m}$$

When it comes to rest:

$$v = u + at$$

$$0 = 10 - 2t$$

$$t = 5 \text{ s}$$

$$6 + 5 = 11 \text{ s}$$

$$s = ut + \frac{1}{2}at^2$$

$$= 10 \times 5 + \frac{1}{2} \times -2 \times 5^2$$

$$= 50 - 25 = 25 \text{ m}$$

$$60 + 25 = 85 \text{ m}$$

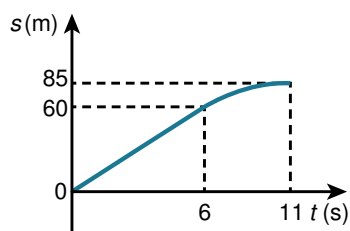

c At 20 m away:

$$s = ut + \frac{1}{2}at^2$$

$$40 = 8t$$

$$t = 5 \text{ s}$$

At the lights:

$$s = ut + \frac{1}{2}at^2$$

$$20 = 8t + \frac{1}{2} \times 2 \times t^2$$

$$t^2 + 8t - 20 = 0$$

$$(t + 10)(t - 2) = 0$$

$$t = 2, -10$$

$$t > 0 \text{ so } t = 2$$

$$5 + 2 = 7$$

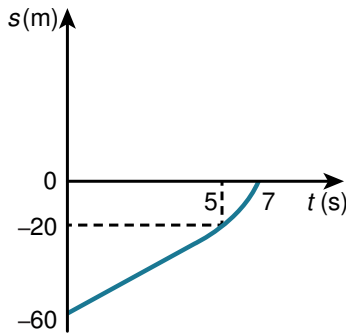

Remember that the traffic lights are at distance 0, so this is why the positive distances become negative displacements on the graph. We calculated the distance that remained to be covered, but on the graph we show the position (or displacement) in relation to the traffic lights.

d Accelerating stage:

$$v = u + at$$

$$6 = 0 + 1.5t$$

$$t = 4\text{s}$$

$$s = ut + \frac{1}{2}at^2$$

$$= 0 + \frac{1}{2} \times 1.5 \times 4^2$$

$$= 12\text{ m}$$

$$-100 + 12 = -88$$

Constant speed:

$$50 - (-88) = 138$$

$$s = ut + \frac{1}{2}at^2$$

$$138 = 6t + 0$$

$$t = 23$$

$$4 + 23 = 27\text{ s}$$

Decelerating stage:

$$v = u + at$$

$$0 = 6 - t$$

$$t = 6$$

$$27 + 6 = 33\text{ s}$$

$$s = ut + \frac{1}{2}at^2$$

$$= 6 \times 6 - \frac{1}{2} \times 1 \times 6^2 = 18\text{ m}$$

$$18 + 50 = 68\text{ m}$$

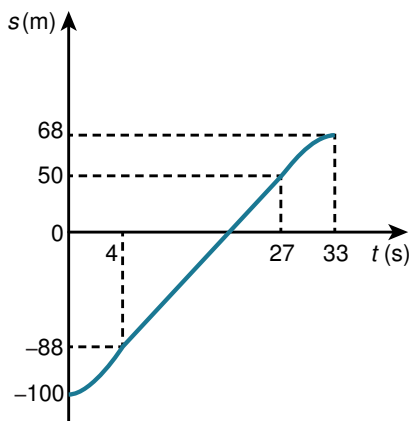

You should not worry if your sketches seem to be out of scale, as long as the correct shape is clear, with specific points labelled correctly.

$$4 \text{ Gradient} = \frac{100 - (-60)}{10} = 16$$

$$s = 16t - 60$$

When front of train reaches the entrance:

$$0 = 16t - 60$$

$$16t = 60$$

$$t = 3.75 \text{ s}$$

$$5 \text{ a } s = p(t - q)^2 + r$$

Stationary at $t = 10$ so maximum at $t = 10$

$$(t - q)^2 = 0 \text{ at } t = 10$$

$$10 - q = 0$$

$$q = 10$$

At the same point

$$s = 0$$

$$0 = 0 + r$$

$$r = 0$$

$$t = 0 \text{ gives } s = -50$$

$$-50 = p(0 - 10)^2 + 0$$

$$-50 = 100p$$

$$p = -0.5$$

$$\begin{aligned} \text{b } s &= -0.5(t - 10)^2 + 0 \\ &= -0.5(t^2 - 20t + 100) \\ &= -0.5t^2 + 10t - 50 \\ &= -50 + 10t - 0.5t^2 \\ &= s_0 + ut + \frac{1}{2}at^2 \end{aligned}$$

$$u = 10 \text{ and } \frac{1}{2}a = -\frac{1}{2}$$

$$a = -1$$

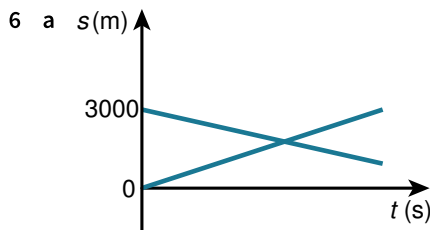

b 1st car: 2nd car:

$$s = ut + \frac{1}{2}at^2$$

$$= 30t + 0$$

$$s = 30t$$

$$s = s_0 + ut + \frac{1}{2}at^2$$

$$= 3000 - 20t + 0$$

You only need to include the s_0 in the formula $s = s_0 + ut + \frac{1}{2}at^2$ if the object you are considering is not initially placed at the point from which s is measured. You can also work out the equations of the lines using the gradient and intercept.

$$\text{c } 30t = 3000 - 20t$$

$$50t = 3000$$

$$t = 60 \text{ s}$$

$$s = 30t$$

$$= 30 \times 60 = 1800 \text{ m from junction 1}$$

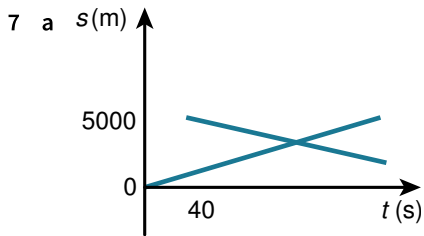

b Northbound train: $s = 25t$

Southbound train:

$$\begin{aligned} s &= 5000 - 15(t - 40) \\ &= 5000 - 15t + 600 \\ &= 5600 - 15t \end{aligned}$$

Trains pass when

$$25t = 5600 - 15t$$

$$40t = 5600$$

$$t = \frac{5600}{40} = 140 \text{ s}$$

$$s = 25 \times 140 = 3500 \text{ m}$$

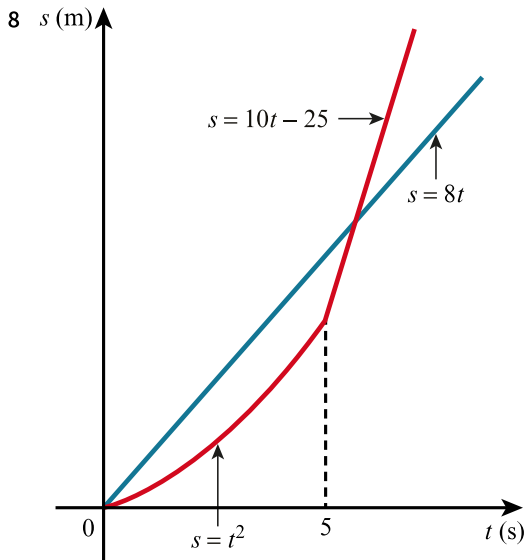

Cyclist 2: $s = 8t$ [1]

Cyclist 1: $s = 0t + \frac{1}{2} \times 2 \times t^2 = t^2$

$t = 5$ gives $s = 25$ m

Straight line section starts at (5, 25) and has gradient $5 \times 2 = 10 \text{ m s}^{-1}$

$$s = 10t + c$$

$$25 = 50 + c$$

$$c = -25$$

$$s = 10t - 25$$
 [2]

Equating [1] and [2]

$$8t = 10t - 25$$

$$2t = 25$$

$$t = 12.5 \text{ s}$$

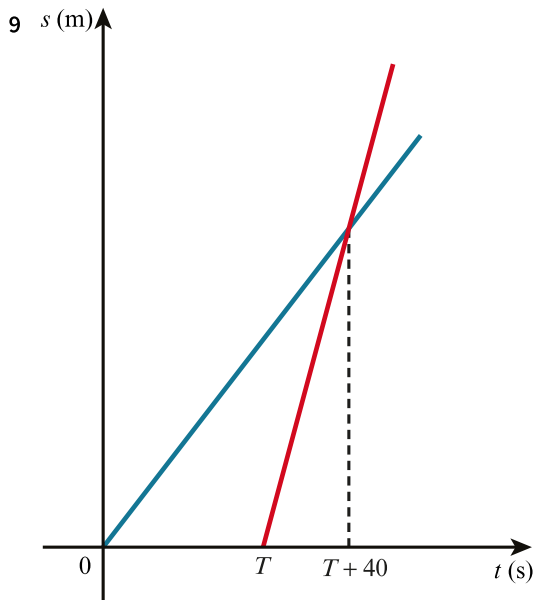

a First boat: $s = 3.2t$

Second boat: $s = 4t + c$

$s = 0$ at $t = T$

$$0 = 4T + c$$

$$c = -4T$$

$$s = 4t - 4T$$

Boats meet at $t = T + 40$:

$$3.2(T + 40) = 4(T + 40) - 4T$$

$$3.2T + 128 = 4T + 160 - 4T$$

$$3.2T = 32$$

$$T = 10$$

First boat finishes when:

$$3.2t = 2000$$

$$t = 625 \text{ s}$$

Second boat:

$$s = 4t - 40$$

$$2000 = 4t - 40$$

$$4t = 2040$$

$$t = 510 \text{ s}$$

$$\text{Difference} = 625 - 510 = 115 \text{ s}$$

b Constant speed is maintained throughout the various oar strokes. This isn't true in reality because the boat tends to surge forward more quickly as the crew pulls on their oars.

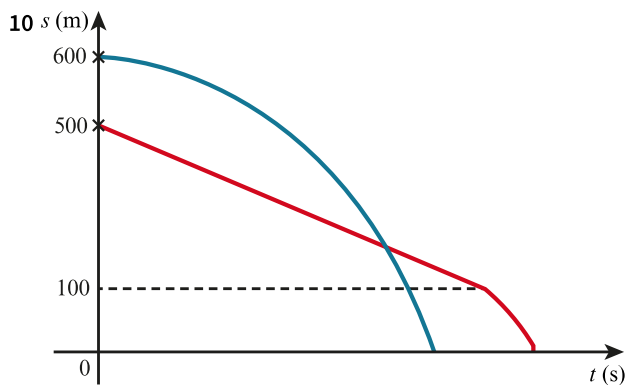

First runner:

First part: 400 m at 4 m s^{-1} . This takes $\frac{400}{4} = 100 \text{ s}$

Second part, until the end of the race:

$$s = ut + \frac{1}{2}at^2$$

$$100 = 4t + \frac{1}{2} \times 0.1 \times t^2$$

$$2000 = 80t + t^2$$

$$t^2 + 80t - 2000 = 0$$

$$(t + 100)(t - 20) = 0$$

$$t = 20 \text{ or } -100$$

$$t > 0$$

$$t = 20 \text{ s for the final section}$$

Usually time is positive, because it is zero at the start of measurement. Negative time can have meaning, but it is not generally necessary to use it.

Total time to finish for the first runner is $20 + 100 = 120 \text{ s}$

Second runner:

Assume finishes at exactly the same time.

$$s = ut + \frac{1}{2}at^2$$

$$600 = 3.8 \times 120 + \frac{1}{2} \times a \times 120^2$$

$$600 = 3.8 \times 120 + 7200a$$

$$600 = 456 + 7200a$$

$$7200a = 144$$

$$a = 0.02 \text{ m s}^{-2}$$

So, $a > 0.02 \text{ m s}^{-2}$ means the second runner will finish before the first runner.

11 Acceleration time = $\frac{20}{4} = 5 \text{ s}$

$$v^2 = u^2 + 2as$$

$$20^2 = 0 + 2 \times 4s$$

$$s = 50 \text{ m}$$

Van takes 50 metres to accelerate. In this time the car in front travels $5 \times 20 = 100 \text{ m}$. So the van will be 50 m behind the car in front. Car behind needs a further 10 m behind the van and so the gap between the cars is $50 + 10 = 60 \text{ m}$.

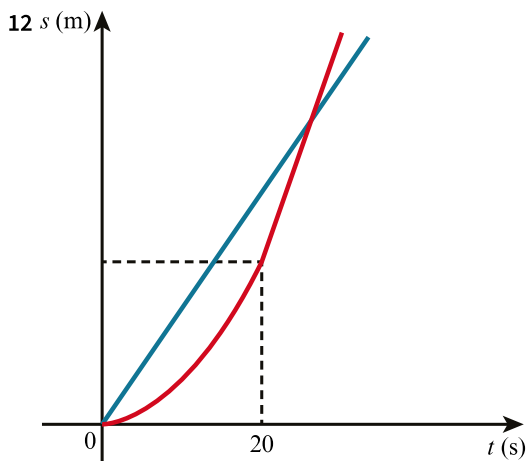

Motorcycle acceleration time = $\frac{50}{2.5} = 20 \text{ s}$

Distances travelled:

Car: $s = vt = 20 \times 40 = 800 \text{ m}$

Motorcycle:

$$v^2 = u^2 + 2as$$

$$50^2 = 0 + 2 \times 2.5s$$

$$5s = 2500$$

$$s = 500 \text{ m} < 800 \text{ m}$$

Not caught car yet.

Equations of straight Lines and the intersections of the lines:

Car:

$$s = 40t$$

Motorcycle:

$$s = 50t + c$$

$$\text{At } t = 20, s = 500$$

$$500 = 50 \times 20 + c$$

$$500 = 1000 + c$$

$$c = -500$$

$$s = 50t - 500$$

Meet when

$$50t - 500 = 40t$$

$$10t = 500$$

$$t = 50 \text{ s}$$

- 13** Assume that the direction out to sea is positive. The wave and boy both have negative velocities and the acceleration of the wave is positive.

Wave position at time t :

$$s = s_0 + ut + \frac{1}{2}at^2$$

$$s = 30 - 11.6t + \frac{1}{2} \times 1.6t^2 = 30 - 11.6t + 0.8t^2$$

Boy position at time t :

$$s = -2t$$

Distance between the two = position of wave - position of the boy

$$= 30 - 11.6t + 0.8t^2 - (-2t)$$

$$= 0.8t^2 - 9.6t + 30$$

$$= 0.8(t^2 - 12t + 37.5)$$

$$= 0.8 \left\{ (t - 6)^2 - 36 + 37.5 \right\}$$

$$= 0.8(t - 6)^2 + 1.5 \times 0.8$$

$$= 0.8(t - 6)^2 + 1.2$$

Minimum distance occurs after 6 seconds and is 1.2 m.

- 14** Time for slower swimmer:

$$u = 1$$

$$s = ut + \frac{1}{2}at^2$$

Time for the first stage is t

$$20 = t + \frac{1}{2} \times 0.8 \times t^2$$

Multiply through by 5

$$2t^2 + 5t - 100 = 0$$

$$t = \frac{-5 \pm \sqrt{5^2 - 4 \times 2 \times -100}}{4}$$

Positive solution is $t = 5.9307$

Speed at the start of the second stage

$$v^2 = u^2 + 2as$$

$$v = \sqrt{1^2 + 2 \times 0.8 \times 20} = \sqrt{33}$$

Time for the second stage:

$$s = ut + \frac{1}{2}at^2$$

$$10 = \sqrt{33}t + \frac{1}{2}t^2$$

$$t^2 + 2\sqrt{33}t - 20 = 0$$

Quadratic formula gives a positive solution of

$$t = 1.5355$$

Total time for slower swimmer is $1.5355 + 5.9307 = 7.4662$ s

In this question it is helpful to think of the 'worst case scenario': where a slower swimmer is caught up by a faster one. The 'gain' by the second swimmer reduces the gap between arrivals at the end of the ride. Look, then, at the difference in time between the fastest and slowest and add the 5 seconds required.

Time for faster swimmer:

$$u = 2$$

$$s = ut + \frac{1}{2}at^2$$

Time for first stage is t

$$20 = 2t + \frac{1}{2} \times 0.8 \times t^2$$

$$2t^2 + 10t - 100 = 0$$

$$t^2 + 5t - 50 = 0$$

$$(t + 10)(t - 5) = 0$$

Positive solution is $t = 5$

Speed at the start of the second stage:

$$v^2 = u^2 + 2as$$

$$v = \sqrt{2^2 + 2 \times 0.8 \times 20} = \sqrt{36} = 6$$

Time for the second stage:

$$s = ut + \frac{1}{2}at^2$$

$$10 = 6t + \frac{1}{2}t^2$$

$$t^2 + 12t - 20 = 0$$

Quadratic formula gives a positive solution of $t = 1.4833$

Total time for slower swimmer is $1.4833 + 5 = 6.4833$ s

Difference between faster and slower times = 0.9829

Need to leave 5 seconds and allow for this additional catch up time.

Leave $5 + 0.9829$ seconds, i.e. minimum whole number of seconds = **6**

15

$$s = ut + \frac{1}{2}at^2$$

$$h = ut - \frac{1}{2}gt^2$$

$$gt^2 - 2ut + 2h = 0$$

$$t = \frac{-(-2u) \pm \sqrt{(-2u)^2 - 4g(2h)}}{2g}$$

$$t_1 = \frac{2u - \sqrt{4u^2 - 8gh}}{2g}$$

$$t_2 = \frac{2u + \sqrt{4u^2 - 8gh}}{2g}$$

$$t_1 + t_2 = \frac{2u - \sqrt{4u^2 - 8gh} + 2u + \sqrt{4u^2 - 8gh}}{2g}$$

$$= \frac{4u}{2g} = \frac{2u}{g}$$

$$u = \frac{g(t_1 + t_2)}{2}$$

$$t_2 - t_1 = \frac{2u + \sqrt{4u^2 - 8gh} - (2u - \sqrt{4u^2 - 8gh})}{2g}$$

$$= \frac{2\sqrt{4u^2 - 8gh}}{2g}$$

$$= \frac{2\sqrt{4}\sqrt{u^2 - 2gh}}{2g}$$

$$= \frac{4\sqrt{u^2 - 2gh}}{2g}$$

$$= \frac{2\sqrt{u^2 - 2gh}}{g}$$

Note that near to the end of this calculation we pull out a factor of root 4. When taking the square root of an expression, taking out any square factors will help you to simplify things in this way.

We now have

$$t_2 - t_1 = \frac{2\sqrt{u^2 - 2gh}}{g}$$

$$g(t_2 - t_1) = 2\sqrt{u^2 - 2gh}$$

$$\sqrt{u^2 - 2gh} = \frac{g(t_2 - t_1)}{2}$$

$$u^2 - 2gh = \frac{g^2(t_2 - t_1)^2}{4}$$

But

$$u^2 = \frac{g^2(t_1 + t_2)^2}{4}$$

$$\frac{g^2(t_1 + t_2)^2}{4} - 2gh = \frac{g^2(t_2 - t_1)^2}{4}$$

$$8gh = g^2(t_1 + t_2)^2 - g^2(t_2 - t_1)^2$$

$$= g^2(t_1^2 + t_2^2 + 2t_1t_2 - t_2^2 - t_1^2 + 2t_2t_1)$$

$$8gh = 4g^2t_1t_2$$

$$h = \frac{4g^2t_1t_2}{8g} = \frac{gt_1t_2}{2}$$

EXERCISE 1E

1 a $v(\text{m s}^{-1})$

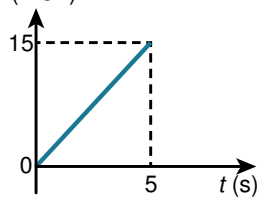

$$\begin{aligned}v &= u + at \\ &= 0 + 3 \times 5 = 15 \text{ m s}^{-1}\end{aligned}$$

b $v = u + at$

$$= 2 + 0.5 \times 6 = 5 \text{ m s}^{-1}$$

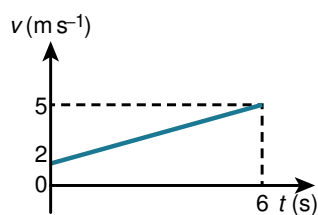

c $v(\text{m s}^{-1})$

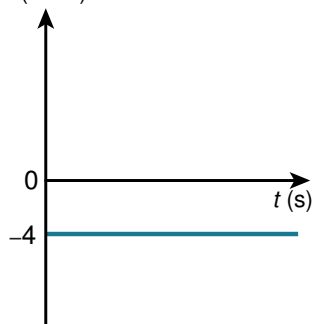

Note that the direction chosen is now negative. It is important to remember the difference between 'speed', which does not require a specified direction, and 'velocity', which does.

d $v = u + at$

$$0 = 6 - 0.3t$$

$$t = \frac{6}{0.3} = 20 \text{ s}$$

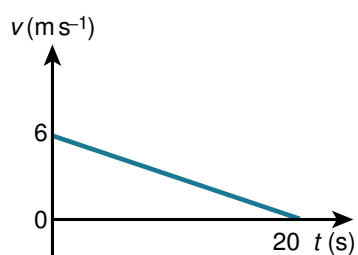

2 a $v = u + at$

$$0 = 20 - 10t$$

$$10t = 20$$

$$t = 2 \text{ s}$$

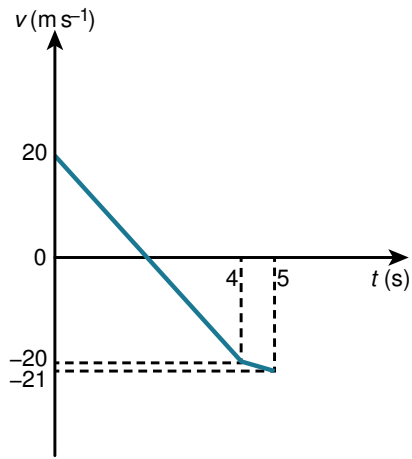

Note that the reduction in acceleration is shown as a shallower gradient.

b $v = u + at$
 $= 0 - 10 \times 0.5 = -5 \text{ m s}^{-1}$

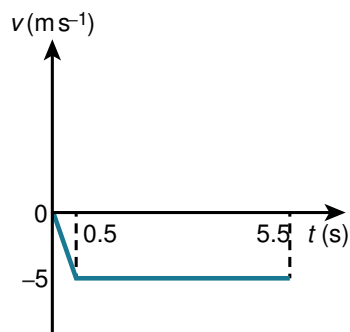

c $v = u + at$
 $= 0 - 5 \times 6 = -30 \text{ m s}^{-1}$

$v = u + at$
 $0 = -30 + 2t$
 $2t = 30$
 $t = 15$

$6 + 15 = 21$

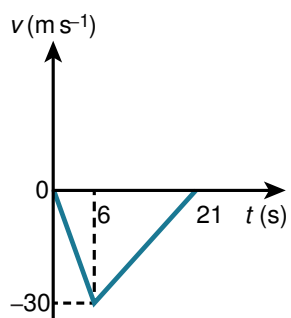

d $v = u + at$
 $= 0 + 5 \times 7 = 35 \text{ m s}^{-1}$

$v = u + at$
 $0 = 35 - 10t$
 $10t = 35$
 $t = 3.5 \text{ s}$

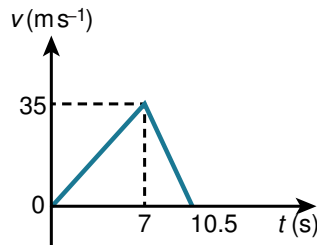

- 3 When a velocity-time problem involves a combination of constant accelerations and constant velocities, the graphs will often include triangles and/or trapezia. It is good to remember that the area of a trapezium, with two parallel sides of lengths a and b , separated by a distance h is given by $A = \left(\frac{a+b}{2}\right)h$. It is often possible to use rectangles and triangles only, but this often complicates the working because you need to work in multiple stages.

Distance travelled = area under the graph

$$\begin{aligned} &= \left(\frac{10 + 30}{2}\right) \times 8 \\ &= 20 \times 8 \\ &= 160 \text{ m} \end{aligned}$$

4 Acceleration = $-\frac{10}{1} = -10$

Hits the ground T seconds after falling from the highest point

$$v = u + at$$

$$-15 = 0 - 10T$$

$$-\frac{15}{T} = -10$$

$$T = 1.5 \text{ s}$$

$$\text{Total flight time} = 1.5 + 1 = 2.5$$

Remember that areas below the time axis are negative, so you need to calculate areas above and below the axis separately.

$$\text{Area A} = \frac{1}{2} \times 1 \times 10 = 5 \text{ m}$$

$$\text{Area B} = \frac{1}{2} \times 1.5 \times 15 = 11.25 \text{ m}$$

$$\begin{aligned} \text{Height of initial project} &= \text{difference between these two distances} \\ &= 11.25 - 5 = 6.25 \text{ m} \end{aligned}$$

5 Area = $\left(\frac{10+6}{2}\right) \times 12$
 $= 16 \times 6$
 $= 96 \text{ m}$

6 Area = $\left(\frac{300 + (120 - 60)}{2}\right) \times 7$
 $= \frac{360}{2} \times 7$
 $= 1260 \text{ m}$

7 First section:

$$\begin{aligned} v &= u + at \\ &= 0 + 5 \times 10 \\ &= 50 \text{ m s}^{-1} \end{aligned}$$

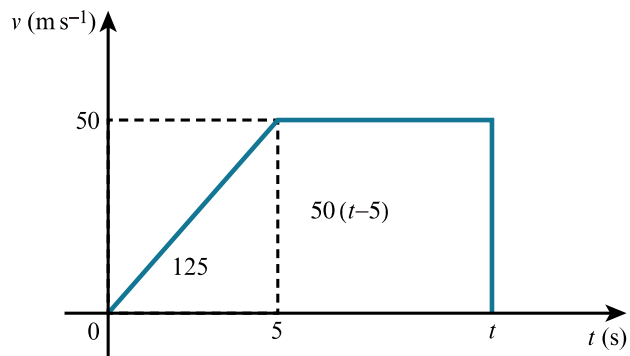

$$\text{Area} = \frac{1}{2} \times 5 \times 50 + 50 \times (t - 5)$$

$$= 125 + 50(t - 5)$$

$$1000 = 125 + 50(t - 5)$$

$$50(t - 5) = 875$$

$$t - 5 = \frac{875}{50}$$

$$t = 5 + \frac{875}{50} = 22.5 \text{ s}$$

8 First part:

$$v = u + at$$

$$= 0 + 0.4 \times 5 = 2 \text{ m s}^{-1}$$

Last part:

$$v = u + at$$

$$0 = 2 - 0.8t$$

$$0.8t = 2$$

$$t = 2.5 \text{ s}$$

If you need to calculate specific lengths of time, use a letter other than t for the time. Even T will be fine.

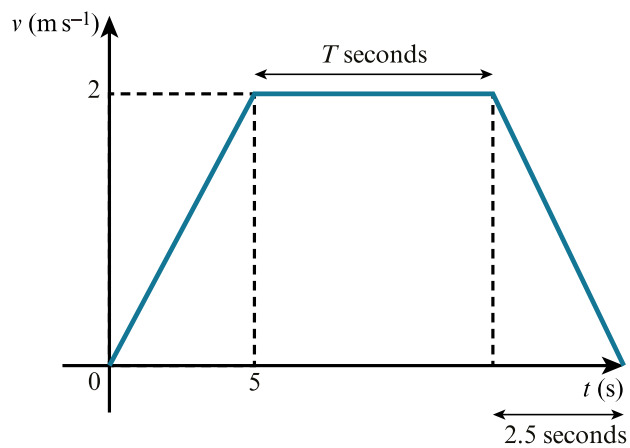

Area of trapezium = 30

$$\left(\frac{T + (T + 5 + 2.5)}{2} \right) \times 2 = 30$$

$$2T + 7.5 = 30$$

$$2T = 22.5$$

$$T = 11.25 \text{ s}$$

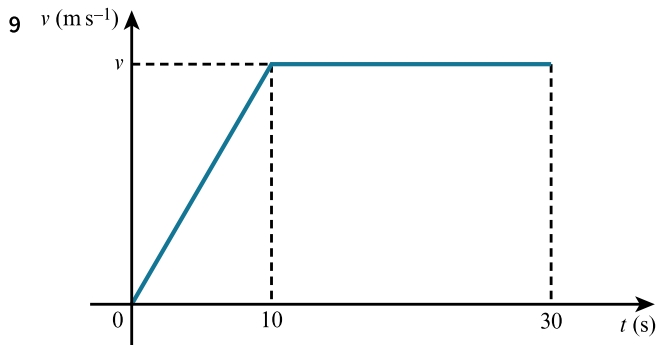

$$\left(\frac{20 + 30}{2}\right) \times v = 300$$

$$50v = 600$$

$$v = 12$$

10 a

$$v = u + at$$

$$v = 0 + 0.2t$$

$$t = \frac{v}{0.2}$$

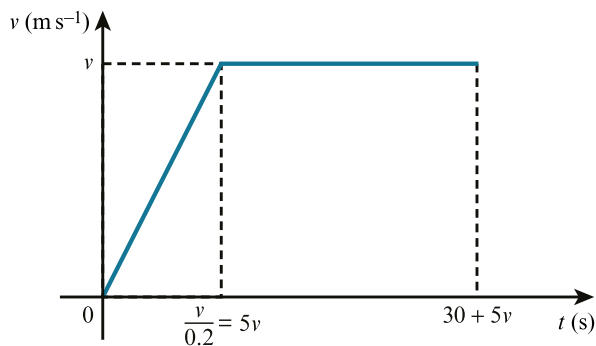

$$\left(\frac{30 + 30 + 5v}{2}\right) \times v = 400$$

$$(60 + 5v)v = 800$$

$$5v^2 + 60v = 800$$

$$v^2 + 12v - 160 = 0$$

$$(v - 8)(v + 20) = 0$$

$$v = 8, -20$$

$$v > 0$$

$$v = 8$$

b The acceleration of the boat is constant. There is an instantaneous change when the boat moves to constant speed.

11 The maximum height will be reached when the velocity of the block reaches zero.

When accelerating:

$$0 = v - 10t$$

$$t = \frac{v}{10}$$

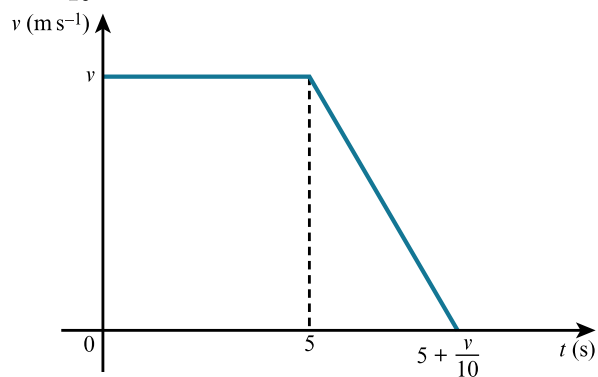

$$\left(\frac{5 + (5 + \frac{v}{10})}{2} \right) v = 6$$

$$\left(10 + \frac{v}{10} \right) v = 12$$

$$(100 + v)v = 120$$

$$v^2 + 100v - 120 = 0$$

$$v = \frac{-100 \pm \sqrt{100^2 - 4 \times 1 \times -120}}{2}$$

$$v = -101.19 \text{ or } 1.19$$

$$v > 0$$

$$v = 1.19$$

12 First, complete a velocity time graph:

Initial acceleration of the car:

$$\begin{aligned} v &= u + at \\ &= 0 + 5 \times 4 = 20 \text{ m s}^{-1} \end{aligned}$$

Truck deceleration:

$$\begin{aligned} v &= u + at \\ 0 &= 22 - t \\ t &= 22 \text{ s} \end{aligned}$$

$$22 + 10 = 32 \text{ s}$$

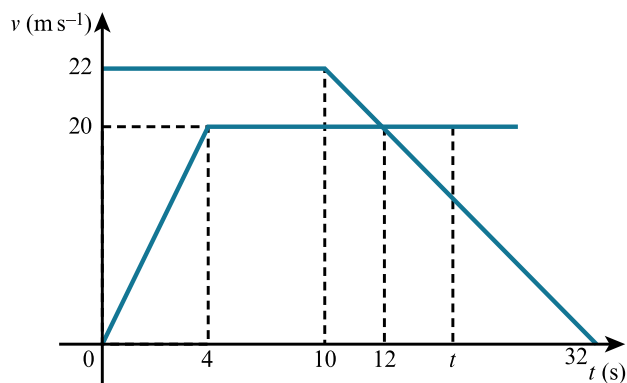

a Velocities will be equal when the truck reduces velocity to 20 m s^{-1} .

$$\begin{aligned} v &= u + at \\ 20 &= 22 - t \\ t &= 2 \text{ s} \end{aligned}$$

$$10 + 2 = 12 \text{ s}$$

Greatest distance occurs when the velocities are equal. Before that the truck is faster and the distance is still increasing. After that the car catches up.

After 12 s:

Distance travelled by:

$$car = \left(\frac{8 + 12}{2} \right) \times 20 = 200 \text{ m}$$

$$\begin{aligned} truck &= 22 \times 10 + \left(\frac{22 + 20}{2} \right) \times 2 \\ &= 220 + 42 = 262 \text{ m} \end{aligned}$$

$$\text{Difference} = 262 - 200 = 62 \text{ m}$$

Note that this calculation required a combination of a rectangle and a trapezium for the truck.

b At time t we find the area under each graph.

Car:

$$\begin{aligned}\text{Area} &= \frac{1}{2} \times 4 \times 20 + 20(t - 4) \\ &= 40 + 20(t - 4)\end{aligned}$$

Truck:

The answer given shows that the area has been calculated by considering three shapes, as shown in the diagram here.

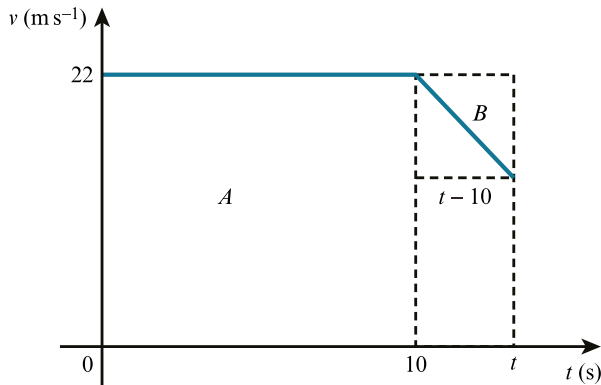

Area of rectangle A + (Area of the largest dotted rectangle – Area of triangle B)

$$\begin{aligned}&= 22 \times 10 + 22(t - 10) - \frac{1}{2}(t - 10)(t - 10) \\ &= 220 + 22(t - 10) - \frac{1}{2}(t - 10)^2\end{aligned}$$

Car and truck pass when these two distances are equal

$$220 + 22(t - 10) - \frac{1}{2}(t - 10)^2 = 40 + 20(t - 4)$$

$$220 + 22t - 220 - \frac{1}{2}(t^2 - 20t + 100) = 40 + 20t - 80$$

$$22t - \frac{1}{2}t^2 + 10t - 50 = 20t - 40$$

$$\frac{1}{2}t^2 - 12t + 10 = 0$$

$$t^2 - 24t + 20 = 0$$

$$t = \frac{-(-24) \pm \sqrt{(-24)^2 - 4 \times 1 \times 20}}{2}$$

$$t = 0.864 \text{ or } 23.1$$

$$t > 10$$

$$t = 23.1\text{s}$$

13 Bradley's deceleration time:

$$v = u + at$$

$$0 = 15 - 0.5t$$

$$0.5t = 15$$

$$t = 30\text{ s}$$

$$50 + 30 = 80\text{ s}$$

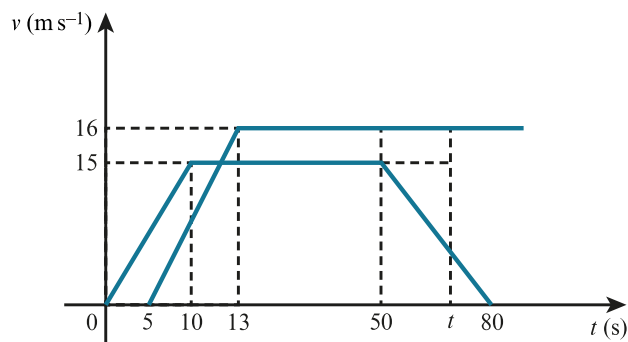

a At the point of slowing, distance travelled by both:

Bradley:

$$= \left(\frac{50 + 40}{2} \right) \times 15 = 45 \times 15 = 675 \text{ m}$$

Chris:

$$= \left(\frac{45 + 37}{2} \right) \times 16 = 41 \times 16 = 656 \text{ m}$$

Bradley has travelled $675 - 656 = 19 \text{ m}$ further, but was 50 m ahead to start with. He is still 69 m ahead.

b Overtakes after time t

Distances travelled by:

Bradley:

$$= 725 + \frac{1}{2}(t - 50)[15 + (15 - 0.5(t - 50))]$$

$$= 725 + \frac{1}{2}(t - 50)(55 - 0.5t)$$

$$= 725 + \frac{1}{2}(55t - 0.5t^2 - 2750 + 25t)$$

$$= 725 + \frac{1}{2}(80t - 0.5t^2 - 2750)$$

$$= -0.25t^2 + 40t - 650$$

Chris:

$$= 656 + 16(t - 50)$$

$$= 16t - 144$$

Meet when

$$-0.25t^2 + 40t - 650 = 16t - 144$$

$$0.25t^2 - 24t + 506 = 0$$

$$t^2 - 96t + 2024 = 0$$

$$t = \frac{96 \pm \sqrt{96^2 - 4 \times 1 \times 2024}}{2}$$

$$= \frac{96 \pm \sqrt{1120}}{2}$$

$$t = 31.3 \text{ or } t = 64.7$$

Since $t > 50$, Bradley has been cycling 64.7 s when Chris overtakes him.

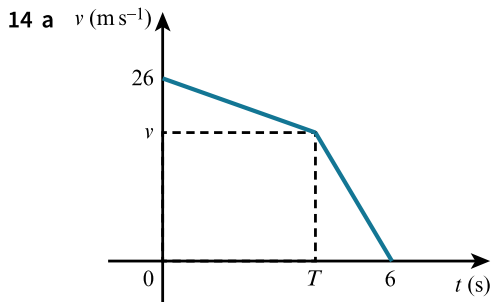

b Section 1:

$$\text{Gradient} = -3$$

$$v - \text{intercept} = 26$$

$$v = 26 - 3t$$

Section 2:

$$\text{Gradient} = -5$$

$$v = -5t + c$$

$$v = 0 \text{ when } t = 6$$

$$0 = -30 + c$$

$$c = 30$$

$$v = 30 - 5t$$

c Breaking occurs at the intersection of the two line segments.

$$26 - 3t = 30 - 5t$$

$$2t = 4$$

$$t = 2 \text{ s}$$

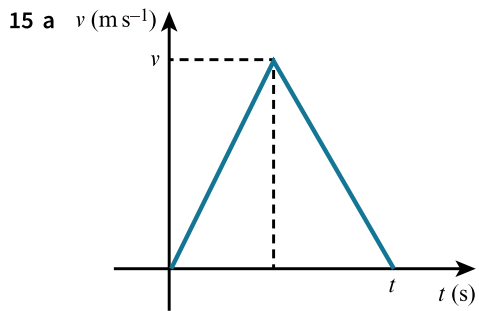

The diagram is a triangle with base length t and height v .

Distance travelled = area of triangle = $\frac{1}{2}tv$ and this does not depend on either acceleration or deceleration.

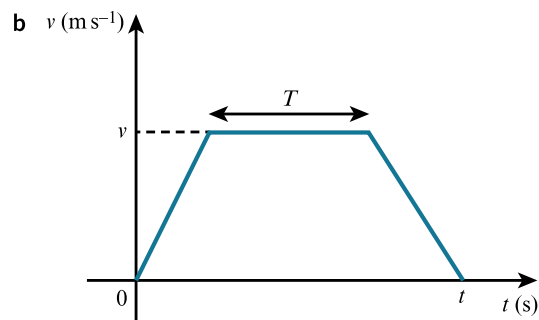

The diagram is a trapezium with parallel sides of length T and t .

Distance travelled = area of trapezium = $\left(\frac{t+T}{2}\right)v$ and this does not depend on either acceleration or deceleration.

EXERCISE 1F

Many of the distance time (and speed time) graphs that you encounter at this level are drawn with sudden changes in gradient, using straight lines and so on. None of these things quite represents reality, so it's important that you always question the validity of the model being used.

- 1 Travels 20 m at 10 m s^{-1}

$$s = vt$$

$$20 = 10t$$

$$t = 2 \text{ s}$$

Travels 40 m at 8 m s^{-1}

$$s = vt$$

$$40 = 8t$$

$$t = 5 \text{ s}$$

Note that velocity–time graphs can have discontinuities, but distance–time graphs cannot. If the latter were possible, the object in question would need to jump from one place to another in zero seconds. Discontinuities in velocity–time graphs show up as sudden changes in gradient in distance–time graphs.

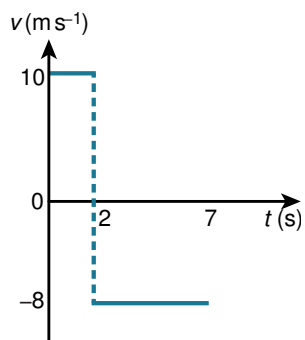

During the return, reaches the point of projection, 20 m from the goal when

$$s = 0$$

$$s = vt$$

$$20 = 8t$$

$$t = 2.5 \text{ s}$$

$$2 + 2.5 = 4.5 \text{ s}$$

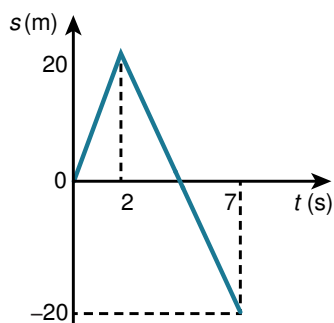

- 2 In the first 2.5 seconds:

$$v = u + at$$

$$= 8 - 0.8 \times 2.5$$

$$= 6 \text{ m s}^{-1}$$

In the final part of the motion:

$$v = u + at$$

$$0 = 2 - 0.8t$$

$$0.8t = 2$$

$$t = \frac{2}{0.8} = 2.5 \text{ s}$$

$$2.5 + 2.5 = 5 \text{ s}$$

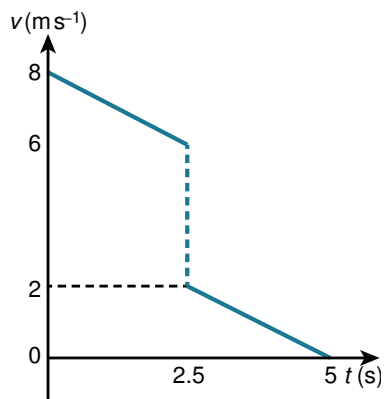

Distance travelled in first 2.5 s:

$$s = ut + \frac{1}{2}at^2$$

$$= 8 \times 2.5 + \frac{1}{2} \times -0.8 \times 2.5^2$$

$$= 17.5 \text{ m}$$

Distance travelled between 2.5 s and 5 s:

$$s = ut + \frac{1}{2}at^2$$

$$= 2 \times 2.5 - \frac{1}{2} \times 0.8 \times 2.5^2$$

$$= 2.5 \text{ m}$$

$$\text{Total} = 17.5 + 2.5 = 20 \text{ m}$$

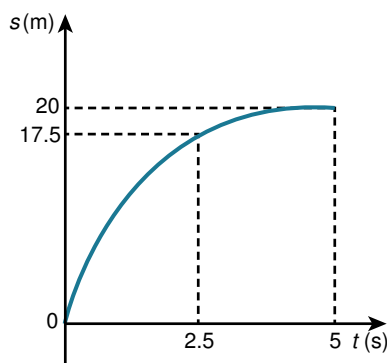

3 Journey to batsman:

$$s = vt$$

$$20 = 4t$$

$$t = 5 \text{ s}$$

Journey back:

$$v = u + at$$

$$0 = -6 + 0.5t$$

$$t = \frac{6}{0.5} = 12 \text{ s}$$

$$5 + 12 = 17 \text{ s}$$

When there are sudden changes in the gradient of distance-time graphs it is very important that you show this clearly. Make sure that your diagram is large enough to make it obvious.

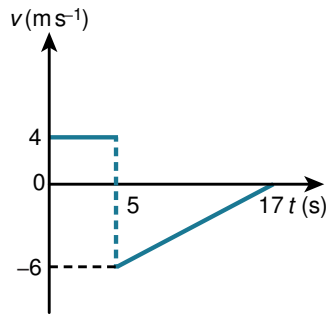

Area of triangle in velocity-time graph is the distance travelled between 5 and 17 seconds

$$= \frac{1}{2} \times 12 \times 6 = 36 \text{ m}$$

$$20 - 36 = -16 \text{ m}$$

Ball crosses its starting point when it has travelled 20 m in other direction

$$s = ut + \frac{1}{2}at^2$$

$$-20 = -6t + \frac{1}{2} \times 0.5 \times t^2$$

$$-20 = -6t + \frac{1}{4}t^2$$

$$t^2 - 24t + 80 = 0$$

$$(t - 4)(t - 20) = 0$$

$$t = 4 \text{ and } t = 20$$

It crosses the starting point is 4 s after being hit, i.e. $t = 9$

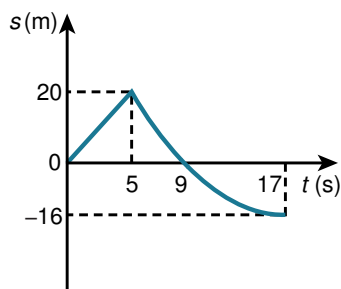

4 First part:

$$v^2 = u^2 + 2as$$

$$v^2 = 0^2 + 2 \times 10 \times 20 = 400$$

$$v = \pm 20$$

$$v < 0$$

$$v = -20$$

$$v = u + at$$

$$-20 = 0 - 10t$$

$$t = 2 \text{ s}$$

Second part:

$$v = u + at$$

$$0 = 10 - 10t$$

$$t = 1 \text{ s}$$

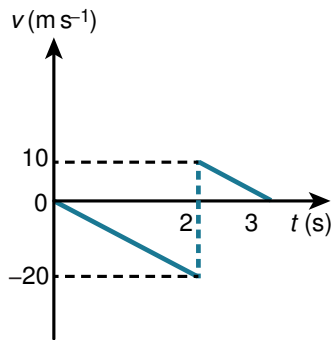

Area under second triangle in the velocity – time diagram = height to which the ball bounces

$$= \frac{1}{2} \times 1 \times 10$$

$$= 5 \text{ m}$$

Always check, very carefully, that you have taken into account direction, whether positive or negative. A velocity–time graph can jump between the regions above and below the time axis suddenly, but a distance–time graph always needs to cross the t -axis if displacements change between positive and negative.

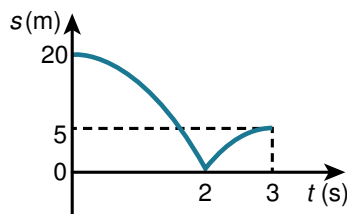

5 First part:

$$v^2 = u^2 + 2as$$

$$v^2 = (-2.25)^2 - 2 \times 0.2 \times 5$$

$$= 3.0625$$

$$v = \pm 1.75$$

$$v < 0$$

$$v = -1.75$$

Time to wall:

$$v = u + at$$

$$-1.75 = -2.25 + 0.2t$$

$$0.2t = 0.5$$

$$t = 2.5 \text{ s}$$

Speed after bounce:

$$1.75 \times 0.8 = 1.4$$

Time to stop:

$$v = u + at$$

$$0 = 1.4 - 0.2t$$

$$t = 7 \text{ s}$$

$$2.5 + 7 = 9.5 \text{ s}$$

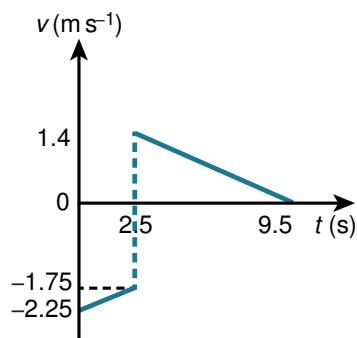

Distance travelled in the second part = area of second triangle in velocity – time graph

$$= \frac{1}{2} \times 7 \times 1.4 = 4.9 \text{ m}$$

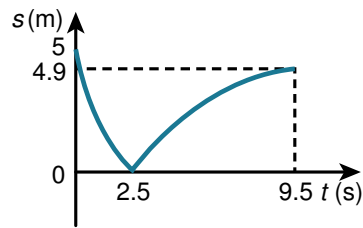

6 a Journey to first impact:

$$v^2 = u^2 + 2as$$

$$v^2 = 3.1^2 - 2 \times 0.2 \times 3$$

$$v = \sqrt{3.1^2 - 2 \times 0.2 \times 3} = 2.9 \text{ m s}^{-1}$$

Time taken:

$$2.9 = 3.1 - 0.2t$$

$$0.2t = 0.2$$

$$t = 1 \text{ s}$$

Journey to second impact at the other end of the table:

$$v^2 = u^2 + 2as$$

$$u = 0.7 \times -2.9 = -2.03 \text{ (negative because of change of direction)}$$

$$v^2 = (-2.03)^2 - 2 \times 0.2 \times 6$$

$$v = -\sqrt{(-2.03)^2 - 2 \times 0.2 \times 6} = -1.31(18308) \text{ m s}^{-1}$$

Time taken:

$$-1.3118308 = -2.03 + 0.2t$$

$$0.2t = 0.718169$$

$$t = 3.59 \text{ s}$$

Final slow down:

Initial speed

$$= 0.7 \times 1.3118308 = 0.918 \text{ (another change of direction)}$$

$$v = u + at$$

$$0 = 0.918 - 0.2t$$

$$0.2t = 0.918$$

$$t = 4.59 \text{ s}$$

Final distance:

$$s = ut + \frac{1}{2}at^2$$

$$= 0.918 \times 4.59 - 0.5 \times 0.2 \times 4.59^2$$

$$= 2.11 \text{ m}$$

$3 - 2.11 = 0.89 \text{ m}$ from the centre

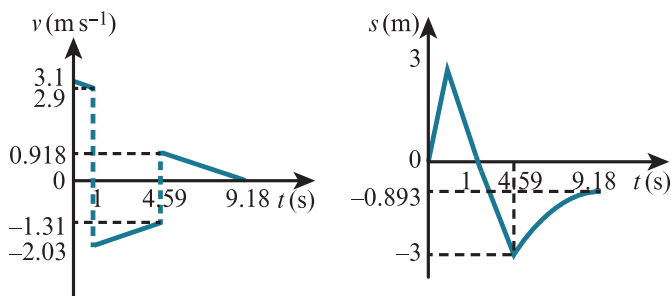

b The ball is modelled as a particle and so has no 'size'. Also, the change in velocity is instantaneous.

7 Let u_n be the speed before hitting the ground at bounce n .

$$v_n = \frac{u_n}{2}$$

$u_1 = 20$, $t_1 = 2$ from the first drop, so $v_1 = 10$.

From any particular bounce, $u_{n+1} = v_n$ using $v^2 = u^2 + 2as$,

$$\text{so } v_{n+1} = \frac{v_n}{2}$$

so $v_n = \frac{20}{2^n}$ because this is a geometric series.

Using $s = ut + \frac{1}{2}at^2$, $0 = v_n T_n - 5T_n^2$ where $T_n = t_{n+1} - t_n$ gives

$$T_n = t_{n+1} - t_n = \frac{v_n}{5} = \frac{4}{2^n} \text{ and } t_n = 2 + \frac{2\left(1 - \frac{1}{2}^{n-1}\right)}{1 - \frac{1}{2}} = 6 - 8 \times \left(\frac{1}{2}\right)^n$$

from the sum of the time before the first bounce and the sum of a geometric series (T_n) between bounces.

Now, $15 - 2.5t_n = 15 - 2.5\left(6 - 8 \times \left(\frac{1}{2}\right)^n\right) = \frac{20}{2^n} = v_n$ as required.

END-OF-CHAPTER REVIEW EXERCISE 1

1 a $v^2 = u^2 + 2as$
 $0 = 10^2 + 2 \times -2s$
 $4s = 100$
 $s = 25 \text{ m}$

b After 3 seconds

$$v = u + at$$

$$= 0 + 2 \times 3 = 6 \text{ m s}^{-1}$$

Distance covered

$$s = ut + \frac{1}{2}at^2$$

$$= 0 + \frac{1}{2} \times 2 \times 3^2 = 9 \text{ m}$$

$$\text{Remaining distance} = 25 - 9 = 16 \text{ m}$$

$$s = vt$$

$$16 = 6t$$

$$t = 2.67 \text{ s}$$

$$\text{Total} = 3 + 2.67 = 5.67 \text{ s}$$

An alternative approach to this distance calculation is to use the speed found just beforehand. There is always a risk that this might be incorrect, so it is better to use only values given in the question where possible.

2 a $v = u + at$
 $30 = 15 + 3t$
 $3t = 15$
 $t = 5 \text{ s}$

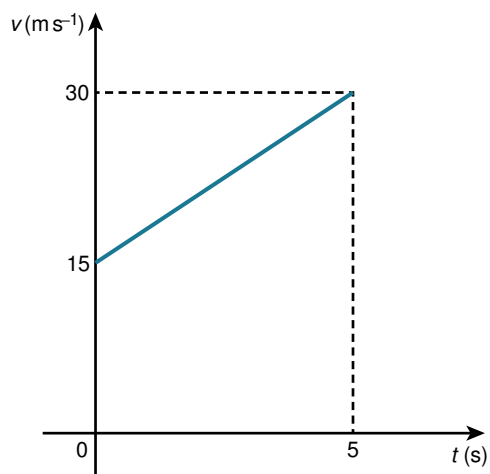

$$\text{Distance} = \text{Area under graph} = \left(\frac{15 + 30}{2} \right) \times 5$$

$$= \frac{225}{2} = 112.5 \text{ m}$$

b During the final part of the motion

$$v = u + at$$

$$0 = 30 - 5t$$

$$5t = 30$$

$$t = 6 \text{ s}$$

Now draw the speed-time graph and use the fact that the area must be 600.

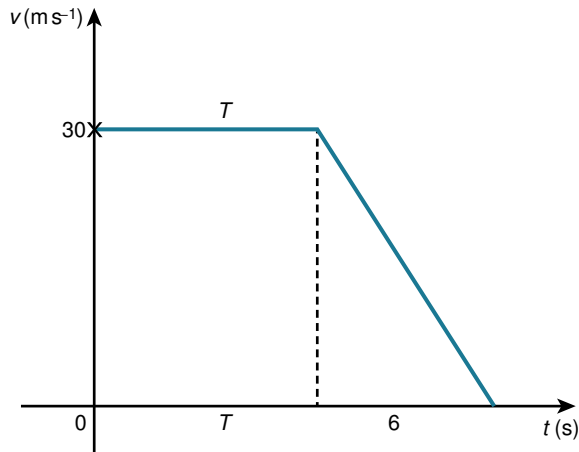

$$\left(\frac{T + T + 6}{2}\right) \times 30 = 600$$

$$\left(\frac{2T + 6}{2}\right) \times 30 = 600$$

$$T + 3 = 20$$

$$T = 17 \text{ s}$$

$$17 + 6 = 23 \text{ s}$$

- 3 a Assume that the lead runner does not accelerate.

Time to finish:

$$s = vt$$

$$200 = 4t$$

$$t = 50 \text{ s}$$

Assume that the chaser also finishes in 50 seconds

$$s = ut + \frac{1}{2}at^2$$

$$260 = 5 \times 50 + \frac{1}{2}a \times 50^2$$

$$\frac{1}{2}a \times 2500 = 260 - 250 = 10$$

$$a = \frac{10 \times 2}{2500} = 0.008 \text{ m s}^{-2}$$

Any acceleration exceeding this value will allow the chaser to catch the lead runner.

- b Find the lead runner's finishing time, assuming that there is now an acceleration of 0.05 m s^{-2} :

$$s = ut + \frac{1}{2}at^2$$

$$200 = 4t + \frac{1}{2} \times 0.05 \times t^2$$

$$8000 = 160t + t^2 \text{ (Multiply by 40)}$$

$$t^2 + 160t - 8000 = 0$$

$$(t + 200)(t - 40) = 0$$

$$t = 40 \text{ or } -200$$

$$t > 0 \text{ so } t = 40 \text{ s}$$

If the chaser catches the lead runner after exactly 40 s:

$$s = ut + \frac{1}{2}at^2$$

$$260 = 5 \times 40 + \frac{1}{2}a \times 40^2$$

$$520 = 400 + 1600a$$

$$1600a = 120$$

$$a = \frac{120}{1600} = 0.075 \text{ m s}^{-2}$$

Any acceleration greater than this will allow the chaser to catch the lead runner before the end of the race.

$$\begin{aligned}
 4 \text{ a } \quad v^2 &= u^2 + 2as \\
 0 &= 100^2 + 2a \times 800 \\
 1600a &= -10000 \\
 a &= -6.25 \text{ m s}^{-2} \\
 d &= 6.25 \text{ m s}^{-2}
 \end{aligned}$$

$$\begin{aligned}
 \text{b } \quad v^2 &= u^2 + 2as \\
 v^2 &= 100^2 + 2 \times 50 \times -6.25 = 9375
 \end{aligned}$$

v is the speed at which the plane travels when it meets the hook. For the next part of the motion $u^2 = 9375$ because the speed at the end of the first part is the speed at the start of the next.

$$\begin{aligned}
 0 &= 9375 + 2a \times 100 \\
 200a &= -9375 \\
 a &= -46.9 \text{ m s}^{-2} \\
 d &= 46.9 \text{ m s}^{-2}
 \end{aligned}$$

Both the first and second parts of this calculation use the square of the speed. This means you do not need to find the square root of 9375 as a decimal, because you already know the answer when you square it again!

$$\begin{aligned}
 5 \quad v &= u + at \\
 18 &= 0 + 6a \\
 a &= 3 \text{ m s}^{-2} \\
 s &= ut + \frac{1}{2}at^2 \\
 &= 0 + \frac{3}{2}t^2
 \end{aligned}$$

$$\text{At } t = 6, s = \frac{3}{2} \times 6^2 = 54 \text{ m}$$

Acceleration in second part, which takes $15 - 6 = 9$ seconds

$$\begin{aligned}
 v &= u + at \\
 0 &= 18 + 9a \\
 a &= -2 \text{ m s}^{-2} \\
 s &= s_0 + ut + \frac{1}{2}at^2 \\
 &= 54 + 18t - \frac{1}{2} \times 2 \times t^2 \\
 &= 54 + 18t - t^2
 \end{aligned}$$

This part of the graph is the shape of a negative quadratic.

$$\text{Total distance} = 54 + 18 \times 9 - 9^2 = 135 \text{ m}$$

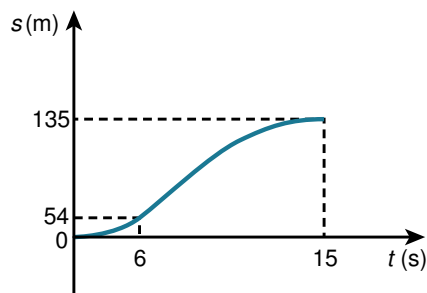

$$6 \text{ Area under the graph} = 350$$

$$\begin{aligned}
 \frac{1}{2} \times 10 \times 2v + \left(\frac{2v + v}{2} \right) \times 40 &= 350 \\
 10v + 3v \times 20 &= 350 \\
 70v &= 350 \\
 v &= 5 \text{ m s}^{-1}
 \end{aligned}$$

7 a In this question you will see that the calculation needs to be divided into two sections. The sudden change of direction of the ball means that the acceleration is not constant. This is why it is not possible to complete all of the calculations in one go.

Time and speed at which the ball hits the wall:

$$s = ut + \frac{1}{2}at^2$$

$$10 = 4t - 0.25t^2$$

$$t^2 - 16t + 40 = 0$$

$$t = \frac{-(-16) \pm \sqrt{(-16)^2 - 4 \times 1 \times 40}}{2 \times 1}$$
$$= 8 \pm 2\sqrt{6}$$

$$\text{First time} = 8 - 2\sqrt{6} \text{ s}$$

$$v = u + at = 4 - 0.5(8 - 2\sqrt{6})$$
$$= 4 - 4 + \sqrt{6} = \sqrt{6} \text{ m s}^{-1}$$

During this motion the footballer walks towards the wall

$$s = vt$$
$$= 2(8 - 2\sqrt{6})$$
$$= 16 - 4\sqrt{6}$$

The distance between the ball and the footballer is

$$10 - (16 - 4\sqrt{6}) = 4\sqrt{6} - 6 \text{ m}$$

If the time taken for the ball to return to the footballer after rebounding is t_2 seconds

Distance moved by the footballer + distance moved by the ball = $4\sqrt{6} - 6$

$$2t_2 + \sqrt{6}t_2 - \frac{1}{2} \times 0.5t_2^2 = 4\sqrt{6} - 6$$

$$(2 + \sqrt{6})t_2 - 0.25t_2^2 = 4\sqrt{6} - 6$$

$$t_2^2 - 4(2 + \sqrt{6})t_2 + 16\sqrt{6} - 24 = 0$$

Quadratic formula gives

$$t_2 = 0.89898\dots \text{ or } 16.898\dots$$

First returns to the footballer when $t_2 = 0.89898\dots$

$$\text{Total time} = t_2 + 8 - 2\sqrt{6} = 4.00 \text{ s}$$

- b** The assumption is that the ball starts to move at 4 m s^{-1} instantly after kicked. i.e. No acceleration time. It is assumed, also, that no time is taken when the ball bounces from the wall.

- 8 a** Let the length of the course be d m

Time taken for the car to move the length of the course:

$$s = ut + \frac{1}{2}at^2$$

$$d = 0 + \frac{1}{2} \times 2t^2 = t^2$$

$$t = \sqrt{d}$$

Time taken for the sound to move the length of the course

$$s = vt$$

$$d = 340t$$

$$t = \frac{d}{340}$$

Total time is 12 s

$$\sqrt{d} + \frac{d}{340} = 12$$

$$d + 340\sqrt{d} - 4080 = 0$$

$$(\sqrt{d})^2 + 340\sqrt{d} - 4080 = 0$$

$$\sqrt{d} = \frac{-340 \pm \sqrt{340^2 - 4 \times 1 \times -4080}}{2 \times 1}$$

$$\sqrt{d} = 11.603\dots \text{ or } -351.60\dots$$

\sqrt{d} is positive

$$\sqrt{d} = 11.603\dots$$

$$d = (\sqrt{d})^2 = 135 \text{ m (3 s.f.)}$$

b $t = \sqrt{d} = 11.6\text{s}$

- 9 a** Taking the starting point of the lion as the point from which all distances are measured:

Lion:

After 5 seconds the lion travels at $3 \times 5 = 15 \text{ m s}^{-1}$

$$\begin{aligned} \text{After 8 s: } s &= 0 \times 5 + \frac{1}{2} \times 3 \times 5^2 + 15 \times 3 \\ &= 82.5 \text{ m} \end{aligned}$$

Zebra:

$$s = 0 \times 7 + \frac{1}{2} \times 2 \times 7^2 + 35 = 84 \text{ m} > 82.5 \text{ m}$$

After 8 seconds the zebra is still 1.5 m ahead.

- b** Distances, from the same starting point, after $t > 8$ seconds:

Lion:

$$\begin{aligned} s &= 0 \times 5 + \frac{1}{2} \times 3 \times 5^2 + 3 \times 15 + 15(t - 8) - \frac{1}{2} \times \frac{1}{2} \times (t - 8)^2 \\ &= \frac{75}{2} + 45 + 15t - 120 - \frac{1}{4}(t^2 - 16t + 64) \\ &= -\frac{1}{4}t^2 + 19t - \frac{107}{2} \end{aligned}$$

Zebra:

$$\begin{aligned} s &= 0 \times 7 + \frac{1}{2} \times 2 \times 7^2 + 35 + 2 \times 7(t - 8) \\ &= -28 + 14t \end{aligned}$$

Distance between the zebra and the lion:

$$\begin{aligned} &-28 + 14t - \left(-\frac{1}{4}t^2 + 19t - \frac{107}{2} \right) \\ &= \frac{1}{4}t^2 - 5t + \frac{51}{2} \\ &\frac{1}{4}t^2 - 5t + \frac{51}{2} \\ &= \frac{1}{4}(t^2 - 20t) + \frac{51}{2} \\ &= \frac{1}{4}\left\{ (t - 10)^2 - 100 \right\} + \frac{51}{2} \\ &= \frac{1}{4}(t - 10)^2 - 25 + 25.5 \\ &= \frac{1}{4}(t - 10)^2 + 0.5 \end{aligned}$$

This has minimum value 0.5 m when $t = 10$ seconds.

- 10 a** Distance between = Car distance – Tractor distance – Safe distance

$$\begin{aligned} &= 15t + \frac{1}{2} \times 2 \times t^2 - 15t - 20 \\ &= t^2 - 20 \end{aligned}$$

Car hits the speed limit when $v = 25$

$$v = u + at$$

$$25 = 15 + 2t$$

$$2t = 10$$

$$t = 5 \text{ s}$$

After 5 s

Distance between = $t^2 - 20 = 5^2 - 20 = 5 \text{ m} < 20 \text{ m}$ so still not at a safe distance.

- b** When the car reaches the speed limit the difference between the speeds of the two vehicles is maintained at $25 - 15 = 10 \text{ m s}^{-1}$

The distance between the vehicles needs to increase by 15 m at this speed.

$$\frac{15}{10} = 1.5 \text{ seconds to get to the safe distance.}$$

Total time = 1.5 + 5 = 6.5 seconds.

- c Safe distance for the car coming the other way = distance travelled by the overtaking car + distance covered by the approaching car + 20 m safe distance.

$$= 15 \times 5 + \frac{1}{2} \times 2 \times 5^2 + 1.5 \times 25 + 20 + 6.5 \times 25 = 320 \text{ m}$$

11 $s = s_0 + ut + \frac{1}{2}at^2$

Position of first player's ball after t seconds:

Take the direction away from P1 as positive.

$$s = 0 + 6t - \frac{1}{2} \times 0.1 \times t^2$$

Position of second player's ball after t seconds:

$$s = 90 - 4t + \frac{1}{2} \times 0.1 \times t^2$$

Meet when

$$6t - \frac{1}{2} \times 0.1 \times t^2 = 90 - 4t + \frac{1}{2} \times 0.1 \times t^2$$

$$10t - 0.1t^2 = 90$$

$$t^2 - 100t + 900 = 0$$

$$(t - 90)(t - 10) = 0$$

$$t = 10 \text{ or } 90$$

$t = 10$ is the time at which the first meeting happens

$$s = 6 \times 10 - \frac{1}{2} \times 0.1 \times 10^2 = 60 - 5 = 55 \text{ m}$$

12 First t seconds

$$\text{Distance} = \frac{1}{2} \times t \times 2v = vt = 80$$

$$\begin{aligned} \text{Total distance} &= \frac{1}{2} \times t \times 2v + \left(\frac{2v+v}{2}\right) \times 4t + \frac{1}{2} \times v \times 2t \\ &= vt + 6vt + vt = 8vt = 8 \times 80 = 640 \text{ m} \end{aligned}$$

13 The question assumes that the fly is travelling faster than either train.

Together, the fly and the southbound train must travel a total distance of d m.

Using $s = vt$:

t_1 is the time taken for the fly to meet the southbound train.

$$wt_1 + vt_1 = d$$

$$t_1(w + v) = d$$

$$t_1 = \frac{d}{w + v}$$

$$\text{Distance travelled by the fly in this time} = wt_1 = \frac{wd}{w + v}$$

$$\text{Distance travelled by northbound train in this time} = ut_1 = \frac{ud}{w + v}$$

Distance between northbound train and fly after t_1 seconds

$$= \frac{wd}{w + v} - \frac{ud}{w + v} = \frac{d(w - u)}{w + v}$$

= distance to be covered in the second part of the journey.

Using $s = vt$:

t_2 is the time taken for the fly to meet the northbound train.

$$wt_2 + ut_2 = \frac{d(w-u)}{w+v}$$

$$t_2(w+u) = \frac{d(w-u)}{w+v}$$

$$t_2 = \frac{d(w-u)}{(w+v)(w+u)}$$

$$\begin{aligned} \text{Total time} = t_1 + t_2 &= \frac{d}{(w+v)} + \frac{d(w-u)}{(w+v)(w+u)} \\ &= \frac{d(w+u)}{(w+v)(w+u)} + \frac{d(w-u)}{(w+v)(w+u)} = \frac{dw + du + dw - du}{(w+v)(w+u)} \\ &= \frac{2dw}{(w+v)(w+u)} \end{aligned}$$

Northbound train travels at $u \text{ m s}^{-1}$ for this time.

Distance travelled by northbound train = total time \times speed

$$= \frac{2dw}{(w+v)(w+u)} \times u = \frac{2uwd}{(w+v)(w+u)}$$

14 a Measure distances from the starting point of the second car.

Distance of the first car from this point at time t

$$= s + vt - \frac{1}{2}at^2$$

Distance of second car from starting point at time t

$$= ut - \frac{1}{2}at^2$$

Second car overtakes when

$$s + vt - \frac{1}{2}at^2 = ut - \frac{1}{2}at^2$$

$$s + vt = ut$$

$$s = ut - vt$$

$$s = t(u - v)$$

$$t = \frac{s}{u - v}$$

b Distance travelled by the second car

$$= ut - \frac{1}{2}at^2$$

$$= u \left(\frac{s}{u-v} \right) - \frac{1}{2}a \left(\frac{s}{u-v} \right)^2$$

$$= \frac{us}{u-v} - \frac{as^2}{2(u-v)^2}$$

$$= \frac{2us(u-v)}{2(u-v)^2} - \frac{as^2}{2(u-v)^2}$$

$$= \frac{2u^2s - 2uvs - as^2}{2(u-v)^2}$$

15 i First part

$$\frac{\text{Change in speed}}{\text{time}} = \frac{2.1 - 1.5}{30} = 0.02 \text{ m s}^{-2}$$

Second part

$$\frac{\text{Change in speed}}{\text{time}} = \frac{0 - 2.1}{10} = -0.21 \text{ m s}^{-2}$$

$$\text{ii } \left(\frac{1.5 + 2.1}{2} \right) \times 30 + \frac{1}{2} \times 10 \times 2.1 - \frac{1}{2} \times 20 \times 2.2$$

$$= 54 + 10.5 - 22$$

$$= 42.5 \text{ m}$$

Notice that velocity is negative after 40 seconds, so the woman has changed direction. This means she must have walked past B and then returned to B.

iii $54 + 10.5 + 22 = 86.5 \text{ m}$

This time the question is asking for the total distance walked, whatever the direction. Even though the woman has to change direction to return to B, she still adds to her total distance to get there.

16 i $v(\text{ms}^{-1})$

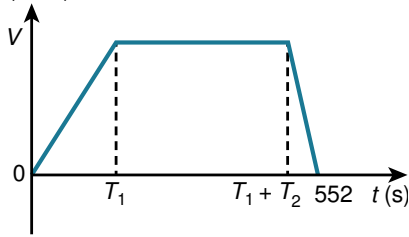

$$v = u + at$$

$$V = 0 + 0.3T_1$$

$$T_1 = \frac{V}{0.3} = \frac{10V}{3}$$

$$0 = V - 1 \times T_3$$

$$T_3 = V$$

ii Total distance

$$\begin{aligned} &= \frac{1}{2}T_1V + VT_2 + \frac{1}{2}T_3V \\ &= \frac{1}{2} \times \frac{10V^2}{3} + V(552 - T_1 - T_3) + \frac{1}{2}V^2 \\ &= \frac{5}{3}V^2 + 552V - VT_1 - VT_3 + \frac{1}{2}V^2 \\ &= \frac{5}{3}V^2 + 552V - \frac{10V^2}{3} - V^2 + \frac{1}{2}V^2 \\ &= -\frac{13}{6}V^2 + 552V = 12000 \end{aligned}$$

$$-13V^2 + 3312V = 72000$$

$$13V^2 - 3312V + 72000 = 0$$

$$(13V - 3000)(V - 24) = 0$$

$$V = \frac{3000}{13} \text{ or } V = 24$$

First answer is too large because the car would not be able to accelerate to this speed in the time and acceleration given.

$$V = 24 \text{ ms}^{-1}$$

17 i $\frac{1}{2} \times 2.5 \times v = 4$

$$v = \frac{8}{2.5} = 3.2 \text{ ms}^{-1}$$

ii $v = u + at$

$$V = 0 + 3 \times 2$$

$$= 6 \text{ ms}^{-1}$$

iii Let T be the time for which the speed is maintained at V

$$\left(\frac{T+12}{2}\right) \times 6 = 48$$

$$\frac{T+12}{2} = 8$$

$$T+12 = 16$$

$$T = 4 \text{ s}$$

$$4.5 + 4 = 8.5 \text{ s}$$

iv $v = u + at$

$$0 = 6 + 6a$$

$$6a = -6$$

$$a = -1$$

Deceleration = 1 m s^{-2}

Chapter 2

Force and motion in one dimension

EXERCISE 2A

Always write down the equation that you are going to use and then substitute the appropriate values.

1 $F = ma$

$$F = 500 \times 2 = 1000 \text{ N}$$

2 $F = ma$

$$1.2 = 0.3 a$$

$$a = \frac{1.2}{0.3} = 4 \text{ m s}^{-2}$$

3 $F = ma$

$$360 = m \times 1.2$$

$$m = \frac{360}{1.2} = 300 \text{ kg}$$

4

In this question there are two stages in solving the problem. First you need to find the acceleration and then you need to use this to find the distance. Some questions will require both $F = ma$ and the constant acceleration equations to be applied. First look to see if $F = ma$ enables you to find an unknown. If it does not, then you are likely to need the constant acceleration equations first. Either way there will be two stages in your working.

$$F = ma$$

$$42 = 60 a$$

$$a = \frac{42}{60} = 0.7 \text{ m s}^{-2}$$

$$s = ut + \frac{1}{2}at^2$$

$$= 0 \times 10 + \frac{1}{2} \times 0.7 \times 10^2$$

$$= 35 \text{ m}$$

5 a

Note that a negative sign needs to be used for the force in this example. Once you have chosen a positive direction, anything that points in the opposite direction is negative.

$$F = ma$$

$$-0.08 = 0.2a$$

$$a = -\frac{0.08}{0.2} = -0.4 \text{ m s}^{-2}$$

$$v^2 = u^2 + 2as$$

$$v^2 = 1.2^2 - 2 \times 0.4 \times 1 = 0.64$$

$$v = \sqrt{0.64} = 0.8 \text{ m s}^{-1}$$

Note that speed is required here. This is just the 'size' of the velocity, so it will always have a positive value. This is why we have taken the positive square root in this example.

b You need to assume that the balls have no size and that it is possible for them to be 1 m apart.

You may have other assumptions, such as 'there are no other resistance forces'. We often make several assumptions in these questions.

$$6 \quad a = \frac{v - u}{t} = \frac{7 - 3}{8} = 0.5 \text{ m s}^{-2}$$

$$F = ma$$

$$F = 5 \times 0.5 = 2.5 \text{ N}$$

$$7 \quad v^2 = u^2 + 2as$$

$$0 = 10^2 + 2a \times 500$$

$$1000a = -100$$

$$a = -0.1 \text{ m s}^{-2}$$

$$F = ma$$

$$F = 20000 \times -0.1 = -2000 \text{ N}$$

$$\text{Resistance force} = 2000 \text{ N}$$

The negative value of F indicates that it points in the negative direction and resists the motion. The resistance force is the size of this force, so we take the positive value.

$$8 \quad a = \frac{v - u}{t} = \frac{10 - 2}{6} = \frac{4}{3} \text{ m s}^{-2}$$

$$F = ma$$

$$80 = m \times \frac{4}{3}$$

$$m = \frac{80 \times 3}{4} = 60 \text{ kg}$$

$$9 \quad v^2 = u^2 + 2as$$

$$40^2 = 100^2 + 2 \times a \times 100$$

$$200a = -8400$$

$$a = -42 \text{ m s}^{-2}$$

$$F = ma$$

$$F = -800 \times 42 = -33600 \text{ N}$$

$$10 \quad s = ut + \frac{1}{2}at^2$$

$$10 = 0 \times 4 + \frac{1}{2}a \times 4^2$$

$$10 = 0 + 8a$$

$$a = \frac{10}{8} = 1.25 \text{ m s}^{-2}$$

$$F = ma$$

$$100 = m \times 1.25$$

$$m = \frac{100}{1.25} = 80 \text{ kg}$$

$$11 \quad F = ma$$

$$-600 = 1350a$$

$$a = -\frac{600}{1350} = -\frac{4}{9} \text{ m s}^{-2}$$

$$s = ut + \frac{1}{2}at^2$$

$$400 = 30t - \frac{1}{2} \times \frac{4}{9}t^2$$

$$\frac{2}{9}t^2 - 30t + 400 = 0$$

$$2t^2 - 270t + 3600 = 0$$

$$t^2 - 135t + 1800 = 0$$

$$(t - 15)(t - 120) = 0$$

$$t = 15 \text{ s or } 120 \text{ s}$$

$t = 15 \text{ s}$ since this is the first time at which the car will reach the roadworks.

$$\begin{aligned}
 12 \quad v^2 &= u^2 + 2as \\
 0 &= 30^2 + 2a \times 360 \\
 a &= -\frac{900}{720} = -1.25 \text{ m s}^{-2} \\
 F &= ma \\
 -100000 &= -1.25m \\
 m &= 80\,000 \text{ kg}
 \end{aligned}$$

13 In this question the information given shows distances and times, as well as a force. This leaves only two possible equations: $s = ut + \frac{1}{2}at^2$ and $s = \left(\frac{u+v}{2}\right)t$. Given that you need the acceleration, use the first of these two equations. This leaves two unknowns, u and a , but as you are given two pieces of information they can be solved.

First two seconds:

$$\begin{aligned}
 s &= ut + \frac{1}{2}at^2 \\
 8 &= 2u + \frac{1}{2}a \times 2^2 \\
 2u + 2a &= 8 \quad \dots\dots\dots [1]
 \end{aligned}$$

In the first three seconds the block moves $8 + 8.5 = 16.5$ m in total, over $2 + 1 = 3$ seconds:

$$\begin{aligned}
 16.5 &= 3u + \frac{1}{2}a \times 3^2 \\
 33 &= 6u + 9a \\
 2u + 3a &= 11 \quad \dots\dots\dots [2]
 \end{aligned}$$

Subtracting, [2] - [1], gives

$$\begin{aligned}
 a &= 3 \\
 F &= ma \\
 45 &= m \times 3 \\
 m &= \frac{45}{3} = 15 \text{ kg}
 \end{aligned}$$

EXERCISE 2B

- 1 Constant speed, so acceleration = 0 and forces are in equilibrium.

Let R be the air resistance force.

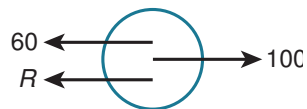

$$100 = 60 + R$$

$$100 - 60 = R$$

$$R = 40 \text{ N}$$

- 2

In this question we show that all four boys are pulling against the adult by subtracting each force P separately. You can, of course, combine them into one force $4P$.

Each of the boys pulls with a force P .

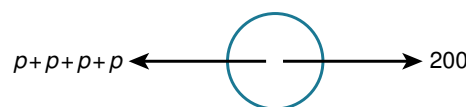

The rope is in equilibrium so the forces balance.

$$200 - P - P - P - P = 0$$

$$4P = 200$$

$$P = \frac{200}{4} = 50 \text{ N}$$

- 3



$F =$ combined force from sailors

Assume that each sailor is able to produce the full force of 300 N.

Let n be the number of sailors.

$$2200 = 300n$$

$$\frac{2200}{300} = 7\frac{1}{3}$$

So 7 sailors pulling with a force of 300 N would not quite manage to overcome the 2200 N resistance.

8 sailors are required as a minimum.

- 4

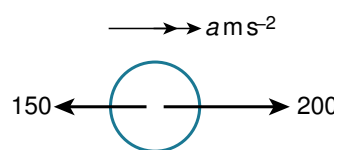

$$F = ma$$

$$200 - 150 = 80a$$

$$a = \frac{50}{80} = 0.625 \text{ m s}^{-2}$$

- 5

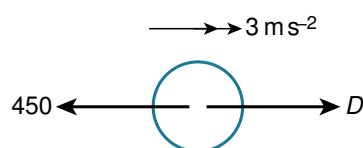

Let the driving force be D .

$$F = ma$$

$$D - 450 = 1500 \times 3$$

$$D = 450 + 4500 = 4950 \text{ N}$$

6

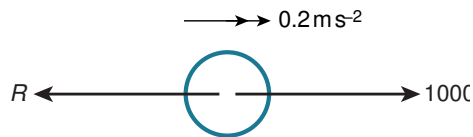

Let the force of resistance be R .

$$F = ma$$

$$1000 - R = 2000 \times 0.2$$

$$R = 1000 - 400 = 600 \text{ N}$$

7

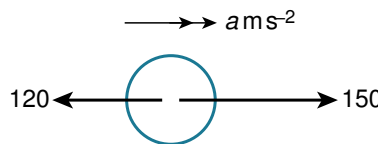

$$F = ma$$

$$150 - 120 = 75a$$

$$a = \frac{30}{75} = 0.4 \text{ m s}^{-2}$$

$$v = u + at$$

$$10 = 0 + 0.4t$$

$$t = \frac{10}{0.4} = 25 \text{ s}$$

8

In this question you should notice that both forces are negative. When the driver presses the brake, there is no driving force and both the braking force and resistance force oppose the motion.

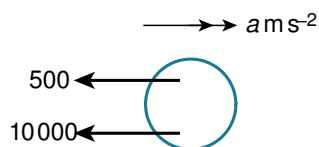

$$F = ma$$

$$-10\,000 - 500 = 1250a$$

$$a = -\frac{10\,500}{1250} = -8.4 \text{ m s}^{-2}$$

$$v^2 = u^2 + 2as$$

$$0 = 21^2 - 2 \times 8.4s$$

$$s = \frac{441}{16.8} = 26.25 \text{ m}$$

9 a

In this question you need to find the acceleration, using an equation for constant acceleration, before you can use $F = ma$.

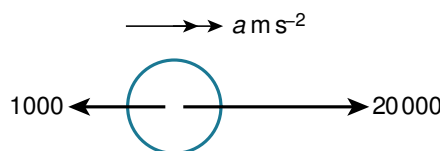

$$v^2 = u^2 + 2as$$

$$80^2 = 0^2 + 2a \times 900$$

$$1800a = 6400$$

$$a = \frac{6400}{1800} = \frac{32}{9} \text{ m s}^{-2}$$

Leave your acceleration as an exact fraction because you need to use its value in the next part of the question. If you give a rounded decimal at this stage, you will introduce an inaccuracy that will be carried through the rest of the question.

$$F = ma$$

$$20000 - 1000 = m \times \frac{32}{9}$$

$$m = \frac{19000 \times 9}{32} = 5340 \text{ kg (3 s. f.)}$$

b We assume that the air resistance is constant throughout the motion along the runway.

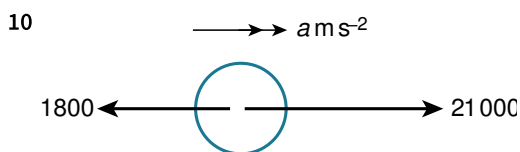

$$F = ma$$

$$21\,000 - 1800 = 600a$$

$$a = \frac{19\,200}{600} = 32 \text{ m s}^{-2}$$

$$v^2 = u^2 + 2as$$

$$v^2 = 0^2 + 2 \times 32 \times 400 = 25\,600$$

$$v = \sqrt{25\,600} = 160 \text{ m s}^{-1}$$

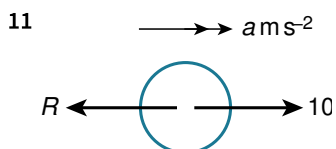

Let the friction force be R .

Avoid confusing the letters used for different quantities. In $F = ma$ the F means resultant force. You cannot then use this for friction. Given that friction is a resistance force we use R here, but you can use anything as long as it doesn't get confused with letters already used.

$$a = \frac{v - u}{t} = \frac{3 - 1}{4} = 0.5 \text{ m s}^{-2}$$

$$F = ma$$

$$10 - R = 6 \times 0.5$$

$$R = 10 - 3 = 7 \text{ N}$$

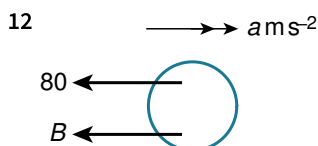

Let the braking force be B .

$$v^2 = u^2 + 2as$$

$$10^2 = 20^2 + 2a \times 250$$

$$500a = 100 - 400 = -300$$

$$a = -0.6 \text{ m s}^{-2}$$

$$F = ma$$

$$-B - 80 = 360 \times -0.6$$

$$B = -80 + 216 = 136 \text{ N}$$

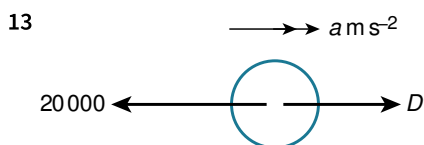

Let the driving force be D .

$$v = u + at$$

$$160 = 240 + a \times 40$$

$$40a = -80$$

$$a = -2 \text{ m s}^{-2}$$

$$F = ma$$

$$D - 20\,000 = 8000 \times -2$$

$$D = 20\,000 - 16\,000 = 4000 \text{ N}$$

14

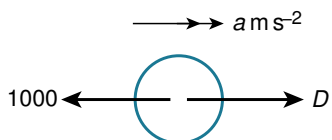

Assume that the driver applies A force P . If P is positive he is applying a driving force. If P is negative then he is applying the brakes.

Assume that the car reduces to the correct speed in exactly 400 m

$$v^2 = u^2 + 2as$$

$$20^2 = 30^2 + 2a \times 400$$

$$800a = 400 - 900 = -500$$

$$a = -0.625 \text{ m s}^{-2}$$

$$F = ma$$

$$P - 1000 = 1400 \times -0.625$$

$$P = 1000 - 1400 \times 0.625 = 125 \text{ N}$$

The driver needs to set the driving force to 125 N. He is slowing the car, so he will be reducing the driving force to this value.

EXERCISE 2C

1 $W = mg = 70 \times 10 = 700 \text{ N}$

2 $W = mg$

$$180 = m \times 10$$

$$m = 18 \text{ kg}$$

3 $s = ut + \frac{1}{2}at^2$

$$-20 = 0 \times t + \frac{1}{2} \times (-10) \times t^2$$

$$-5t^2 = -20$$

$$t^2 = \frac{20}{5} = 4$$

$$t = \pm 2$$

$$t > 0$$

$$t = 2 \text{ s}$$

4 $v^2 = u^2 + 2as$

$$0 = 10^2 + 2 \times (-10)s$$

$$20s = 100$$

$$s = 5 \text{ m}$$

5 $v^2 = u^2 + 2as$

$$v^2 = (-5)^2 + 2 \times (-10) \times -10$$

$$v^2 = 25 + 200 = 225$$

$$v = \pm\sqrt{225} = \pm 15$$

$$\text{Speed} = 15 \text{ m s}^{-1}$$

Make sure that you choose which direction is up and which is down, then stick to your decision without exception. In question 5 the ball is thrown downwards, but 'up' is chosen as positive. This means that both the initial velocity and acceleration are negative, and as displacement is in a downwards direction it is also negative. A speed is required as the final answer, which will be the positive magnitude of the negative velocity.

6 Assume that the wrecking ball hits the ground at exactly the speed required.

$$v^2 = u^2 + 2as$$

$$(-5)^2 = 0^2 + 2 \times (-10)s$$

$$-20s = 25$$

$$s = -1.25 \text{ m}$$

So the ball needs to be dropped from at least 1.25 metres.

Notice that the mass is not used in this question. This is because the acceleration due to gravity does not depend on how heavy the falling object is.

7

Air resistance always works against the motion of the object. In this question 'up' is taken as positive, but the object is falling. So the air resistance is positive, whilst the weight and acceleration are both negative.

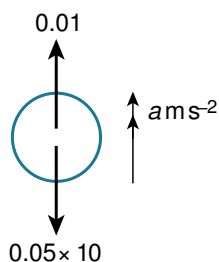

$$F = ma$$

$$-0.05 \times 10 + 0.01 = 0.05 a$$

$$-0.49 = 0.05 a$$

$$a = -\frac{0.49}{0.05} = -9.8 \text{ m s}^{-2}$$

$$v^2 = u^2 + 2as$$

$$v^2 = 0^2 + 2 \times (-9.8) \times (-300) = 5880$$

$$v = \sqrt{5880} = 76.7 \text{ m s}^{-2}$$

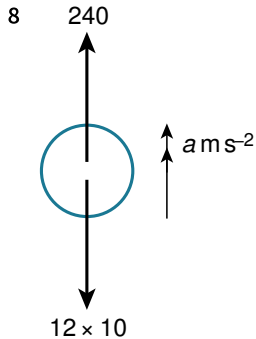

While accelerating:

$$F = ma$$

$$240 - 12 \times 10 = 12 a$$

$$12a = 120$$

$$a = 10 \text{ m s}^{-2}$$

Time taken:

$$v = u + at$$

$$10 = 0 + 10t$$

$$t = 1 \text{ s}$$

Height gained while accelerating:

$$s = ut + \frac{1}{2}at^2$$

$$s = 0 \times 1 + \frac{1}{2} \times 10 \times 1^2 = 5 \text{ m}$$

Remaining distance to travel = $40 - 5 = 35$ metres, at a constant speed of 10 m s^{-2}

$$s = vt$$

$$35 = 10t$$

$$t = 3.5 \text{ s}$$

Total time = $3.5 + 1 = 4.5 \text{ s}$

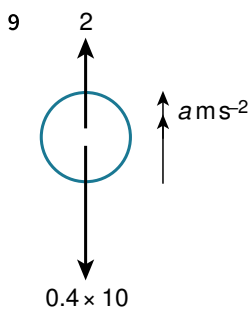

$$F = ma$$

$$2 - 0.4 \times 10 = 0.4 a$$

$$a = \frac{2 - 4}{0.4} = -5 \text{ m s}^{-2}$$

$$s = ut + \frac{1}{2}at^2$$

$$s = 40 \times 6 + \frac{1}{2} \times (-5) \times 6^2$$

$$= 240 - 90 = 150 \text{ m}$$

- 10 a In this question it is very important to remember that, because the force produced by the flare itself is always upwards, then the acceleration for the two parts of the motion, 'up' and 'down' will be the same. This means that we do not need to consider the two parts of the motion separately, because the acceleration is constant.

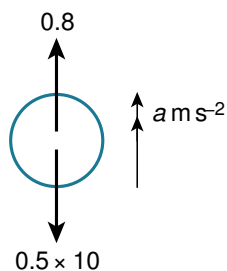

$$F = ma$$

$$0.8 - 0.5 \times 10 = 0.5a$$

$$0.5a = -4.2$$

$$a = -8.4 \text{ m s}^{-2}$$

Time to reach 25 m:

$$s = ut + \frac{1}{2}at^2$$

$$25 = 30t + \frac{1}{2} \times (-8.4)t^2$$

$$4.2t^2 - 30t + 25 = 0$$

$$42t^2 - 300t + 250 = 0$$

$$21t^2 - 150t + 125 = 0$$

$$t = \frac{-(-150) \pm \sqrt{(-150)^2 - 4 \times 21 \times 125}}{2 \times 21}$$

$$= 0.96323 \text{ or } 6.1796$$

The flare is above 25 metres between these two times, so the total time above 25 m is the difference between the two times.

$$6.1796 - 0.9632 = 5.22 \text{ s (3 s. f.)}$$

- b The force provided by the flare remains vertical and in line with the weight.

There are other assumptions you could have made; for example, the mass of the flare does not change or there is no air resistance.

- 11 Let the air resistance be R .

$$s = ut + \frac{1}{2}at^2$$

$$-3 = 0 \times 2 + \frac{1}{2}a \times 2^2$$

$$2a = -3$$

$$a = -1.5 \text{ m s}^{-2}$$

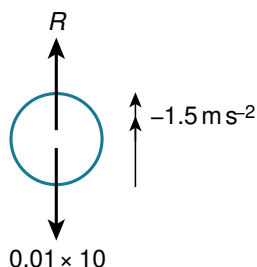

$$F = ma$$

$$-0.01 \times 10 + R = 0.01 \times -1.5$$

$$R = -0.015 + 0.1 = 0.085 \text{ N}$$

- 12 For this question you once again need to remember that air resistance always opposes motion, whereas the weight is always vertically downwards. As the ball rises, the air resistance and weight both point downwards. However, as the ball falls the air resistance is a positive upwards force, while the weight still acts downwards so is

negative.

Going up, to find the maximum height.

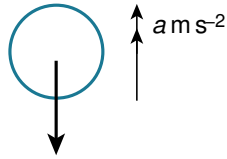

$$0.3 \times 10 + 0.15$$

$$F = ma$$

$$-0.3 \times 10 - 0.15 = 0.3a$$

$$a = -\frac{3.15}{0.3} = -10.5 \text{ m s}^{-2}$$

$$v^2 = u^2 + 2as$$

$$0 = 10^2 + 2 \times (-10.5)s$$

$$s = \frac{100}{21} \text{ m}$$

From the highest point the ball needs to fall $\frac{100}{21} + 1.2 \text{ m}$

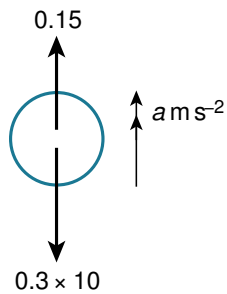

$$F = ma$$

$$0.15 - 0.3 \times 10 = 0.3a$$

$$a = -\frac{2.85}{0.3} = -9.5 \text{ m s}^{-2}$$

$$v^2 = u^2 + 2as$$

$$v^2 = 0^2 + 2 \times (-9.5) \times \left(-\frac{100}{21} - 1.2\right)$$

$$v^2 = 113.276 \dots$$

$$v = \sqrt{113.276 \dots} = 10.6 \text{ m s}^{-1}$$

13 a Speed of initial impact:

$$v^2 = u^2 + 2as$$

$$v^2 = 0^2 + 2 \times (-10) \times (-5) = 100$$

$$v = 10 \text{ m s}^{-1}$$

Upward motion, with initial speed: $10 \times 0.8 = 8 \text{ m s}^{-1}$

$$v^2 = u^2 + 2as$$

$$0 = 8^2 + 2 \times (-10)s$$

$$20s = 64$$

$$s = 3.2 \text{ m}$$

b If, instead, the acceleration due to gravity is g , the working above becomes:

Speed of initial impact:

$$v^2 = u^2 + 2as$$

$$v^2 = 0^2 + 2 \times (-g) \times (-5) = 10g$$

$$v = \sqrt{10g}$$

Upward motion, with initial speed: $\sqrt{10g} \times 0.8 = 0.8\sqrt{10g}$

$$v^2 = u^2 + 2as$$

$$0 = (0.8\sqrt{10g})^2 + 2 \times (-g)s$$

$$2gs = 0.8^2 \times 10g$$

$$s = \frac{0.8^2 \times 10g}{2g} = \frac{0.64 \times 10}{2} = 3.2 \text{ m}$$

This answer does not depend on g . Notice that it is exactly the same answer as in part (a).

14 Speed after falling 1400 m:

$$v^2 = u^2 + 2as$$

$$v^2 = 0^2 + 2 \times (-10) \times (-1400)$$

$$v^2 = 28000$$

The final speed, v , of this part of the motion becomes the initial speed, u , of the next. We will use the same equation, so there is no need to take the square root of 28000.

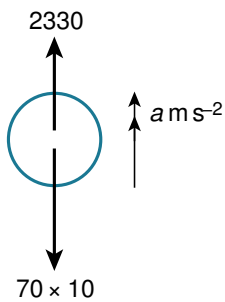

$$F = ma$$

$$2330 - 70 \times 10 = 70a$$

$$a = \frac{1630}{70} = \frac{163}{7}$$

$$v^2 = u^2 + 2as$$

$$v^2 = 28000 + 2 \times \frac{163}{7} \times (-600)$$

$$v = \sqrt{28000 + 2 \times \frac{163}{7} \times (-600)} = 7.56 \text{ m s}^{-1}$$

15 Height of first ball at time t seconds after the first ball is thrown.

$$s = ut + \frac{1}{2}at^2$$

$$s = 10t + \frac{1}{2} \times (-10)t^2 = 10t - 5t^2$$

Second ball has been travelling $t - 1$ seconds, t seconds after the first ball is thrown.

$$s = 8(t - 1) + \frac{1}{2} \times (-10)(t - 1)^2$$

$$s = 8t - 8 - 5(t^2 - 2t + 1)$$

$$s = 8t - 8 - 5t^2 + 10t - 5$$

$$s = 18t - 13 - 5t^2$$

The two balls reach the same height when

$$18t - 13 - 5t^2 = 10t - 5t^2$$

$$8t - 13 = 0$$

$$8t = 13$$

$$t = \frac{13}{8}$$

$$s = 10 \left(\frac{13}{8} \right) - 5 \left(\frac{13}{8} \right)^2 = 3.05 \text{ m}$$

16 Let the depth of the well be d .

$$s = ut + \frac{1}{2}at^2$$

$$-d = 0t + \frac{1}{2} \times (-10) \times t^2$$

$$5t^2 = d$$

$$t^2 = \frac{d}{5}$$

$$t = \sqrt{\frac{d}{5}}$$

Time taken for the sound to return from the bottom of the well:

$$s = vt$$

$$d = 340t$$

$$t = \frac{d}{340}$$

Total time 5 seconds, so

$$\sqrt{\frac{d}{5}} + \frac{d}{340} = 5$$

$$\sqrt{d} + \frac{d\sqrt{5}}{340} = 5\sqrt{5}$$

$$340\sqrt{d} + d\sqrt{5} = 1700\sqrt{5}$$

$$\sqrt{5}(\sqrt{d})^2 + 340\sqrt{d} - 1700\sqrt{5} = 0$$

$$\sqrt{d} = \frac{-340 \pm \sqrt{340^2 - 4 \times \sqrt{5} \times (-1700\sqrt{5})}}{2\sqrt{5}}$$

$$= -162.51 \dots \text{ or } 10.461 \dots$$

$$d = 10.461^2 = 109 \text{ m (3 s. f.)}$$

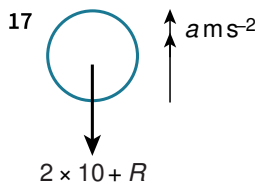

$$F = ma$$

$$-20 - R = 2a$$

$$a = -10 - \frac{1}{2}R$$

Maximum height:

$$v^2 = u^2 + 2as$$

$$0 = 20^2 + 2 \left(-10 - \frac{1}{2}R \right) s$$

$$0 = 400 - 20s - Rs$$

$$(20 + R)s = 400$$

$$s = \frac{400}{20 + R}$$

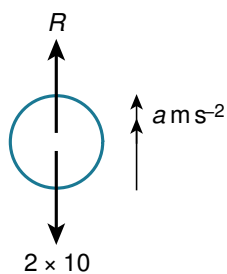

$$F = ma$$

$$R - 20 = 2a$$

$$a = \frac{1}{2}R - 10$$

$$v^2 = u^2 + 2as$$

$$15^2 = 0^2 + 2 \left(\frac{1}{2}R - 10 \right) \times \frac{-400}{20 + R}$$

$$225 = -400 \frac{(R - 20)}{20 + R}$$

$$4500 + 225R = -400R + 8000$$

$$625R = 3500$$

$$R = 5.6 \text{ N}$$

EXERCISE 2D

1

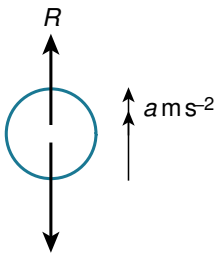

$$70 \times 10 = 700$$

$$a = \frac{v - u}{t} = \frac{10 - 0}{2} = 5 \text{ m s}^{-2}$$

Taking upwards as positive

$$F = ma$$

$$R - 700 = 70 \times 5$$

$$R = 700 + 350$$

$$= 1050 \text{ N}$$

2 $v^2 = u^2 + 2as$

$$0 = 8^2 + 2a \times 9$$

$$a = -\frac{64}{18} = -\frac{32}{9} \text{ m s}^{-2}$$

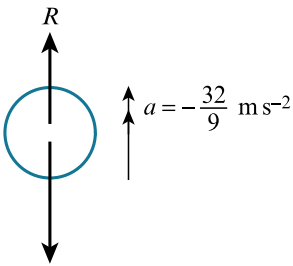

$$55 \times 10 = 550$$

Taking upwards as positive

$$R - 550 = 55 \times \left(-\frac{32}{9}\right)$$

$$R = 550 - \frac{55 \times 32}{9} = 354 \text{ N (3 s. f.)}$$

3 $a = \frac{v - u}{t} = \frac{-7 - 0}{2} = -3.5 \text{ m s}^{-2}$

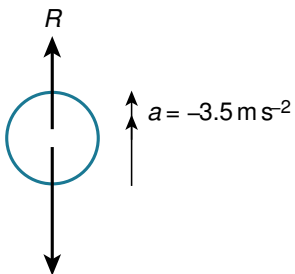

$$30 \times 10 = 300$$

Taking upwards as positive

$$R - 300 = 30 \times (-3.5)$$

$$R = 300 - 105$$

$$= 195 \text{ N}$$

$$4 \quad v^2 = u^2 + 2as$$

$$0 = 8^2 + 2a \times (-6.25)$$

$$a = \frac{6.4}{12.5} = 5.12 \text{ m s}^{-2}$$

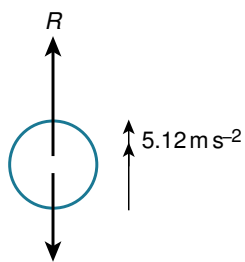

$$40 \times 10 = 400$$

Taking up as positive

$$R - 400 = 40a$$

$$R = 400 + 40 \times 5.12$$

$$= 605 \text{ N}$$

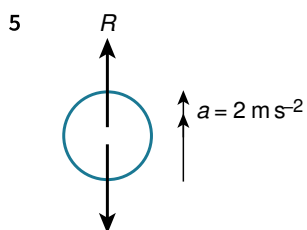

$$35 \times 10 = 350$$

Taking upwards as positive

$$R - 350 = 35 \times 2 = 70$$

$$R = 350 + 70 = 420 \text{ N}$$

Notice that the question is about the force on, and acceleration of, the tiles and not the pallet. Therefore the diagram does not include the pallet, but it does include the force that the pallet exerts on the tiles. Given that the tiles would fall to the ground if not supported by the pallet, the pallet must be exerting an upward force on the tiles.

6 The weightlifter provides an upward force. The normal contact force from the floor is also directed upwards.

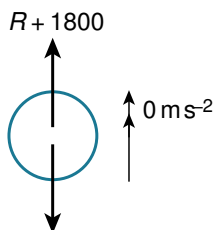

$$200 \times 10 = 2000$$

$$R + 1800 - 2000 = 200 \times 0$$

$$R = 2000 - 1800 = 200 \text{ N}$$

$$7 \quad s = ut + \frac{1}{2}at^2$$

$$1.25 = 0 \times 5 + \frac{1}{2}a \times 5^2$$

$$25a = 2.5$$

$$a = 0.1 \text{ m s}^{-2}$$

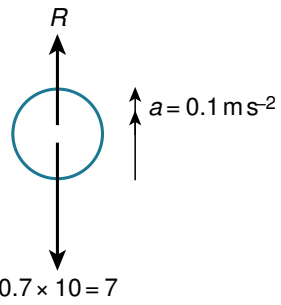

$$R - 7 = 0.7 \times 0.1$$

$$R = 7.07 \text{ N}$$

8

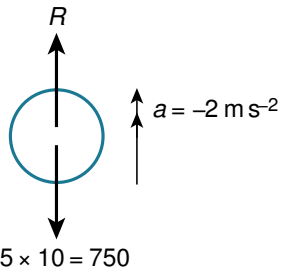

$$a = \frac{v - u}{t} = \frac{-3 - 5}{4} = -2 \text{ ms}^{-2}$$

$$R - 750 = 75 \times (-2) = -150$$

$$R = 750 - 150 = 600 \text{ N}$$

9 a

$$v^2 = u^2 + 2as$$

$$40^2 = 0^2 + 2a \times 200$$

$$400a = 1600$$

$$a = 4 \text{ ms}^{-2}$$

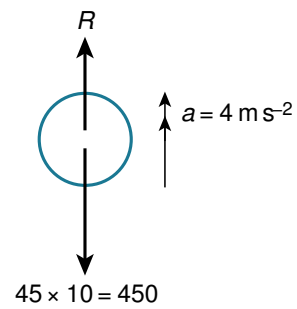

$$R - 450 = 45 \times 4 = 180$$

$$R = 180 + 450 = 630 \text{ N}$$

b The girl is modelled as a particle and so only touches the helicopter in one place.

10

$$s = ut + \frac{1}{2}at^2$$

$$-22 = 0 \times 2 + \frac{1}{2}a \times 2^2$$

$$-22 = 2a$$

$$a = -11 \text{ ms}^{-2}$$

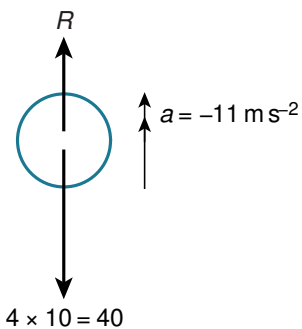

$$R - 40 = 4 \times (-11)$$

$$R = 40 - 44 = -4\text{ N}$$

Overall there is a 4 N normal contact force downwards, so the force acts from the top pad.

END-OF-CHAPTER REVIEW EXERCISE 2

1 $\longrightarrow a \text{ m s}^{-2}$

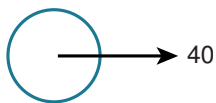

$$F = ma$$

$$40 = 80a$$

$$a = 0.5 \text{ m s}^{-2}$$

$$v^2 = u^2 + 2as$$

$$12^2 = 10^2 + 2 \times 0.5s$$

$$s = 144 - 100 = 44 \text{ m}$$

2 $s = ut + \frac{1}{2}at^2$

$$5 = 0 + \frac{1}{2}a \times 8^2$$

$$32a = 5$$

$$a = \frac{5}{32}$$

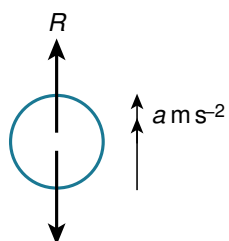

$$20 \times 10 = 200$$

Taking upwards as positive

$$F = ma$$

$$R - 200 = 20a$$

$$R = 200 + \frac{100}{32} = 203 \text{ N (3 s. f.)}$$

3 $v = u + at$

$$4 = 0 + 20a$$

$$a = 0.2 \text{ m s}^{-2}$$

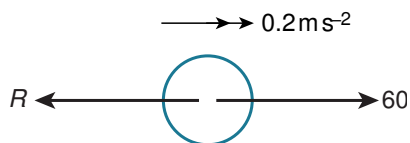

$$60 - R = 100 \times 0.2$$

$$60 - R = 20$$

$$R = 40 \text{ N}$$

4 a 0.4

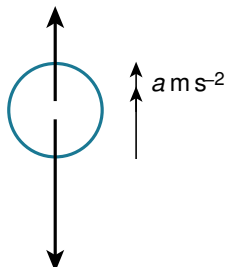

$$0.3 \times 10 = 3$$

Taking upwards as positive

$$F = ma$$

$$0.4 - 3 = 0.3 a$$

$$-2.6 = 0.3 a$$

$$a = -\frac{26}{3} \text{ m s}^{-2}$$

$$v^2 = u^2 + 2 as$$

$$v^2 = 0 + 2 \times \left(-\frac{26}{3}\right) \times (-40)$$

$$v = \sqrt{2 \times \left(-\frac{26}{3}\right) \times (-40)} = 26.3 \text{ m s}^{-1} \text{ (3 s.f.)}$$

Always avoid using decimals if you possible can. The moment you use a rounded answer to get another answer, there is a good chance that you will introduce an error.

b $s = ut + \frac{1}{2} at^2$

$$-40 = 0 + \frac{1}{2} \times \left(-\frac{26}{3}\right) t^2$$

$$t^2 = \frac{40 \times 6}{26} = \frac{120}{13}$$

$$t = \sqrt{\frac{120}{13}}$$

Time taken for the sound to return.

$$s = vt$$

$$40 = 340t$$

$$t = \frac{4}{34} \text{ s}$$

$$\text{Total time} = \frac{4}{34} + \sqrt{\frac{120}{13}} = 3.16 \text{ s}$$

5 a

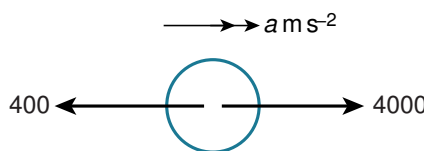

$$F = ma$$

$$4000 - 400 = 9000 a$$

$$a = \frac{3600}{9000} = 0.4 \text{ m s}^{-2}$$

$$v = u + at$$

$$48 = 0 + 0.4 t$$

$$t = \frac{48}{0.4} = 120 \text{ s}$$

b

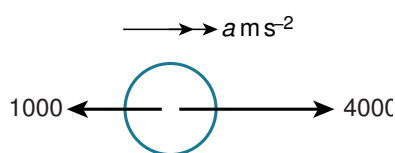

$$F = ma$$

$$4000 - 1000 = 9000 a$$

$$a = \frac{3000}{9000} = \frac{1}{3} \text{ m s}^{-2}$$

$$v^2 = u^2 + 2 as$$

$$v^2 = 48^2 + 2 \times \frac{1}{3} \times 400$$

$$v = \sqrt{48^2 + \frac{800}{3}} = 50.7 \text{ m s}^{-1} \text{ (3 s.f.)}$$

6 a $v^2 = u^2 + 2as$
 $0 = 11^2 + 2a \times 4000$
 $8000a = -121$
 $a = -0.015125$

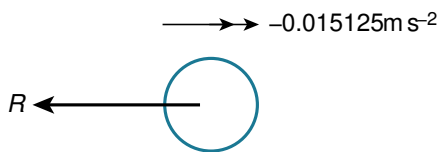

Using $F = ma$

$$-R = 20\,000\,000 \times (-0.015125)$$

$$R = 3\,025\,000 \text{ N}$$

b $v^2 = u^2 + 2as$
 $0 = 14^2 + 2 \times (-0.015125)s$
 $s = \frac{14^2}{2 \times 0.015125} = 6480 \text{ m (3 s. f.)}$

c Higher maximum speed under water suggests that resistance must be less when fully immersed.

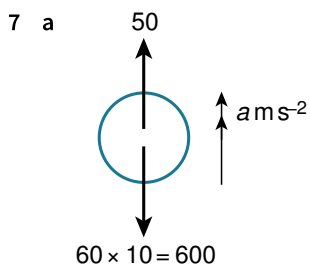

$$60 \times 10 = 600$$

Using $F = ma$

$$50 - 600 = 60a$$

$$a = -\frac{55}{6} \text{ m s}^{-2}$$

$$v^2 = u^2 + 2as$$

$$v^2 = 0 + 2 \times \left(-\frac{55}{6}\right) \times (-10)$$

$$v = \sqrt{\frac{55 \times 20}{6}} = 13.5 \text{ m s}^{-1} \text{ (3 s. f.)}$$

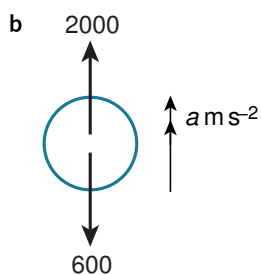

$$F = ma$$

$$2000 - 600 = 60a$$

$$a = \frac{1400}{60} = \frac{70}{3} \text{ m s}^{-2}$$

$$v^2 = u^2 + 2as$$

$$0 = \frac{55 \times 20}{6} + 2 \times \frac{70}{3} s$$

$$\frac{140}{3} s = -\frac{55 \times 20}{6}$$

$$s = -\frac{55 \times 20}{6} \times \frac{3}{140} = 3.93 \text{ m (3 s. f.)}$$

8

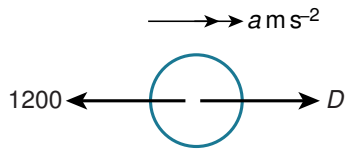

$$v^2 = u^2 + 2as$$

$$0 = 15^2 + 2a \times 40$$

$$80a = -225$$

$$a = -\frac{225}{80}$$

$$F = ma$$

$$D - 1200 = 400 \times \left(-\frac{225}{80}\right)$$

$$D = 1200 - 1125 = 75 \text{ N}$$

Positive driving force required, so accelerate with force 75 N

9

When an object is moving vertically, the weight always acts downwards and doesn't change direction. Air resistance will change direction if you change the direction of motion.

$$\mathbf{a} \quad v^2 = u^2 + 2as$$

$$0 = 9^2 + 2a \times 3$$

$$6a = -81$$

$$a = -\frac{27}{2} \text{ m s}^{-2}$$

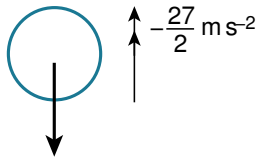

$$R + 0.1 \times 10$$

Using $F = ma$

$$-R - 1 = 0.1 \times \left(-\frac{27}{2}\right)$$

$$R = \frac{27 \times 0.1}{2} - 1 = 0.35 \text{ N}$$

b

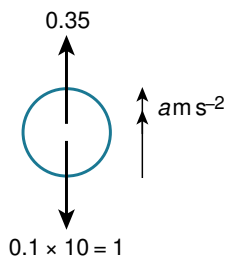

$$0.1 \times 10 = 1$$

$$F = ma$$

$$0.35 - 1 = 0.1a$$

$$a = -\frac{0.65}{0.1} = -6.5 \text{ m s}^{-2}$$

$$v^2 = u^2 + 2as$$

$$v^2 = 0 + 2 \times (-6.5) \times (-3)$$

$$v = \sqrt{6 \times 6.5} = \sqrt{39} = 6.24 \text{ m s}^{-1} \text{ (3 s. f.)}$$

10 With air resistance only:

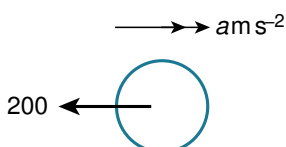

$$F = ma$$

$$-200 = 350a$$

$$a = -\frac{200}{350} = -\frac{4}{7} \text{ m s}^{-2}$$

With braking added:

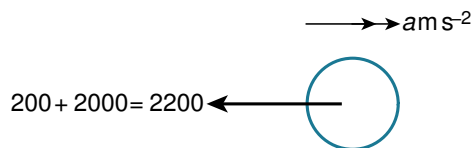

$$-2200 = 350a$$

$$a = -\frac{2200}{350} = -\frac{44}{7} \text{ m s}^{-2}$$

At distance s metres from the junction, the distance travelled is $100 - s$

$$v^2 = 30^2 + 2 \times \left(-\frac{4}{7}\right)(100 - s)$$

$$= 900 - \frac{8}{7}(100 - s)$$

Final section of motion

$$0^2 = 900 - \frac{8}{7}(100 - s) + 2 \times \left(-\frac{44}{7}\right)s$$

$$\left(-\frac{8}{7} + \frac{88}{7}\right)s = 900 - \frac{800}{7}$$

$$s = 68.75 \text{ m}$$

11 a

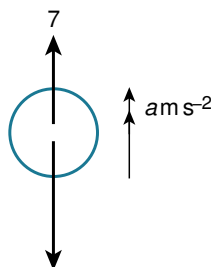

$$0.3 \times 10 = 3$$

$$7 - 3 = 0.3a$$

$$a = \frac{4}{0.3} = \frac{40}{3} \text{ m s}^{-2}$$

Height and speed after 3 seconds:

$$v = u + at$$

$$= 0 + \frac{40}{3} \times 3 = 40 \text{ m s}^{-1}$$

$$s = ut + \frac{1}{2}at^2$$

$$= 0 + \frac{1}{2} \times \frac{40}{3} \times 3^2 = 60 \text{ m}$$

Acceleration due to gravity acts alone from this point:

$$v^2 = u^2 + 2as$$

$$0 = 40^2 + 2 \times (-10)s$$

$$20s = 1600$$

$$s = 80 \text{ m}$$

Total height = $80 + 60 = 140 \text{ m}$

b Time taken for the second part of the flight

$$s = \left(\frac{u + v}{2}\right)t$$

$$80 = \left(\frac{40 + 0}{2}\right)t$$

$$t = 4 \text{ s}$$

$$\text{Total time} = 4 + 3 = 7\text{s}$$

$$\text{Fuse length} = 7 \times 12 = 84\text{ mm}$$

12 $\longrightarrow a\text{ m s}^{-2}$

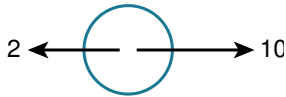

$$10 - 2 = 5a$$

$$a = \frac{8}{5} = 1.6\text{ m s}^{-2}$$

If the boy drops the cart after T seconds

$$s = ut + \frac{1}{2}at^2$$

$$s = 0 + \frac{1}{2} \times 1.6T^2 = 0.8T^2$$

Speed at this time:

$$v = u + at = 1.6T$$

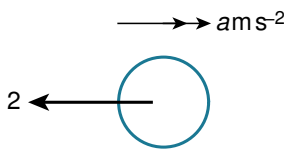

$$-2 = 5a$$

$$a = -0.4\text{ m s}^{-2}$$

$$v^2 = u^2 + 2as$$

$$0 = (1.6T)^2 + 2 \times (-0.4)s$$

$$0.8s = (1.6T)^2$$

$$s = \frac{(1.6T)^2}{0.8}$$

Total distance = 36 m

$$0.8T^2 + \frac{(1.6T)^2}{0.8} = 36$$

$$0.8T^2 + \frac{1.6^2T^2}{0.8} = 36$$

$$4T^2 = 36$$

$$T^2 = 9$$

$T = 3$ seconds

13 Stone and pallet combined

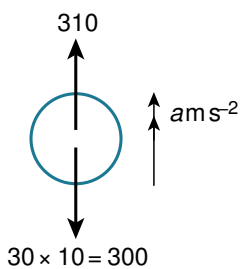

$$30 \times 10 = 300$$

$$F = ma$$

$$310 - 300 = 30a$$

$$a = \frac{1}{3}\text{ m s}^{-2}$$

Speed at point pallet stops

$$v^2 = u^2 + 2as$$

$$v^2 = 0^2 + 2 \times \frac{1}{3} \times 8$$

$$v = \sqrt{\frac{16}{3}}$$

Now under gravity only

$$v^2 = u^2 + 2as$$

$$0 = \left(\sqrt{\frac{16}{3}}\right)^2 + 2 \times (-10)s$$

$$20s = \frac{16}{3}$$

$$s = \frac{16}{60}$$

$$\text{Total height} = 8 + \frac{16}{60} = 8.27 \text{ m}$$

14 a $\longrightarrow \rightarrow a \text{ m s}^{-2}$



$$F = ma$$

$$-R = 0.05 a$$

$$a = -20 R$$

Puck hits the side with what speed?

$$v^2 = u^2 + 2as$$

$$v^2 = 4^2 + 2 \times (-20R) \times 1$$

$$= 16 - 40R$$

$$v = \sqrt{16 - 40R}$$

Rebound speed

$$= 0.8\sqrt{16 - 40R}$$

Stops after what distance?

$$v^2 = u^2 + 2as$$

$$0 = 0.8^2(16 - 40R) + 2(-20R)s$$

$$40Rs = 0.8^2(16 - 40R)$$

$$s = \frac{0.8^2(16 - 40R)}{40R}$$

The puck will return to the centre if:

$$s \geq 1$$

$$\frac{0.8^2(16 - 40R)}{40R} \geq 1$$

$$0.8^2(16 - 40R) \geq 40R$$

$$16 - 40R \geq 62.5R$$

$$102.5R \leq 16$$

$$R \leq \frac{16}{102.5}$$

$$R \leq \frac{32}{205}$$

b Puck leaves first side with speed:

$$0.8\sqrt{16 - 40R}$$

What is its speed at the opposite end?

$$v^2 = u^2 + 2as$$

$$v^2 = 0.8^2(16 - 40R) + 2 \times (-20R) \times 2$$

$$= 10.24 - 25.6R - 80R$$

$$= 10.24 - 105.6R$$

Rebound speed

$$= 0.8\sqrt{10.24 - 105.6R}$$

Distance to stop from this speed

$$v^2 = u^2 + 2as$$

$$0 = 0.8^2(10.24 - 105.6R) + 2 \times (-20R) \times s$$

$$40Rs = 0.8^2(10.24 - 105.6R)$$

$$s = \frac{0.8^2(10.24 - 105.6R)}{40R}$$

$$\frac{0.8^2(10.24 - 105.6R)}{40R} < 1$$

$$6.5536 - 67.584R < 40R$$

$$107.584R > 6.5536$$

$$R > \frac{6.5536}{107.584}$$

$$R > 0.0609$$

15 i Maximum height

$$v^2 = u^2 + 2as$$

$$0 = 8^2 + 2 \times (-10)s$$

$$20s = 64$$

$$s = \frac{64}{20} = 3.2 \text{ m}$$

Speed at height 1.6 m

$$v^2 = u^2 + 2as$$

$$v^2 = 8^2 + 2 \times (-10) \times 1.6$$

$$= 64 - 32$$

$$v = \sqrt{32} = 5.66 \text{ m s}^{-1}$$

ii

$$s = ut + \frac{1}{2}at^2$$

$$1.6 = 8t + \frac{1}{2} \times (-10)t^2$$

$$3.2 = 16t - 10t^2$$

$$10t^2 - 16t + 3.2 = 0$$

$$t^2 - 1.6t + 0.32 = 0$$

$$t = \frac{-(-1.6) \pm \sqrt{(-1.6)^2 - 4 \times 1 \times 0.32}}{2 \times 1}$$

$$t = 0.234 \text{ s or } 1.37$$

Question requires time on the way up

$$t = 0.234 \text{ s}$$

You can also solve this part of the question using the value calculated in part i:

$$v = u + at$$

$$\sqrt{32} = 8 + (-10)t$$

$$10t = 8 - \sqrt{32}$$

$$t = \frac{8 - \sqrt{32}}{10} = 0.234 \text{ s}$$

16 i

$$s = ut + \frac{1}{2}at^2$$

$$15 = 20t + \frac{1}{2} \times (-10)t^2$$

$$15 = 20t - 5t^2$$

$$5t^2 - 20t + 15 = 0$$

$$t^2 - 4t + 3 = 0$$

$$(t - 1)(t - 3) = 0$$

$$t = 1 \text{ or } t = 3$$

Total time above 15 metres

$$3 - 1 = 2 \text{ s}$$

ii Height of P after t seconds

$$s = ut + \frac{1}{2}at^2$$

$$= 20t - 5t^2$$

Height of Q after t seconds Q will have been travelling for $t - 0.4$ seconds)

$$s = 25(t - 0.4) + \frac{1}{2} \times (-10) \times (t - 0.4)^2$$

$$= 25t - 10 - 5(t - 0.4)^2$$

The height will be the same when

$$20t - 5t^2 = 25t - 10 - 5(t - 0.4)^2$$

$$20t - 5t^2 = 25t - 10 - 5t^2 + 4t - 0.8$$

$$9t = 10.8$$

$$t = 1.2 \text{ s}$$

$$v = u + at$$

$$v(P) = 20 + (-10) \times 1.2 = 20 - 12 = 8 \text{ m s}^{-1}$$

$$v(Q) = 25 + (-10)(1.2 - 0.4) = 25 - 8 = 17 \text{ m s}^{-1}$$

17

For some questions you may find it easier to take 'down' as positive, as we have in part **i** below. But you always need to make it clear that you have done this. Remember that the velocity-time graph will always have 'up' as positive.

i

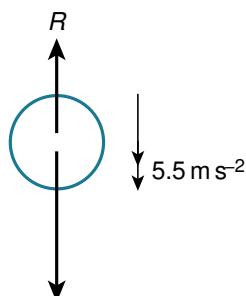

$$3 \times 10 = 30$$

$$30 - R = 3 \times 5.5$$

$$R = 30 - 16.5 = 13.5 \text{ N}$$

ii Speed with which it reaches liquid:

$$v^2 = u^2 + 2as$$

$$v^2 = 0 + 2 \times 10 \times 5 = 100$$

$$v = 10 \text{ m s}^{-1}$$

Time at which it reaches liquid:

$$s = ut + \frac{1}{2}at^2$$

$$5 = 0 + \frac{1}{2} \times 10 \times t^2$$

$$5t^2 = 5$$

$$t = \pm 1$$

$$t > 0$$

$$t = 1$$

Speed after travelling all the way through the liquid:

$$v^2 = u^2 + 2as$$

$$v^2 = 10^2 + 2 \times 5.5 \times 4$$

$$= 100 + 44$$

$$= 144$$

$$v = \sqrt{144} = 12 \text{ m s}^{-1}$$

Time to pass through the liquid:

$$4 = 10t + \frac{1}{2} \times 5.5 t^2$$

$$8 = 20t + 5.5 t^2$$

$$5.5t^2 + 20t - 8 = 0$$

$$11t^2 + 40t - 16 = 0$$

$$t = \frac{4}{11} \text{ or } t = -4$$

$$t > 0$$

$$t = \frac{4}{11} \text{ so total time to bottom} = 1 + 0.364 = 1.36 \text{ s (3 s. f.)}$$

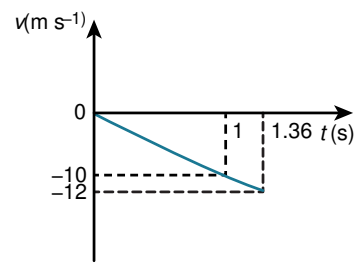

In the velocity–time graph ‘up’ is positive and so the velocities we have calculated are plotted as negative values.

Chapter 3

Forces in two dimensions

EXERCISE 3A

1

When resolving forces into perpendicular components always draw a clear right-angled triangle on your diagram. Use dotted lines to indicate components; non-dotted lines should only be used for the diagram itself and resultant forces.

i

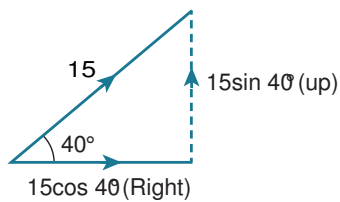

a $15 \cos 40^\circ = 11.5 \text{ N to the right}$

b $15 \sin 40^\circ = 9.64 \text{ N upwards}$

ii

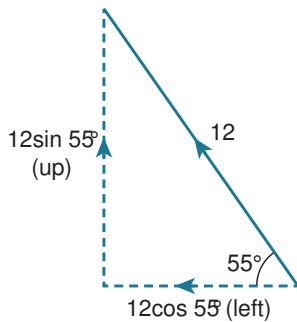

a $12 \cos 55^\circ = 6.88 \text{ N to the left}$

b $12 \sin 55^\circ = 9.83 \text{ N upwards}$

iii

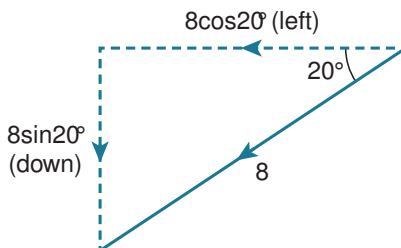

a $8 \cos 20^\circ = 7.52 \text{ N to the left}$

b $8 \sin 20^\circ = 2.74 \text{ N downwards}$

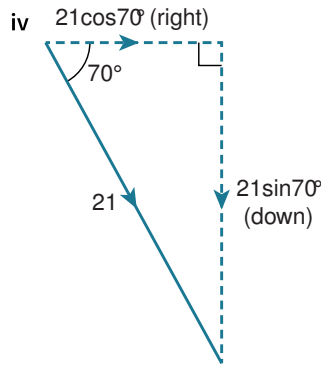

a $21 \cos 70^\circ = 7.18 \text{ N to the right}$

b $21 \sin 70^\circ = 19.7 \text{ N downwards}$

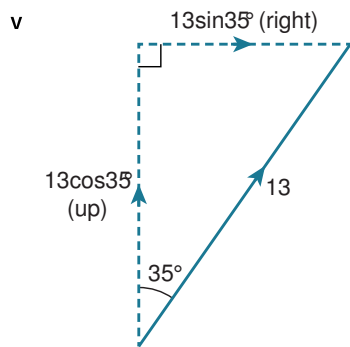

a $13 \sin 35^\circ = 7.46 \text{ N to the right}$

b $13 \cos 35^\circ = 10.6 \text{ N upwards}$

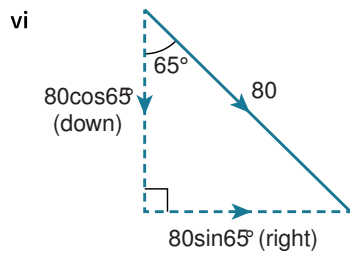

a $80 \sin 65^\circ = 72.5 \text{ N to the right}$

b $80 \cos 65^\circ = 33.8 \text{ N downwards}$

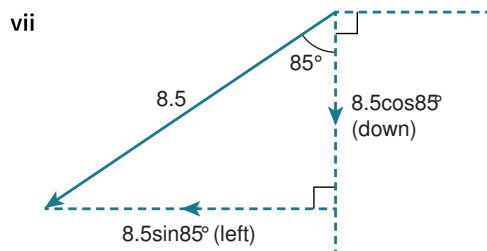

a $8.5 \sin 85^\circ = 8.47 \text{ N to the left}$

b $8.5 \cos 85^\circ = 0.741 \text{ N downwards}$

viii

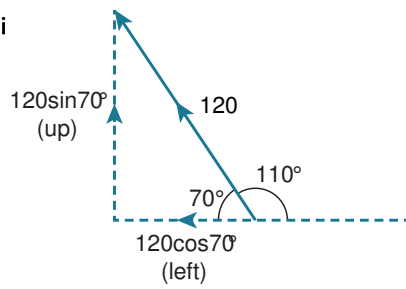

a $120 \cos 70^\circ = 41.0 \text{ N to the left}$

b $120 \sin 70^\circ = 113 \text{ N upwards}$

In all of the examples in question 1, the force given was the resultant of the two components that you were asked to find. This is why the given force is placed on the hypotenuse of the triangle in each case.

2 a

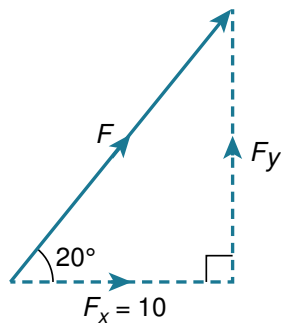

$$F_x = F \cos 20^\circ$$

$$F \cos 20^\circ = 10$$

$$F = \frac{10}{\cos 20^\circ} = 10.6 \text{ N}$$

$$F_y = F \sin 20^\circ = \frac{10 \sin 20^\circ}{\cos 20^\circ} = 3.64 \text{ N (upwards)}$$

b

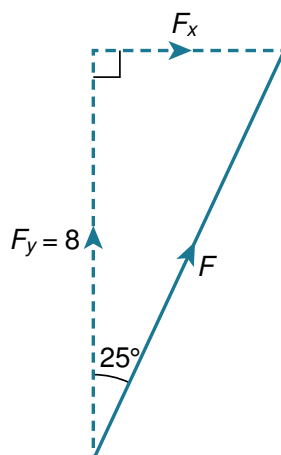

$$F_y = F \cos 25^\circ$$

$$F \cos 25^\circ = 8$$

$$F = \frac{8}{\cos 25^\circ} = 8.83 \text{ N}$$

$$F_x = F \sin 25^\circ = \frac{8 \sin 25^\circ}{\cos 25^\circ} = 3.73 \text{ N (right)}$$

c

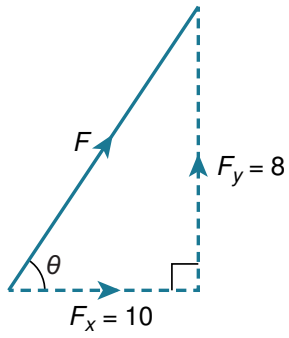

$$F^2 = 8^2 + 10^2 = 164$$

$$F = \sqrt{164} = 12.8 \text{ N}$$

$$\tan \theta = \frac{8}{10}$$

$$\theta = 38.7^\circ$$

d

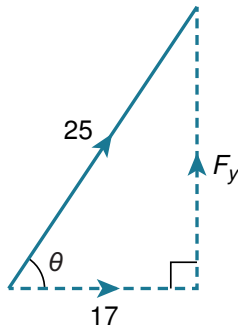

$$F_y^2 = 25^2 - 17^2 = 336$$

$$F_y = \sqrt{336} = 18.3 \text{ N (upwards)}$$

$$\cos \theta = \frac{17}{25}$$

$$\theta = 47.2^\circ$$

e

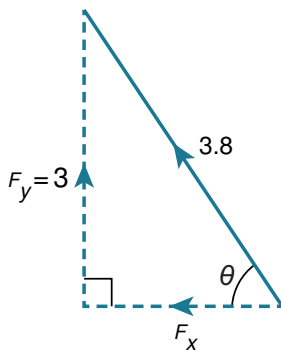

$$F_x^2 = 3.8^2 - 3^2 = 5.44$$

$$F_x = \sqrt{5.44} = 2.33 \text{ N (left)}$$

$$\sin \theta = \frac{3}{3.8}$$

$$\theta = 52.1^\circ$$

You must always indicate, clearly, the direction in which you are resolving forces. A simple arrow can be used to indicate 'vertical' or 'horizontal' directions, as in the following solutions.

$$3 \rightarrow F \cos \theta + 6 \cos 70^\circ = 5$$

$$F \cos \theta = 5 - 6 \cos 70^\circ$$

$$\uparrow F \sin \theta = 6 \sin 70^\circ$$

$$\tan \theta = \frac{6 \sin 70^\circ}{5 - 6 \cos 70^\circ}$$

$$\theta = 62.4^\circ$$

$$F^2 = (5 - 6 \cos 70^\circ)^2 + (6 \sin 70^\circ)^2$$

$$F = \sqrt{(5 - 6 \cos 70^\circ)^2 + (6 \sin 70^\circ)^2} = 6.36 \text{ N}$$

4

When you consider tensions acting on an object, remember that the forces act away from the object.

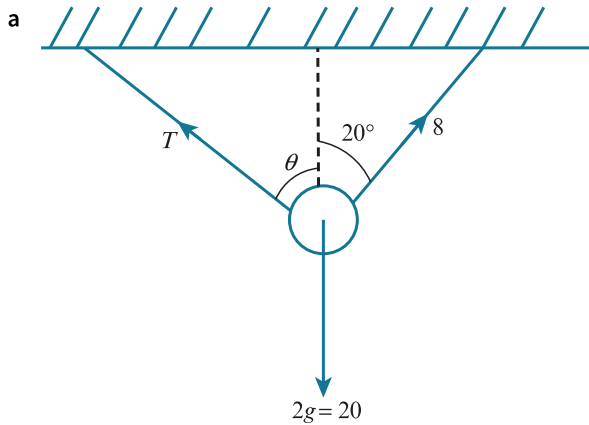

b

$$\leftarrow T \sin \theta = 8 \sin 20^\circ = 2.74$$

$$\uparrow T \cos \theta + 8 \cos 20^\circ = 20$$

$$T \cos \theta = 20 - 8 \cos 20^\circ = 12.5$$

c

$$\leftarrow T \sin \theta = 8 \sin 20^\circ$$

$$\uparrow T \cos \theta = 20 - 8 \cos 20^\circ$$

$$\tan \theta = \frac{8 \sin 20^\circ}{20 - 8 \cos 20^\circ}$$

$$\theta = 12.4^\circ$$

$$T^2 = (8 \sin 20^\circ)^2 + (20 - 8 \cos 20^\circ)^2$$

$$T = \sqrt{(8 \sin 20^\circ)^2 + (20 - 8 \cos 20^\circ)^2} = 12.8 \text{ N}$$

5

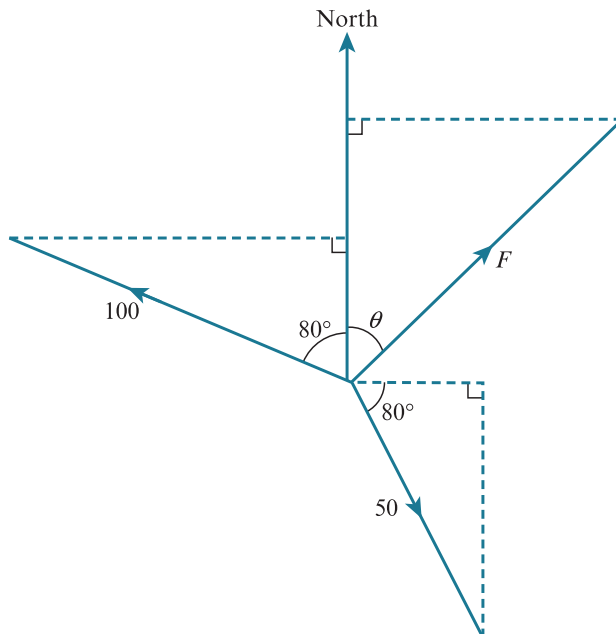

$$\rightarrow F \sin \theta + 50 \cos 80^\circ = 100 \sin 80^\circ$$

$$F \sin \theta = 100 \sin 80^\circ - 50 \cos 80^\circ$$

$$\uparrow F \cos \theta + 100 \cos 80^\circ = 50 \sin 80^\circ$$

$$F \cos \theta = 50 \sin 80^\circ - 100 \cos 80^\circ$$

$$\tan \theta = \frac{100 \sin 80^\circ - 50 \cos 80^\circ}{50 \sin 80^\circ - 100 \cos 80^\circ}$$

$$\theta = 70.5^\circ$$

bearing = 071°

$$F^2 = (100 \sin 80^\circ - 50 \cos 80^\circ)^2 + (50 \sin 80^\circ - 100 \cos 80^\circ)^2$$

$$F^2 = 9079.799$$

$$F = 95.3 \text{ N}$$

Multiple stage calculations can often be handled by newer calculators, in one go. If your calculator can't do this, use the memory functions to store parts of each calculation, so that you can recall more accurate values later on.

6 a

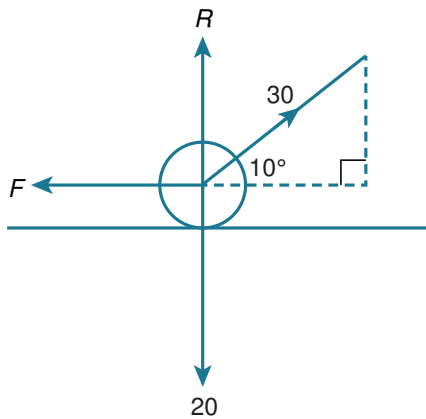

$$\text{b } \rightarrow \quad 30 \cos 10^\circ = F$$

$$F = 29.5 \text{ N}$$

$$\uparrow \quad R + 30 \sin 10^\circ = 20$$

$$R = 20 - 30 \sin 10^\circ$$

$$R = 14.8 \text{ N}$$

7

Double arrows on diagrams usually indicate an acceleration.

a

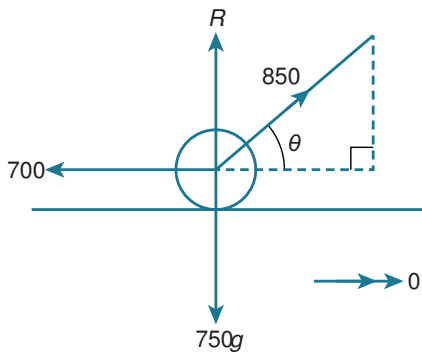

$$\text{b } \rightarrow \quad 850 \cos \theta = 700$$

$$\cos \theta = \frac{700}{850}$$

$$\theta = 34.6^\circ$$

$$\uparrow \quad R + 850 \sin \theta = 7500$$

$$R = 7500 - 850 \sin \theta$$

$$R = 7020 \text{ N}$$

8 a

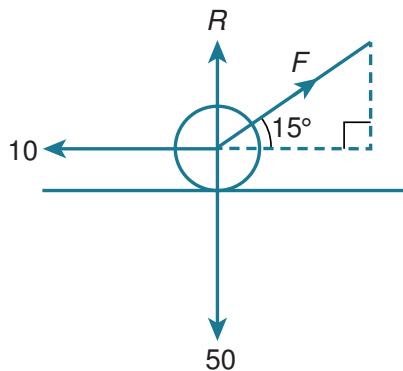

$$\begin{aligned} \text{b } \rightarrow \quad F \cos 15^\circ &= 10 \\ F &= \frac{10}{\cos 15^\circ} = 10.4 \text{ N} \\ \uparrow R + F \sin 15^\circ &= 50 \\ R &= 50 - F \sin 15^\circ \\ R &= 47.3 \text{ N} \end{aligned}$$

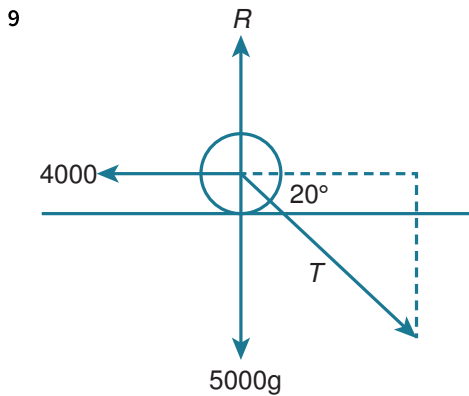

$$\begin{aligned} \rightarrow T \cos 20^\circ &= 4000 \\ T &= \frac{4000}{\cos 20^\circ} = 4260 \text{ N} \\ \uparrow R &= 5000g + T \sin 20^\circ = 51500 \text{ N} \end{aligned}$$

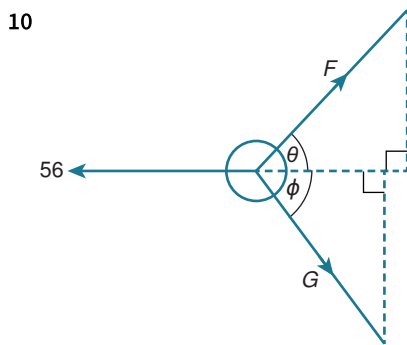

$$\sin \theta = \frac{3}{5}$$

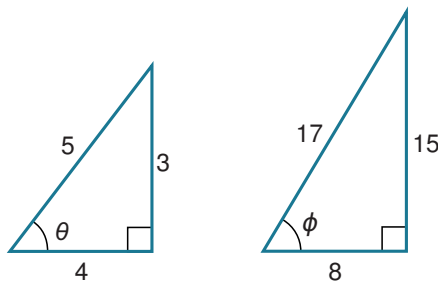

$$\begin{aligned} \cos \theta &= \frac{4}{5} \\ \sin \phi &= \frac{15}{17} \end{aligned}$$

You must use an accurate method to convert between sines and cosines. Whilst it is possible to find the angle and then calculate the required sine or cosine you will usually introduce decimals by doing this. Accuracy will then be reduced and you will not be able to give an exact answer quite so easily (or at all)!

$$\begin{aligned} \cos \phi &= \frac{8}{17} \\ \uparrow F \sin \theta &= G \sin \phi \\ \frac{3}{5} F &= \frac{15}{17} G \\ F &= \frac{25G}{17} \end{aligned}$$

$$\begin{aligned} \rightarrow F \cos \theta + G \cos \phi &= 56 \\ \frac{4}{5}F + \frac{8}{17}G &= 56 \\ \frac{4}{5} \left(\frac{25}{17}G \right) + \frac{8}{17}G &= 56 \\ \frac{20}{17}G + \frac{8}{17}G &= 56 \\ \frac{28}{17}G &= 56 \\ G &= 34 \text{ N} \\ F &= \frac{25}{17} \times 34 = 50 \text{ N} \end{aligned}$$

$$11 \sin \theta_1 = \frac{15}{17} \quad \sin \theta_2 = \frac{5}{13}$$

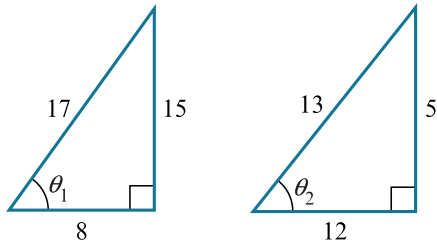

$$\cos \theta_1 = \frac{8}{17}$$

$$\cos \theta_2 = \frac{12}{13}$$

$$\rightarrow T_1 \sin \theta_1 = T_2 \sin \theta_2$$

$$\frac{15}{17}T_1 = \frac{5}{13}T_2$$

$$T_1 = \frac{17}{39}T_2$$

$$\uparrow T_1 \cos \theta_1 + T_2 \cos \theta_2 = 44$$

$$\frac{8}{17}T_1 + \frac{12}{13}T_2 = 44$$

$$\frac{8}{17} \left(\frac{17}{39} \right) T_2 + \frac{12}{13}T_2 = 44$$

$$\frac{8}{39}T_2 + \frac{36}{39}T_2 = 44$$

$$\frac{44}{39}T_2 = 44$$

$$T_2 = 39 \text{ N}$$

$$T_1 = \frac{17}{39} \times 39 = 17 \text{ N}$$

12

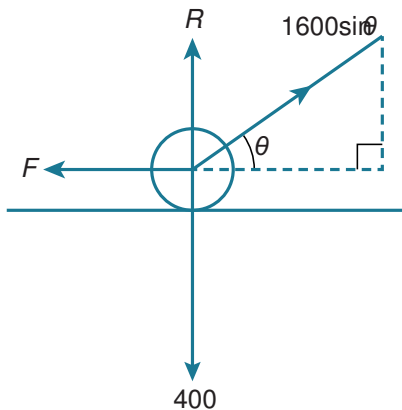

The object leaves the ground when the normal contact force becomes zero.

$$\uparrow R + 1600 \sin \theta (\sin \theta) = 400$$

$$R = 0$$

$$1600 \sin^2 \theta = 400$$

$$\sin^2 \theta = \frac{1}{4}$$

$$\sin \theta = \frac{1}{2}$$

$$\theta = 30^\circ$$

At this point, the horizontal force produced by the man trying to move the box is

$$1600 \sin \theta \cos \theta = 1600 \left(\frac{1}{2}\right) \left(\frac{\sqrt{3}}{2}\right) = 693 \text{ N} < 700 \text{ N}$$

The man has not produced enough force to move the box before it starts to lift, so it will lift before it slides.

$$13 \sin \theta = \frac{3}{5}$$

$$\cos \theta = \frac{4}{5}$$

$$\rightarrow F \cos \theta + G \cos \theta = 240 \cos 30^\circ$$

$$\frac{4}{5}(F + G) = \frac{240\sqrt{3}}{2}$$

$$F + G = 120\sqrt{3} \left(\frac{5}{4}\right)$$

$$F + G = 150\sqrt{3} \dots\dots\dots [1]$$

$$\uparrow F \sin \theta + 240 \sin 30^\circ = G \sin \theta$$

$$\frac{3}{5}F + 120 = \frac{3}{5}G$$

$$\frac{3}{5}(F - G) = -120$$

$$F - G = -200 \dots\dots\dots [2]$$

Adding [1] + [2]

$$2F = 150\sqrt{3} - 200$$

$$F = 75\sqrt{3} - 100$$

Subtracting [1] - [2]

$$2G = 150\sqrt{3} + 200$$

$$G = 75\sqrt{3} + 100$$

$$14 \uparrow 15 \sin \alpha = 13 \sin \beta$$

$$\rightarrow 15 \cos \alpha + 13 \cos \beta = 14$$

$$15 \cos \alpha = 14 - 13 \cos \beta$$

$$\cos \alpha = \frac{14 - 13 \cos \beta}{15}$$

$$\sin \alpha = \frac{13 \sin \beta}{15}$$

But $\sin^2 \alpha + \cos^2 \alpha = 1$

$$\left(\frac{13}{15} \sin \beta\right)^2 + \left(\frac{14 - 13 \cos \beta}{15}\right)^2 = 1$$

$$\frac{169}{225} \sin^2 \beta + \frac{196}{225} - \frac{364}{225} \cos \beta + \frac{169}{225} \cos^2 \beta = 1$$

$$169(\sin^2 \beta + \cos^2 \beta) - 29 = 364 \cos \beta$$

$$169 - 29 = 364 \cos \beta$$

$$\cos \beta = \frac{140}{364} \Rightarrow \beta = 67.4^\circ$$

$$\cos \alpha = \frac{14 - 13 \left(\frac{140}{364}\right)}{15} = 0.6$$

$$\alpha = 53.1^\circ$$

You will often find you need to use identities from Pure 1 trigonometry to solve Mechanics problems.

EXERCISE 3B

1

Try to redraw the diagram so that you can see all right-angled triangles clearly. It is completely fine to rotate the triangle.

a $150 \cos 35^\circ = 123 \text{ N}$ in the given direction.

b $14 \cos 25^\circ = 12.7 \text{ N}$ in the given direction.

c

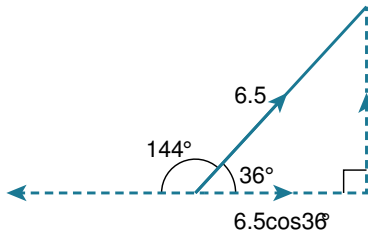

$6.5 \cos 36^\circ = 5.26 \text{ N}$ in opposite direction.

d

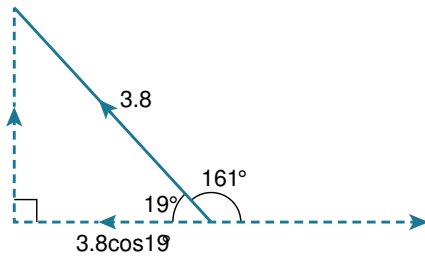

$3.8 \cos 19^\circ = 3.59 \text{ N}$ in opposite direction.

2 a

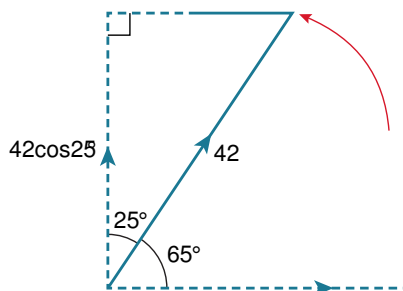

$42 \cos 25^\circ = 38.1 \text{ N}$ anticlockwise

b

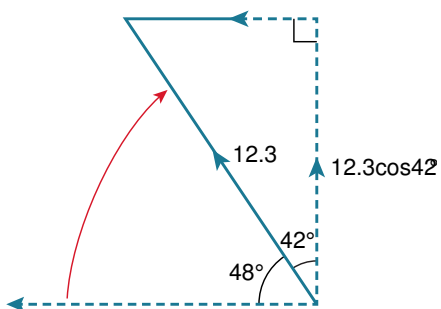

$12.3 \cos 42^\circ = 9.14 \text{ N}$ clockwise

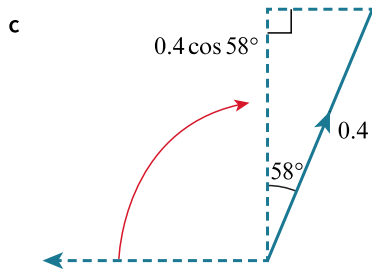

$$0.4 \cos 58^\circ = 0.212 \text{ N clockwise}$$

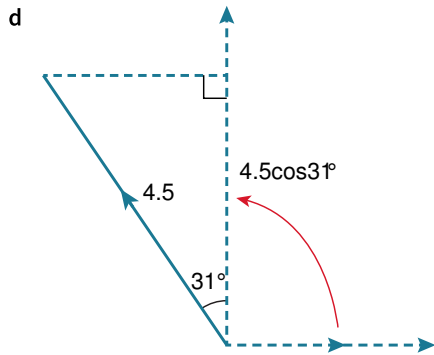

$$4.5 \cos 31^\circ = 3.86 \text{ N anticlockwise}$$

3

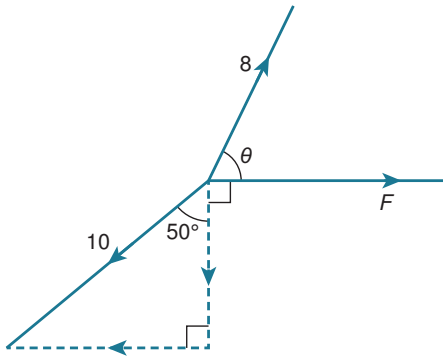

Sometimes it is enough to simply draw an arrow to indicate direction. If there are lots of lines pointing in roughly the same direction, however, you may need to state the direction clearly.

Perpendicular to F

$$\uparrow 8 \sin \theta = 10 \cos 50^\circ$$

$$\sin \theta = \frac{10 \cos 50^\circ}{8} \Rightarrow \theta = 53.5^\circ$$

Parallel to F

$$\rightarrow 8 \cos \theta + F = 10 \sin 50^\circ$$

$$F = 10 \sin 50^\circ - 8 \cos \theta = 2.90 \text{ N}$$

4

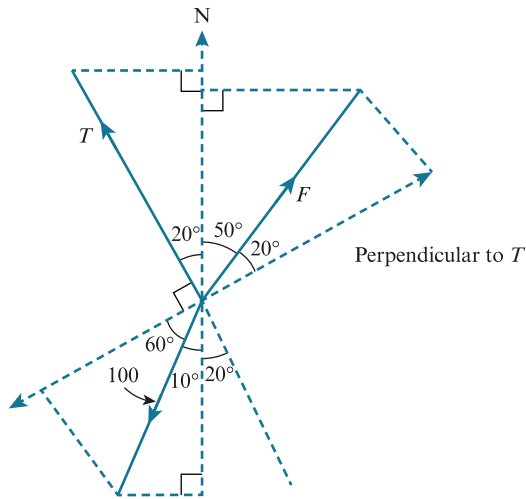

When the diagram includes several forces, it is particularly important that all lines that are NOT resultant forces are light and dotted. This is the only way to avoid confusion.

Perpendicular to T

$$\nearrow F \cos 20^\circ = 100 \cos 60^\circ$$

$$F = \frac{50}{\cos 20^\circ} = 53.2 \text{ N}$$

Parallel to T

$$\nwarrow T + F \sin 20^\circ = 100 \cos 30^\circ$$

$$T = 100 \cos 30^\circ - F \sin 20^\circ = 68.4 \text{ N}$$

5

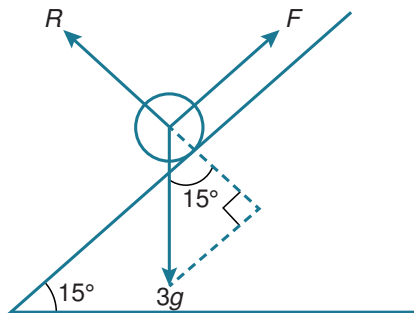

$$\nwarrow R = 3g \cos 15^\circ = 29.0 \text{ N}$$

$$\nearrow F = 3g \sin 15^\circ = 7.76 \text{ N}$$

6

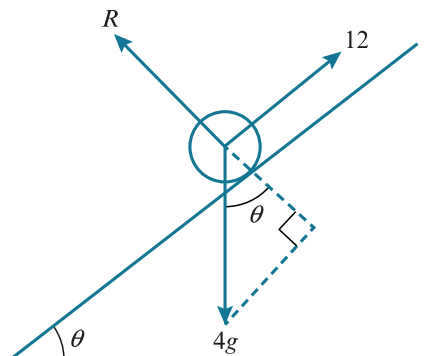

$$\nwarrow R = 4g \cos \theta$$

$$\nearrow 12 = 4g \sin \theta$$

$$\sin \theta = \frac{12}{4g} \Rightarrow \theta = 17.5^\circ$$

$$R = 4g \cos \theta = 38.2 \text{ N}$$

7

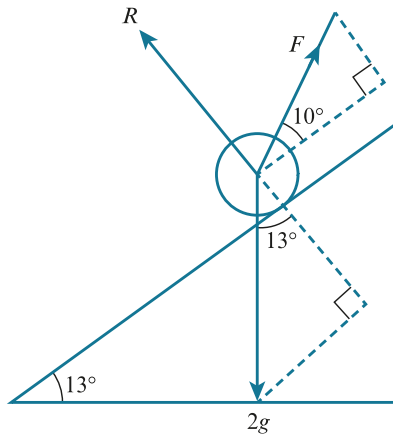

$$\nearrow F \cos 10^\circ = 2g \sin 13^\circ$$

$$F = \frac{2g \sin 13^\circ}{\cos 10^\circ} = 4.57 \text{ N}$$

$$\nwarrow R + F \sin 10^\circ = 2g \cos 13^\circ$$

$$R = 2g \cos 13^\circ - F \sin 10^\circ$$

$$R = 18.7 \text{ N}$$

8

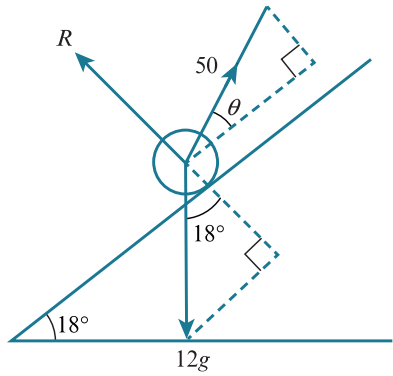

$$\nearrow 50 \cos \theta = 12g \sin 18^\circ$$

$$\cos \theta = \frac{120 \sin 18^\circ}{50} \Rightarrow \theta = 42.1^\circ$$

$$\nwarrow R + 50 \sin \theta = 12g \cos 18^\circ$$

$$R = 120 \cos 18^\circ - 50 \sin \theta$$

$$R = 80.6 \text{ N}$$

9

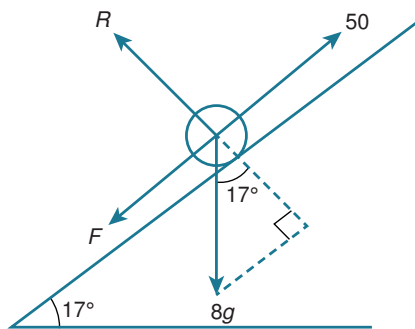

$$\nearrow 50 = F + 8g \sin 17^\circ$$

$$F = 50 - 80 \sin 17^\circ = 26.6 \text{ N}$$

$$\nwarrow R = 8g \cos 17^\circ = 76.5 \text{ N}$$

10

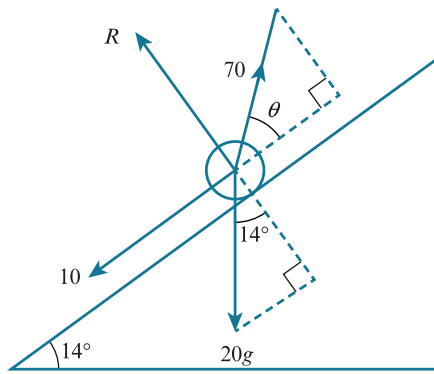

$$\begin{aligned} \nearrow 70 \cos \theta &= 20g \sin 14^\circ + 10 \\ \cos \theta &= \frac{20g \sin 14^\circ + 10}{70} \Rightarrow \theta = 33.5^\circ \\ \nwarrow R &= 20g \cos 14^\circ - 70 \sin \theta = 155 \text{ N} \end{aligned}$$

11

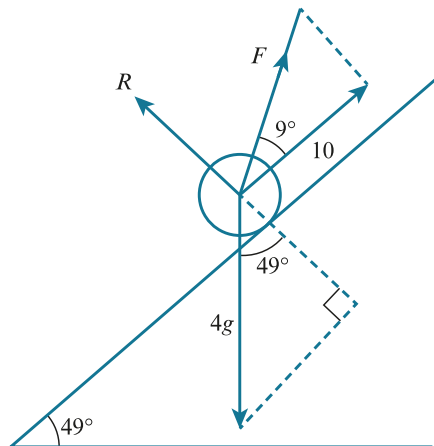

$$\begin{aligned} \nearrow F \cos 9^\circ + 10 &= 4g \sin 49^\circ \\ F &= \frac{40 \sin 49^\circ - 10}{\cos 9^\circ} = 20.4 \text{ N} \\ \nwarrow R + F \sin 9^\circ &= 40 \cos 49^\circ \\ R &= 40 \cos 49^\circ - F \sin 9^\circ = 23.0 \text{ N} \end{aligned}$$

12

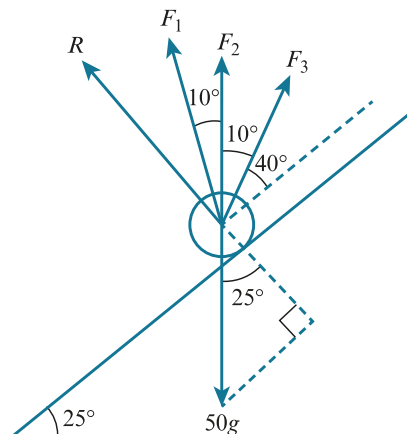

a

When working on questions like this you will need to look at lots of different cases before you can work out the best possible answer. Try to create a general formula and substitute the values for each case instead of re-writing everything over and over.

$$\nearrow F_1 \cos 60^\circ + F_2 \cos 50^\circ + F_3 \cos 40^\circ = 50g \sin 25^\circ$$

If the man pulls with 170 N and the boys pull with force P :

Man provides force F_1 :

$$170 \cos 60^\circ + P(\cos 50^\circ + \cos 40^\circ) = 50g \sin 25^\circ$$

$$P = 89.7 \text{ N} < 90 \text{ N (possible)}$$

Man provides force F_2 :

$$P(\cos 60^\circ + \cos 40^\circ) + 170 \cos 50^\circ = 50g \sin 25^\circ$$

$$P = 80.6 \text{ N} < 90 \text{ N (possible)}$$

Man provides force F_3 :

$$P(\cos 60^\circ + \cos 50^\circ) + 170 \cos 40^\circ = 50g \sin 25^\circ$$

$$P = 71.0 \text{ N} < 90 \text{ (possible)}$$

b $\nearrow F_1 \cos 60^\circ + F_2 \cos 50^\circ + F_3 \cos 40^\circ = 50g \sin 25^\circ$

If the man pulls with 180 N and the boys pull with force P :

Man provides force F_1 :

$$180 \cos 60^\circ + P(\cos 50^\circ + \cos 40^\circ) = 50g \sin 25^\circ$$

$$P = 86.1 \text{ N} > 70 \text{ N}$$

Man provides force F_2 :

$$P(\cos 60^\circ + \cos 40^\circ) + 180 \cos 50^\circ = 50g \sin 25^\circ$$

$$P = 75.5 \text{ N} > 70 \text{ N}$$

Man provides force F_3 :

$$P(\cos 60^\circ + \cos 50^\circ) + 180 \cos 40^\circ = 50g \sin 25^\circ$$

$$P = 64.2 \text{ N} < 70 \text{ N}$$

Only the last case is possible, so the man takes force F_3 , at 40° .

13

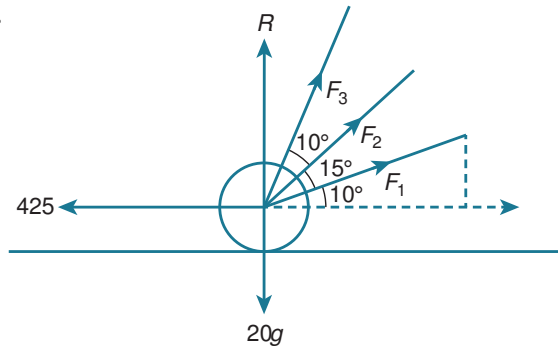

a If $F_1 = 250 \text{ N}$ and $F_2 = 200 \text{ N}$:

$$\rightarrow F_1 \cos 10^\circ + F_2 \cos 25^\circ = 250 \cos 10^\circ + 200 \cos 25^\circ$$

$$= 427 \text{ N} > 425 \text{ N}$$

So this is possible.

b To provide the greatest horizontal force, let $F_1 = 250 \text{ N}$, $F_2 = 200 \text{ N}$ and $F_3 = 150 \text{ N}$.

$$F_1 \cos 10^\circ + F_2 \cos 25^\circ + F_3 \cos 35^\circ$$

$$= 250 \cos 10^\circ + 200 \cos 25^\circ + 150 \cos 35^\circ$$

$$= 550.3 \text{ N} > 550$$

This is just about possible.

$$\text{But vertical force is now } 250 \sin 10^\circ + 200 \sin 25^\circ + 150 \sin 35^\circ = 214 > 200 \text{ N}$$

It cannot stay on the ground.

E EXERCISE 3C

1

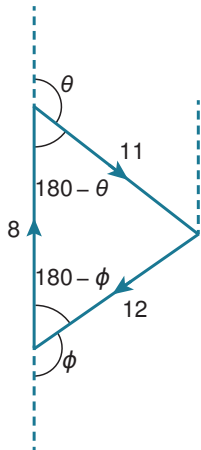

Make sure that you draw large and clear diagrams, so that all angles are clear. You may need to leave room to add more information later in each question. It is often the case, also, that you will need to extend the lines of action of forces so that you can draw the correct angles.

$$\cos(180^\circ - \phi) = \frac{8^2 + 12^2 - 11^2}{2(8)(12)} \Rightarrow \phi = 116.9^\circ$$

$$\cos(180^\circ - \theta) = \frac{11^2 + 8^2 - 12^2}{2(11)(8)} \Rightarrow \theta = 103.5^\circ$$

2

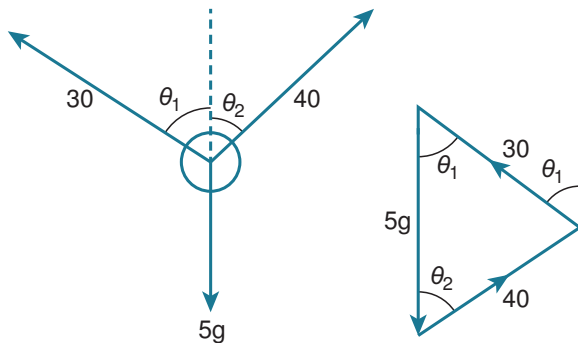

$$\cos \theta_1 = \frac{30^2 + (5g)^2 - 40^2}{2(30)(5g)} \Rightarrow \theta_1 = 53.1^\circ$$

$$\cos \theta_2 = \frac{50^2 + 40^2 - 30^2}{2(40)(50)} \Rightarrow \theta_2 = 36.9^\circ$$

So the 30 N force makes an angle of 53.1° to the vertical and the 40 N force makes an angle of 36.9° to the vertical.

3

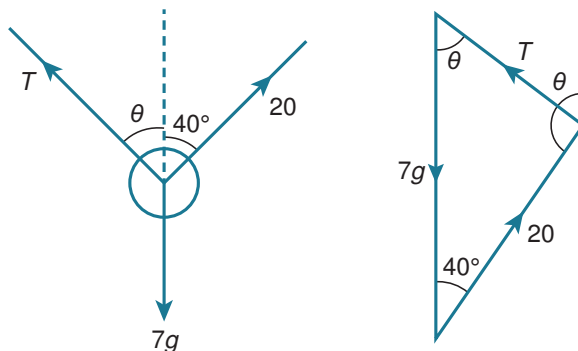

Do not try to use the cosine rule without drawing the appropriate triangles. Sometimes the angles are not quite what you expect them to be.

Cosine rule:

$$T^2 = (7g)^2 + 20^2 - 2(7g)(20) \cos 40^\circ$$

$$T = 56.2 \text{ N}$$

$$\frac{\sin \theta}{20} = \frac{\sin 40^\circ}{T} \Rightarrow \sin \theta = \frac{20 \sin 40^\circ}{T}$$

$$\theta = 13.2^\circ$$

4

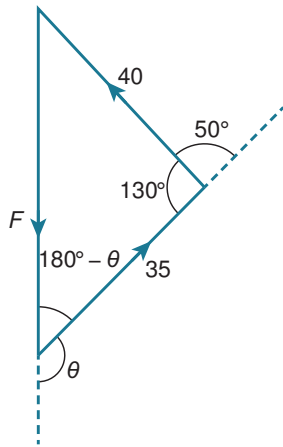

$$F^2 = 40^2 + 35^2 - 2(40)(35) \cos 130^\circ$$

$$F = 68.0 \text{ N}$$

$$\frac{\sin(180^\circ - \theta)}{40} = \frac{\sin 130^\circ}{F}$$

$$\sin(180^\circ - \theta) = \frac{40 \sin 130^\circ}{F} \Rightarrow \theta = 153.2^\circ$$

5

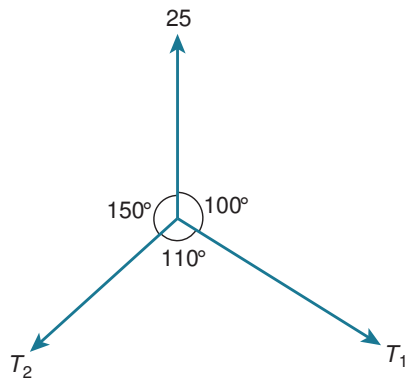

$$\frac{T_1}{\sin 150^\circ} = \frac{25}{\sin 110^\circ} \Rightarrow T_1 = 13.3 \text{ N}$$

$$\frac{T_2}{\sin 100^\circ} = \frac{25}{\sin 110^\circ} \Rightarrow T_2 = 26.2 \text{ N}$$

6

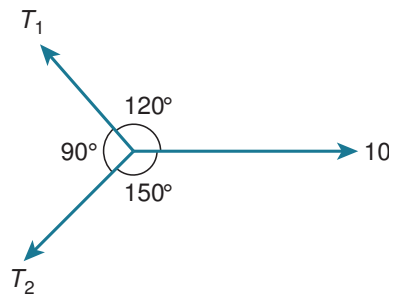

$$\frac{T_1}{\sin 150^\circ} = \frac{T_2}{\sin 120^\circ} = \frac{10}{\sin 90^\circ} = 10$$

$$T_1 = 10 \sin 150^\circ = 5 \text{ N}$$

$$T_2 = 10 \sin 120^\circ = 8.66 \text{ N}$$

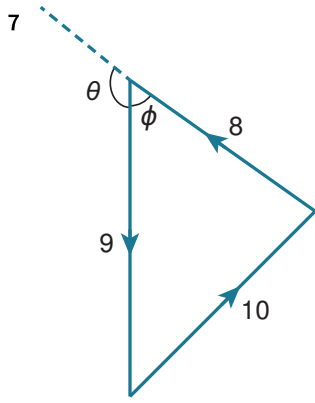

If you need to extend lines to help with angle calculations, you should always make sure that the extensions are faint and dotted so you don't confuse them with the lines in the triangle.

$$\cos \phi = \frac{9^2 + 8^2 - 10^2}{2(9)(8)} \Rightarrow \phi = 71.79^\circ$$

$$\theta = 180^\circ - \phi = 108.2^\circ$$

8 a

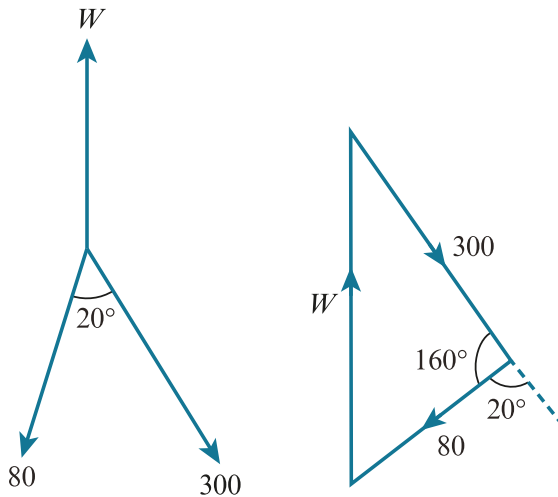

b $W^2 = 80^2 + 300^2 - 2(80)(300) \cos 160^\circ$
 $W = 376 \text{ N}$

c Assume that the child works with the wind. Then the adult needs to overcome $80 + W \text{ N}$. This works as long as

$$80 + W \leq 300$$

$$W \leq 220 \text{ N}$$

To gain maximum deviations, the child needs to pull in a direction perpendicular to the direction of travel.

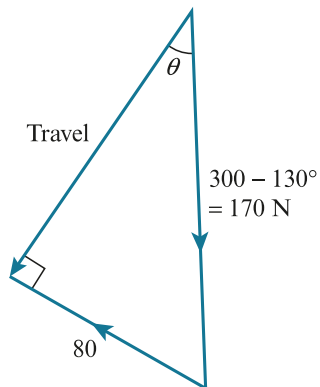

$$\sin \theta = \frac{80}{170} \Rightarrow \theta = 28.1^\circ$$

9

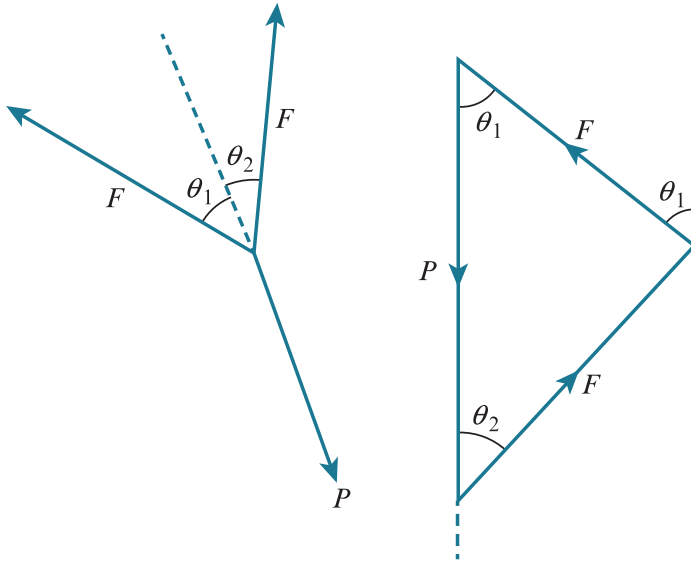

Triangle is isosceles, so $\theta_1 = \theta_2$

10

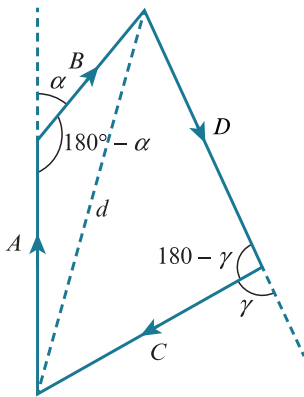

$$d^2 = A^2 + B^2 - 2AB \cos(180^\circ - \alpha)$$

Similarly

$$d^2 = C^2 + D^2 - 2CD \cos(180^\circ - \gamma)$$

$$A^2 + B^2 - 2AB \cos(180^\circ - \alpha) = d^2$$

$$= C^2 + D^2 - 2CD \cos(180^\circ - \gamma)$$

But

$$\cos(180^\circ - \alpha) = -\cos \alpha$$

$$\cos(180^\circ - \gamma) = -\cos \gamma$$

$$A^2 + B^2 + 2AB \cos \alpha = C^2 + D^2 + 2CD \cos \gamma$$

If you are unsure why $\cos(180^\circ - \theta) = -\cos \theta$, try drawing the graph of $y = \cos(180^\circ - \theta)$ and consider which transformations need to be applied to the $y = \cos \theta$ graph.

EXERCISE 3D

1 $\rightarrow a$

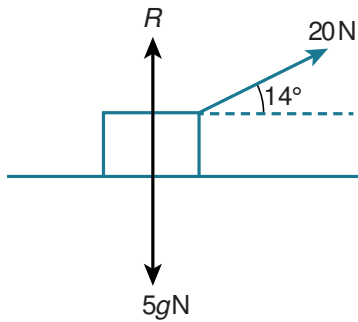

In previous exercises we have used arrows to indicate the direction for resolving forces. In this question the first arrow indicates the direction in which $F = ma$ has been applied. If there is no acceleration in the direction of the arrow, just equate opposing forces that are parallel to the arrow.

\rightarrow

$$20 \cos 14^\circ = 5a$$

$$a = 4 \cos 14^\circ = 3.88 \text{ m s}^{-2}$$

\uparrow

$$R + 20 \sin 14^\circ = 5g$$

$$R = 5g - 20 \sin 14^\circ = 45.2 \text{ N}$$

2 a

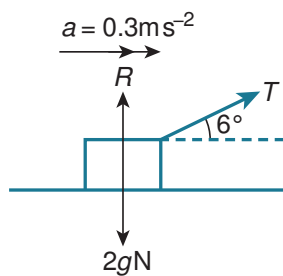

\rightarrow

$$\text{b } T \cos 6^\circ = 2(0.3)$$

$$T = \frac{0.6}{\cos 6^\circ} = 0.603 \text{ N}$$

\uparrow

$$R + T \sin 6^\circ = 2g$$

$$R = 2g - T \sin 6^\circ = 19.9 \text{ N}$$

3

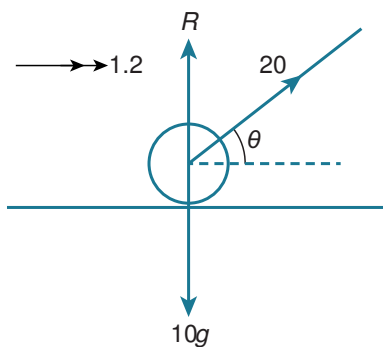

\rightarrow

$$20 \cos \theta = 10(1.2)$$

$$\cos \theta = \frac{12}{20}$$

$$\theta = 53.1^\circ$$

↑

$$R + 20 \sin \theta = 10g$$

$$R = 100 - 20 \sin \theta = 84 \text{ N}$$

4

Resolve perpendicular to direction of motion first because there is no net force in this direction.

↑

$$80 \sin 18^\circ = T \sin 25^\circ$$

$$T = \frac{80 \sin 18^\circ}{\sin 25^\circ} = 58.5 \text{ N}$$

→

$$80 \cos 18^\circ + T \cos 25^\circ = 1000a$$

$$a = \frac{80 \cos 18^\circ + 58.49 \dots \times \cos 25^\circ}{1000} = 0.129 \text{ m s}^{-2}$$

5

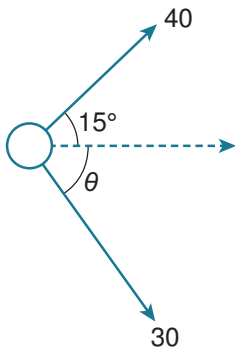

↑

$$40 \sin 15^\circ = 30 \sin \theta$$

$$\sin \theta = \frac{40 \sin 15^\circ}{30}$$

$$\theta = 20.2^\circ$$

→

$$40 \cos 15^\circ + 30 \cos \theta = 20a$$

$$a = \frac{40 \cos 15^\circ + 30 \cos \theta}{20} = 3.34 \text{ m s}^{-2}$$

6 a

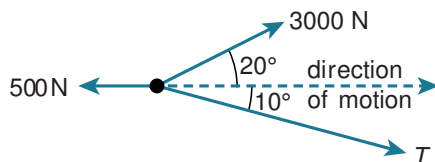

b ↑

$$3000 \sin 20^\circ = T \sin 10^\circ$$

$$T = \frac{3000 \sin 20^\circ}{\sin 10^\circ} = 5910 \text{ N}$$

→

$$3000 \cos 20^\circ + T \cos 10^\circ - 500 = 15000a$$

$$a = 0.543 \text{ m s}^{-2}$$

Notice that we continue to leave units out until we reach the end of a section of calculation. However, we never omit degrees symbols.

7

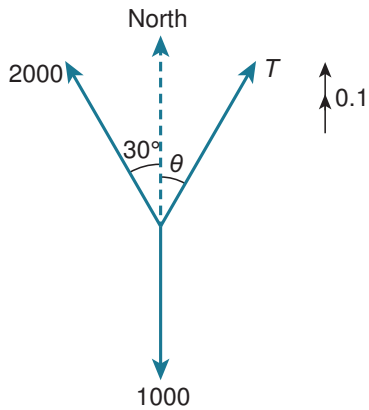

→

$$T \sin \theta = 2000 \sin 30^\circ = 1000 \dots\dots [1]$$

↑

$$T \cos \theta + 2000 \cos 30^\circ - 1000 = 1000(0.1)$$

$$T \cos \theta = 2000 - 2000 \cos 30^\circ \dots\dots [2]$$

[1]

[2]

$$\tan \theta = \frac{1000}{2000(1 - \cos 30^\circ)}$$

$$\theta = 75^\circ$$

[1]² + [2]²

$$T^2 = 1000^2 + (2000 - 2000 \cos 30^\circ)^2$$

$$T = 1040 \text{ N}$$

You will often need to resolve in perpendicular directions and combine the resulting equations. This usually means combining sines and cosines. When this happens you will often need to divide the equations before squaring and adding.

An alternative method would be to substitute your value for θ into equation [1] and solve to find T , but this will not give you an exact answer.

8

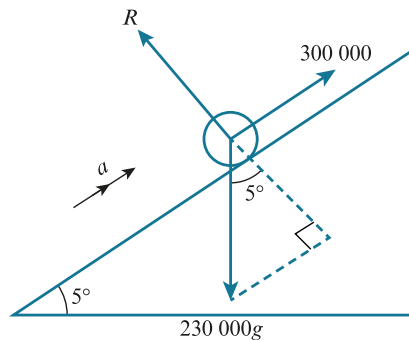

↗

$$300\,000 - 2\,300\,000 \sin 5^\circ = 230\,000a$$

$$a = 0.433 \text{ m s}^{-2}$$

9 a

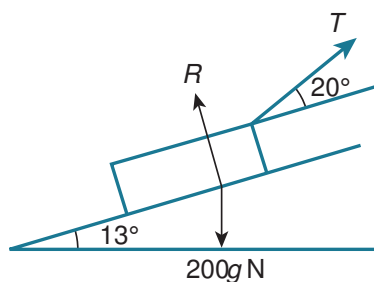

b $T \cos 20^\circ - 200g \sin 13^\circ = 200(0.3)$
 $T = \frac{60 + 2000 \sin 13^\circ}{\cos 20^\circ} = 543 \text{ N}$

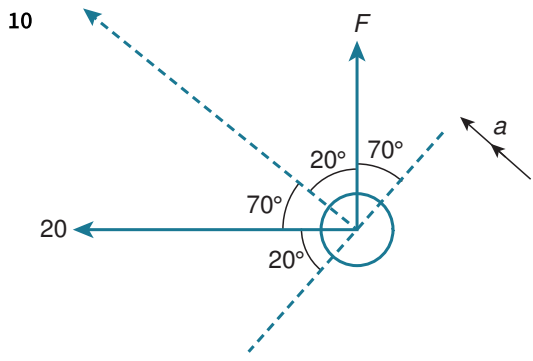

$F \cos 70^\circ = 20 \cos 20^\circ$
 $F = \frac{20 \cos 20^\circ}{\cos 70^\circ} = 54.9 \text{ N}$

$F \cos 20^\circ + 20 \cos 70^\circ = 80 a$
 $a = 0.731 \text{ m s}^{-2}$

11 You always maximise a change in direction by ‘pushing’ or ‘pulling’ perpendicular to the direction of motion.

Perpendicular to motion

$25 \sin 10^\circ = 15 \sin \theta$
 $\sin \theta = \frac{25 \sin 10^\circ}{15}$
 $\theta = 16.8^\circ$

$25 \cos 10^\circ + 15 \cos \theta = 12 a$
 $a = 3.25 \text{ m s}^{-2}$

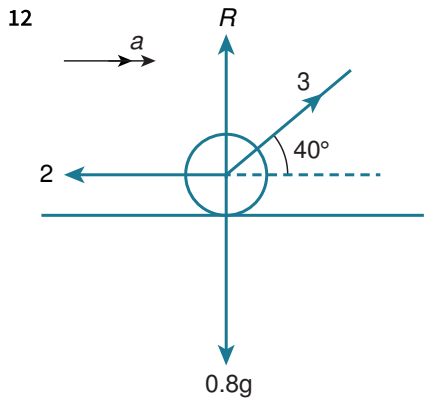

$3 \cos 40^\circ - 2 = 0.8 a$
 $a = 0.373 \text{ m s}^{-2}$

$u = 0, v = 2, a = 0.373, t = ?$

$v = u + at$

$t = \frac{v - u}{a} = \frac{2}{0.373} = 5.37 \text{ s}$

In many questions you will need to use Newton’s second law to find the acceleration and then use a constant acceleration equation to work out a speed, time or distance.

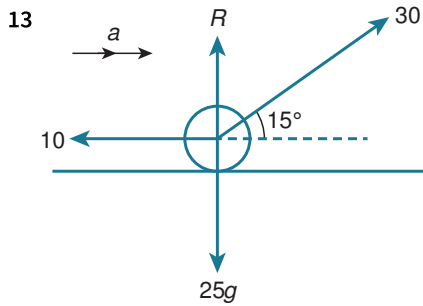

→

$$30 \cos 15^\circ - 10 = 25 a$$

$$a = 0.759 \text{ m s}^{-2}$$

$$u = 0, v = ? \quad a = 0.759, s = 6$$

$$v^2 = u^2 + 2as$$

$$v = \sqrt{0 + 2(0.759)(6)} = 3.02 \text{ m s}^{-1}$$

14 a

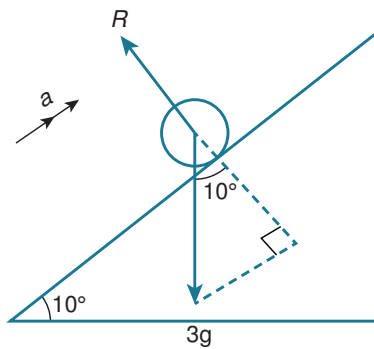

↗

$$F = ma$$

$$-3g \sin 10^\circ = 3 a$$

$$a = -g \sin 10^\circ$$

$$u = 4, v = 0, a = -g \sin 10^\circ, s = ?$$

$$v^2 = u^2 + 2as$$

$$s = \frac{v^2 - u^2}{2a} = \frac{0 - 4^2}{-2g \sin 10^\circ} = 4.61 \text{ m}$$

b The ball is modelled as a particle.

There is no air resistance or friction.

The ball moves straight up the slope.

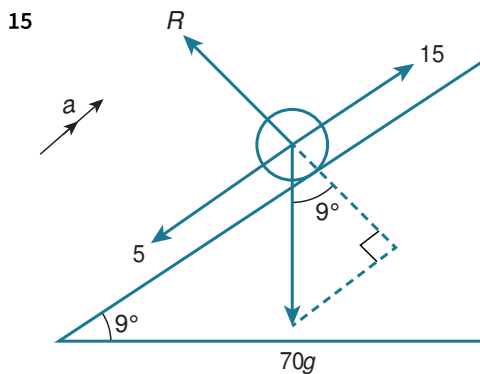

↗

$$15 - 5 - 70 g \sin 9^\circ = 70 a$$

$$a = -1.42 \text{ m s}^{-2}$$

$$s = 30, u = 10, a = -1.42, t = ?$$

$$s = ut + \frac{1}{2}at^2$$

$$30 = 10t - 0.711t^2$$

$$0.711t^2 - 10t + 30 = 0$$

$$t = 4.34 \text{ or } t = 9.73 \text{ s}$$

$t = 4.34 \text{ s}$ is the first relevant time

16

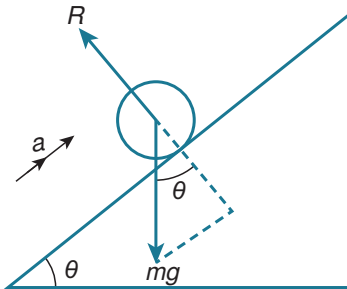

↗

$$-mg \sin \theta = ma$$

$$a = -g \sin \theta = -\frac{2}{5}g = -4 \text{ m s}^{-2}$$

$$s = 5, u = 7, a = -4, t = ?$$

$$s = ut + \frac{1}{2}at^2$$

$$5 = 7t - 2t^2$$

$$2t^2 - 7t + 5 = 0$$

$$(2t - 5)(t - 1) = 0$$

$$t = 1 \text{ or } t = \frac{5}{2}$$

The ball is at B at $t = 1$ and $t = 2.5$ so the time between passing B on the way up and down is 1.5 s.

17

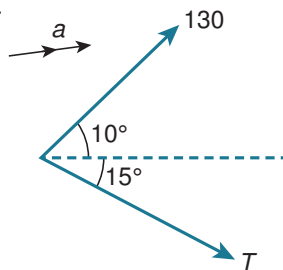

↑

$$T \sin 15^\circ = 130 \sin 10^\circ$$

$$T = \frac{130 \sin 10^\circ}{\sin 15^\circ}$$

→

$$130 \cos 10^\circ + T \cos 15^\circ = 2000a$$

$$a = \frac{130 \cos 10^\circ + \frac{130 \sin 10^\circ}{\sin 15^\circ} (\cos 15^\circ)}{2000} = 0.106 \text{ m s}^{-2}$$

$$u = 0, s = ? a = 0.106 \dots, t = 10$$

$$s = ut + \frac{1}{2}at^2$$

$$= 0 + \frac{1}{2}a \times 10^2 = 50a = 5.31 \text{ m}$$

18

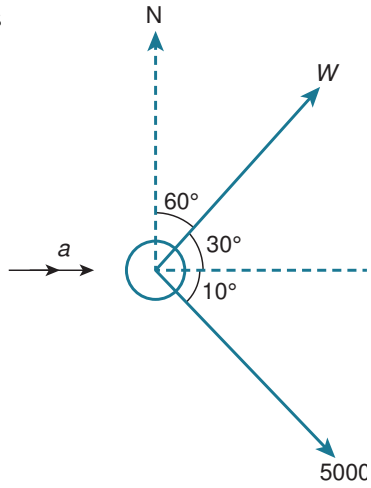

↑

$$5000 \sin 10^\circ = T \sin 30^\circ$$

$$T = 1736$$

→

$$5000 \cos 10^\circ + T \cos 30^\circ = 15000 a$$

$$a = 0.429 \text{ m s}^{-2}$$

$$v = u + at$$

$$v = 2 + 5 \times 0.429 = 4.14 \text{ m s}^{-1}$$

19

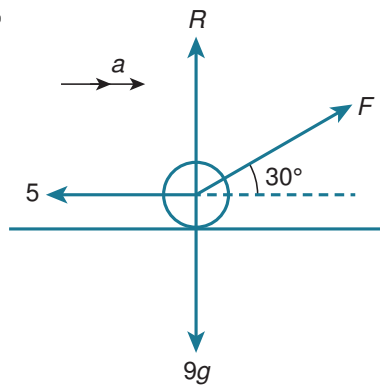

$$u = 0, v = 4, s = 10, a = ?$$

$$v^2 = u^2 + 2as$$

$$a = \frac{v^2 - u^2}{2s} = \frac{4^2 - 0^2}{2(10)} = \frac{4}{5}$$

→

$$F \cos 30^\circ - 5 = 9a$$

$$F = \frac{9a + 5}{\cos 30^\circ} = 14.1 \text{ N}$$

In this question you need to use the constant acceleration equation first to find a and then use Newton's second law to find the friction force.

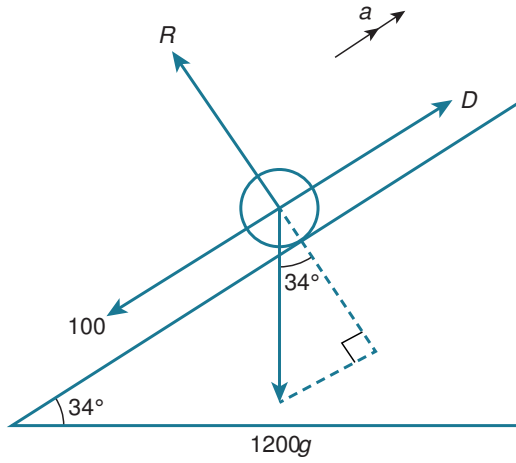

If the minimum force is applied then the car will only just make it to the top of the slope. The car stops at the top of the slope.

$$v = 0, u = 12, a = ? s = 130$$

$$v^2 = u^2 + 2as$$

$$a = \frac{v^2 - u^2}{2s} = \frac{-12^2}{2(130)} = -0.5538\dots$$

↗

$$D - 100 - 1200g \sin 34^\circ = 1200a$$

$$D = 1200a + 100 + 1200g \sin 34^\circ = 6150 \text{ N}$$

EXERCISE 3E

$$1 \quad R^2 = 3^2 + 5^2 = 34$$

$$R = \sqrt{34} = 5.83 \text{ N}$$

$$\nearrow F = ma$$

$$\sqrt{34} = 3a$$

$$a = \frac{\sqrt{34}}{3} = 1.94 \text{ m s}^{-2}$$

$$\tan \theta = \frac{5}{3}$$

$$\theta = 59.0^\circ$$

i.e. 31.0° to the right of the positive y-direction.

If the question is about a real-world example, then use the features of the situation to describe directions. For example, 'up the line of greatest slope', 'perpendicular to the slope' or 'in the direction of motion'.

2

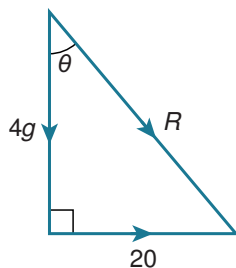

$$\tan \theta = \frac{20}{4g} = \frac{1}{2}$$

$$\theta = 26.6^\circ$$

3

This solution to Question 3 uses the sine rule, but you can also resolve vertically and horizontally, and use a right-angled triangle. Try it!

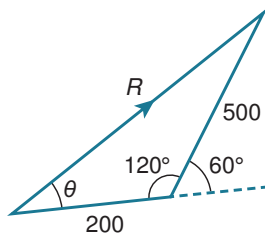

$$R^2 = 500^2 + 200^2 - 2(500)(200) \cos 120^\circ$$

$$R = \sqrt{390000} = 624.499 \dots$$

$$\frac{\sin \theta}{500} = \frac{\sin 120^\circ}{R}$$

$$\sin \theta = \frac{500 \sin 120^\circ}{R}$$

$\theta = 43.9^\circ$ above the positive x -direction.

Sometimes you need to calculate one answer and use it to get another. If this happens make sure that you round answers as little as possible until the very end. Use the memory function on your calculator if necessary.

4

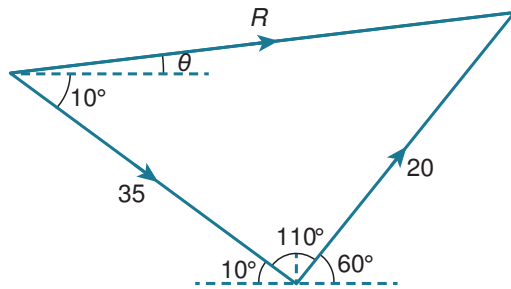

$$R^2 = 35^2 + 20^2 - 2(35)(20) \cos 110^\circ$$

$$R = 45.8675 \dots$$

$$R = ma$$

$$a = \frac{R}{25} = 1.83 \text{ m s}^{-2}$$

$$\frac{\sin(10 + \theta)}{20} = \frac{\sin 110^\circ}{R}$$

$$\sin(10 + \theta) = \frac{20 \sin 110^\circ}{R}$$

$\theta = 14.2^\circ$ above the positive x -direction.

5 \rightarrow

$$0 + 25 - 10 = 15 \text{ N}$$

 \uparrow

$$20 - 10 - 15 = -5 \text{ N}$$

$$R^2 = 5^2 + 15^2$$

$$= 25 + 225 = 250$$

$$R = \sqrt{250} = 15.8 \text{ N}$$

$$\tan \theta = \frac{5}{15}$$

$\theta = 18.4^\circ$ below the positive x -direction.

It is essential that you describe the direction from which angles are measured carefully. The same direction makes two very different angles from the positive and negative x -directions, so you can't just write 'the angle with the x -direction', because this is an ambiguous statement.

6 a $\tan \alpha = \frac{40}{30}$
 $\alpha = 53.1^\circ$

b \uparrow

$$40 - 40 - 30 \sin 30^\circ$$

$$= 0 - \frac{30}{2} = -15 \text{ N}$$

 \rightarrow

$$30 \cos 30^\circ - 30 = -4.019 \dots$$

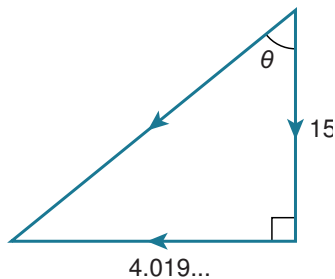

Resultant

$$= \sqrt{4.019^2 + 15^2}$$

$$= 15.5 \text{ N}$$

$$\tan \theta = \frac{4.019 \dots}{15}$$

$\theta = 15^\circ$ with vertical

75° below the negative x -direction.

7 \uparrow

$$40 - 60 \sin 30^\circ - 20 \sin 60^\circ - 40 \sin 60^\circ \\ = 10 - 30\sqrt{3}$$

\rightarrow

$$40 \cos 60^\circ - 20 \cos 60^\circ - 60 \cos 30^\circ \\ = 10 - 30\sqrt{3}$$

The two forces are the same, so the resultant makes 45° with the x -direction. Both forces are negative, so the angle is 45° with the negative x -direction.

8 a \uparrow

$$40 \cos 10^\circ + 25 \cos 40^\circ + 35 \cos 60^\circ$$

\rightarrow

$$40 \sin 10^\circ + 25 \sin 40^\circ + 35 \sin 60^\circ$$

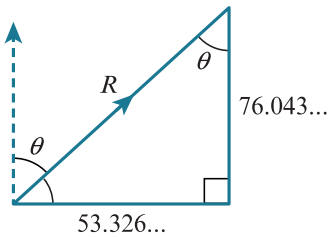

$$R = \sqrt{76.043 \dots^2 + 53.326 \dots^2} = 92.9 \text{ N}$$

$$F = ma$$

$$R = 150 a$$

$$a = 0.619 \text{ m s}^{-2}$$

$$\tan \theta = \frac{53.326 \dots}{76.043 \dots}$$

$$\theta = 35.0^\circ \text{ with the direction } AB.$$

b The people continue to pull at these angles once the motion starts, otherwise the answer will only be in the initial direction of motion.

9 500

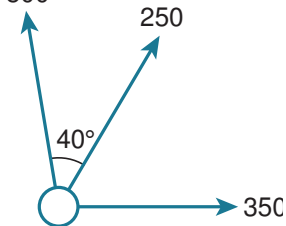

\uparrow

$$500 + 250 \cos 40^\circ$$

\rightarrow

$$350 + 250 \sin 40^\circ$$

Remember to avoid using decimals where possible. Sometimes it is difficult to manage this, at which point you need to make sure that you record several decimal places.

$$\tan \theta = \frac{350 + 250 \sin 40^\circ}{500 + 250 \cos 40^\circ}$$

$$\theta = 36.4^\circ = \text{bearing}$$

$$R^2 = (350 + 250 \sin 40^\circ)^2 + (500 + 250 \cos 40^\circ)^2$$

$$R = 860 \text{ N}$$

$$F = ma$$

$$R = 1000 a$$

$$a = 0.860 \text{ m s}^{-2}$$

10 ↑

$$330 \cos 10^\circ + 250 \sin 5^\circ - 280 \sin 10^\circ - 300 \cos 10^\circ = 2.712 \text{ N}$$

→

$$330 \sin 10^\circ + 250 \cos 5^\circ + 300 \sin 10^\circ - 280 \cos 10^\circ = 82.7008 \dots \text{ N}$$

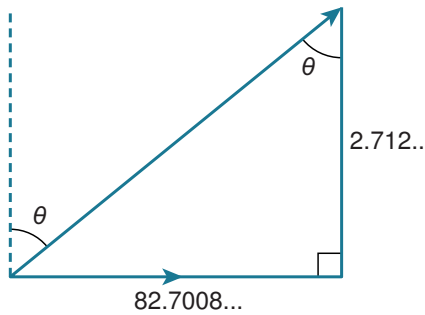

$$\tan \theta = \frac{82.7 \dots}{2.7 \dots}$$

$$\theta = 88.1^\circ$$

Closest to Bob. So Bob wins.

11

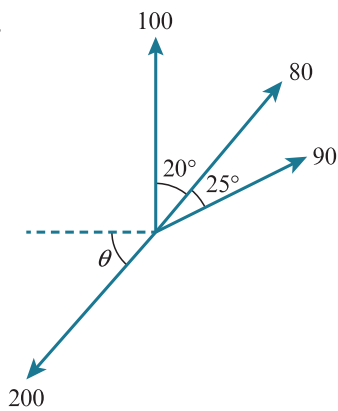

Force exerted by boats:

↑

$$100 + 80 \cos 20^\circ + 90 \cos 45^\circ = 238.815 \dots$$

→

$$80 \sin 20^\circ + 90 \sin 45^\circ = 91.00122 \dots$$

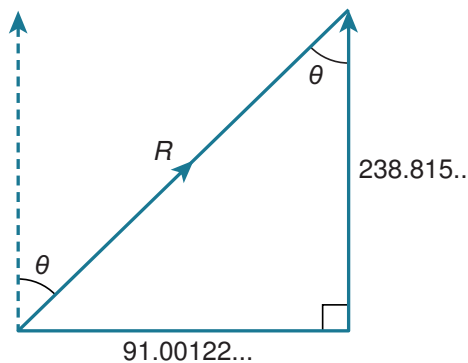

$$R = \sqrt{238.815 \dots^2 + 91.00122 \dots^2} = 255.6$$

$$\text{Overall force} = R - 200 = 55.6 \dots$$

$$F = ma$$

$$a = \frac{R - 55.6 \dots}{120} = 0.463 \text{ m s}^{-2}$$

$$\tan \theta = \frac{91.00122 \dots}{238.815 \dots}$$

$$\theta = 21^\circ$$

12

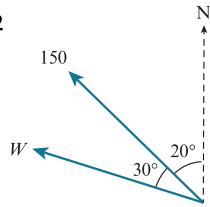

We know that the resultant force makes an acute angle of 40° with the north line. If we now resolve into north and west components, we can draw a right-angled triangle to show the 40° angle.

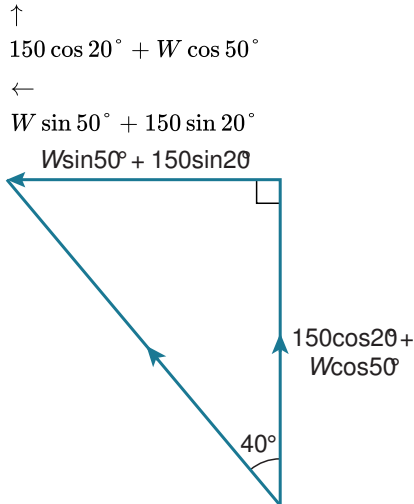

$$\tan 40^\circ = \frac{W \sin 50^\circ + 150 \sin 20^\circ}{150 \cos 20^\circ + W \cos 50^\circ}$$

$$150 \cos 20^\circ \tan 40^\circ + W \cos 50^\circ \tan 40^\circ = W \sin 50^\circ + 150 \sin 20^\circ$$

$$W(\cos 50^\circ \tan 40^\circ - \sin 50^\circ) = 150 \sin 20^\circ - 150 \cos 20^\circ \tan 40^\circ$$

$$W = 295 \text{ N}$$

Another approach to this question would be to draw a triangle of forces and use the sine rule. You should try this method and compare. You may find that you prefer one approach to the other.

13 Let R be the resultant force in the direction of motion.

The maximum deflection occurs when the motor produces a force perpendicular to the direction of motion.

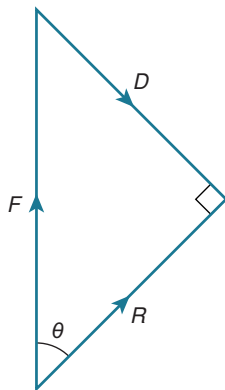

In a right-angled triangle:

$$\sin \theta = \frac{\text{Opp}}{\text{Hyp}} = \frac{D}{F}$$

$$\theta = \sin^{-1}\left(\frac{D}{F}\right)$$

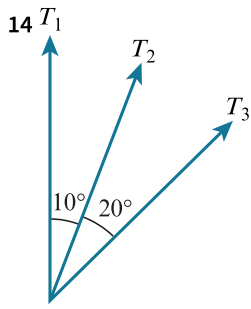

↑

$$T_1 + T_2 \cos 10^\circ + T_3 \cos 30^\circ$$

→

$$T_2 \sin 10^\circ + T_3 \sin 30^\circ$$

$$R = \sqrt{(T_1 + T_2 \cos 10^\circ + T_3 \cos 30^\circ)^2 + (T_2 \sin 10^\circ + T_3 \sin 30^\circ)^2}$$

This needs to be maximized in order to maximise acceleration.

$$T_1 = 300, T_2 = 240, T_3 = 210 \Rightarrow R = 733.04 \text{ N}$$

$$T_1 = 300, T_2 = 210, T_3 = 240 \Rightarrow R = 731.58 \text{ N}$$

$$T_1 = 240, T_2 = 300, T_3 = 210 \Rightarrow R = 734.31 \text{ N}$$

$$T_1 = 240, T_2 = 210, T_3 = 300 \Rightarrow R = 730.81 \text{ N}$$

$$T_1 = 210, T_2 = 240, T_3 = 300 \Rightarrow R = 731.71 \text{ N}$$

$$T_1 = 210, T_2 = 300, T_3 = 240 \Rightarrow R = 733.76 \text{ N}$$

Highest resultant is the third of these arrangements:

$$T_1 (\text{North}) = 240 \text{ (Ben)}$$

$$T_2 (10^\circ) = 300 \text{ (Akhil)}$$

$$T_3 (30^\circ) = 210 \text{ (Khadijah)}$$

$$\text{Net force} = 734 \text{ N}$$

Notice that this means the biggest force is in the middle and the next biggest force is placed next closest to the middle. You might have guessed that placing the strongest force in the middle, with other forces united around it, would produce the largest resultant force.

END-OF-CHAPTER REVIEW EXERCISE 3

1 ↑

$$15 \sin \theta = F \dots\dots [1]$$

→

$$15 \cos \theta = 11 \dots\dots [2]$$

$$\cos \theta = \frac{11}{15}$$

$$\theta = 42.8^\circ$$

$$[1]^2 + [2]^2$$

$$225(\sin^2 \theta + \cos^2 \theta) = F^2 + 121$$

$$F^2 = 225 - 121 = 104$$

$$R = \sqrt{104} = 10.2 \text{ N}$$

2

Re-draw the diagram to show the perpendicular direction clearly.

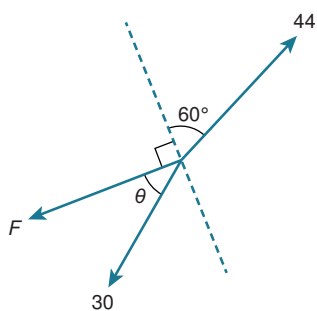

↖ Perpendicular to F

$$44 \cos 60^\circ = 30 \sin \theta$$

$$\sin \theta = \frac{22}{30}$$

$$\theta = 47.2^\circ$$

↗ Parallel to F

$$44 \sin 60^\circ = F + 30 \cos \theta$$

$$F = 44 \sin 60^\circ - 30 \cos \theta$$

$$= 17.7 \text{ N}$$

3 a

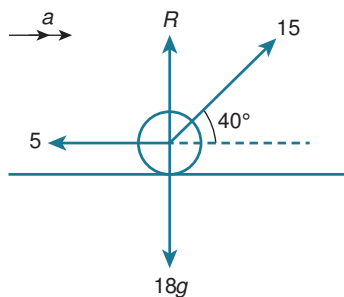

↑

$$R + 15 \sin 40^\circ = 18g$$

$$R = 180 - 15 \sin 40^\circ$$

$$= 170 \text{ N}$$

b →

$$F = ma$$

$$15 \cos 40^\circ - 5 = 18a$$

$$a = \frac{15 \cos 40^\circ - 5}{18} = 0.361 \text{ m s}^{-2}$$

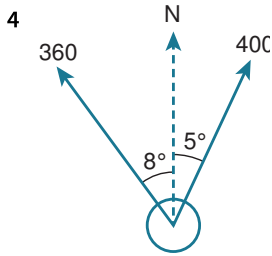

Start by drawing a diagram to show the information. Resolve vertically and horizontally and use these values to find the resultant force.

$$\uparrow$$

$$400 \cos 5^\circ + 360 \cos 8^\circ = 754.974 \dots$$

$$\rightarrow$$

$$400 \sin 5^\circ - 360 \sin 8^\circ = -15.240 \dots$$

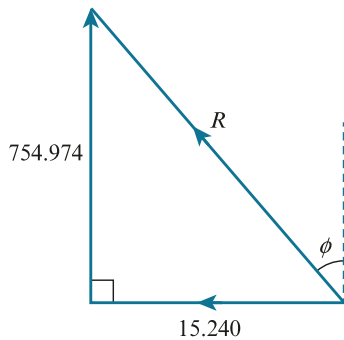

$$R = \sqrt{754.974 \dots^2 + 15.240 \dots^2} = 755 \text{ N}$$

$$F = ma$$

$$755 = 1200 a$$

$$a = 0.629 \text{ m s}^{-2}$$

$$\tan \phi = \frac{15.240 \dots}{754.974 \dots}$$

$$\phi = 1.2^\circ$$

$$\text{Bearing} = 360^\circ - 1.2^\circ = 358.8^\circ$$

5 \rightarrow

$$T \sin \theta = 40 \sin 45^\circ$$

$$T \sin \theta = 40 \left(\frac{\sqrt{2}}{2} \right) = 20\sqrt{2} \dots \dots \dots [1]$$

\uparrow

$$T \cos \theta + 40 \cos 45^\circ = 50$$

$$T \cos \theta = 50 - 40 \left(\frac{\sqrt{2}}{2} \right) = 50 - 20\sqrt{2} \dots \dots [2]$$

[1]

[2]

$$\frac{T \sin \theta}{T \cos \theta} = \frac{20\sqrt{2}}{50 - 20\sqrt{2}}$$

$$\tan \theta = \frac{2\sqrt{2}}{5 - 2\sqrt{2}}$$

$$= \frac{2\sqrt{2}(5 + 2\sqrt{2})}{(5 - 2\sqrt{2})(5 + 2\sqrt{2})}$$

Remember that, to rationalise the denominator for a fraction in the form $\frac{a}{b + \sqrt{c}}$ you multiply the numerator and denominator by $b - \sqrt{c}$.

$$\begin{aligned}
 &= \frac{10\sqrt{2} + 4(\sqrt{2})^2}{25 - (2\sqrt{2})^2} \\
 &= \frac{8 + 10\sqrt{2}}{17} \\
 \theta &= \tan^{-1} \left(\frac{8 + 10\sqrt{2}}{17} \right) = 52.5^\circ
 \end{aligned}$$

$$[1]^2 + [2]^2$$

$$\begin{aligned}
 T^2 \sin^2 \theta + T^2 \cos^2 \theta &= (20\sqrt{2})^2 + (50 - 20\sqrt{2})^2 \\
 T^2 &= (20\sqrt{2})^2 + (50 - 20\sqrt{2})^2 \\
 T &= 35.7 \text{ N}
 \end{aligned}$$

6

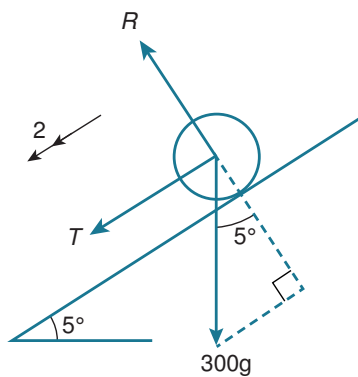

Resultant force = ma

$$\begin{aligned}
 T + 300 g \sin 5^\circ &= 300(2) \\
 T &= 600 - 3000 \sin 5^\circ
 \end{aligned}$$

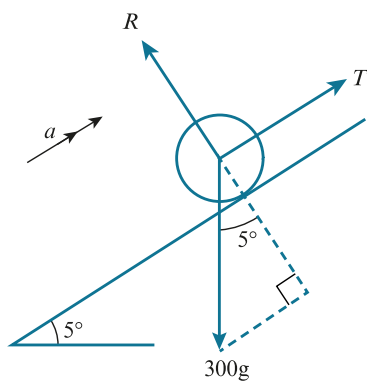

Resultant force = ma

$$\begin{aligned}
 T - 300 g \sin 5^\circ &= 300 a \\
 600 - 3000 \sin 5^\circ - 3000 \sin 5^\circ &= 300 a \\
 600 - 6000 \sin 5^\circ &= 300 a \\
 a &= 2 - 20 \sin 5^\circ = 0.257 \text{ m s}^{-2}
 \end{aligned}$$

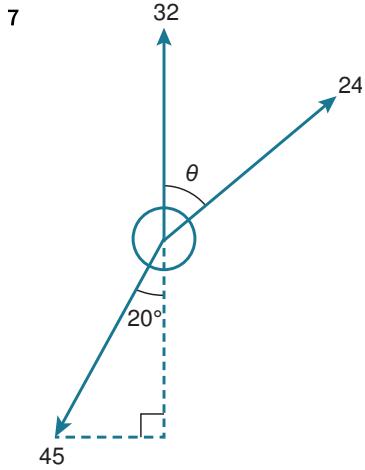

a To produce a force that is parallel to the west-east direction, the north-south resultant force must be zero.

$$\begin{aligned} \uparrow \\ 32 + 24 \cos \theta &= 45 \cos 20^\circ \\ \cos \theta &= 0.42859 \dots \\ \theta &= 64.6^\circ \\ \text{Bearing} &= 064.6^\circ \end{aligned}$$

b \rightarrow

$$\begin{aligned} F &= ma \\ 24 \sin \theta - 45 \sin 20^\circ &= 10a \\ a &= 0.629 \text{ m s}^{-2} \end{aligned}$$

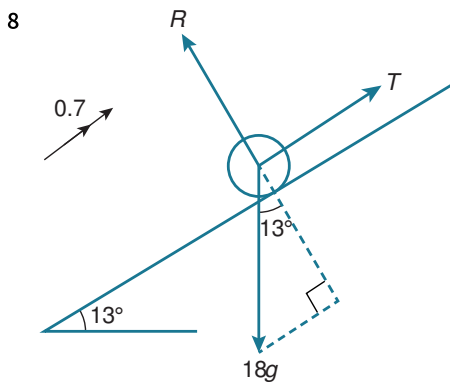

$$\begin{aligned} \nearrow \\ F &= ma \\ T - 18g \sin 13^\circ &= 18(0.7) \\ T &= 180 \sin 13^\circ + 12.6 \end{aligned}$$

You are trying to find the mass of the heaviest block the girls can move up the slope, so you need to assume that it is just at the point where she just cannot move the object. This is limiting equilibrium; the object is just on the point of moving. So we assume equilibrium

Assume equilibrium:

$$\begin{aligned} \nearrow \\ T &= mg \sin 13^\circ \\ 180 \sin 13^\circ + 12.6 &= mg \sin 13^\circ \\ m &= \frac{180 \sin 13^\circ + 12.6}{g \sin 13^\circ} = 23.6 \text{ kg} \end{aligned}$$

9 a

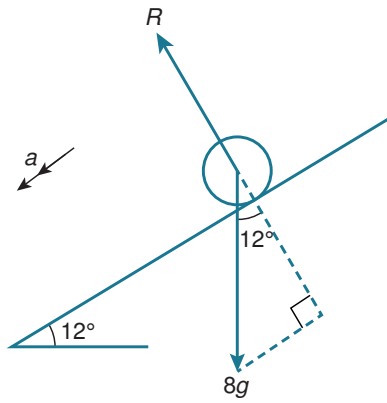

✓

$$F = ma$$

$$8g \sin 12^\circ = 8a$$

$$a = g \sin 12^\circ$$

$$u = 0, s = 6, a = g \sin 12^\circ, t = ?$$

$$s = ut + \frac{1}{2}at^2$$

$$6 = \frac{1}{2}g \sin 12^\circ t^2$$

$$t = \sqrt{\frac{12}{g \sin 12^\circ}} = 2.40 \text{ s}$$

b

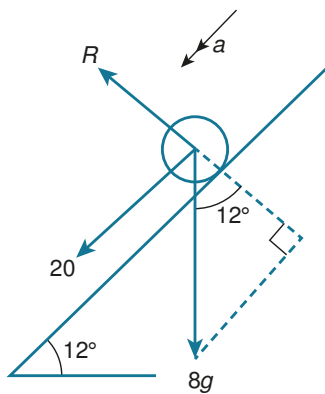

✓

$$F = ma$$

$$8g \sin 12^\circ + 20 = 8a$$

$$a = g \sin 12^\circ + 2.5$$

$$u = 0, s = 6, a = g \sin 12^\circ + 2.5, t = ?$$

$$s = ut + \frac{1}{2}at^2$$

$$6 = \frac{1}{2}(g \sin 12^\circ + 2.5)t^2$$

$$t = \sqrt{\frac{12}{g \sin 12^\circ + 2.5}} = 1.6188 \dots \text{ s}$$

$$\text{Difference} = 0.784 \text{ s}$$

Remember to use the unrounded values when finding the difference.

10

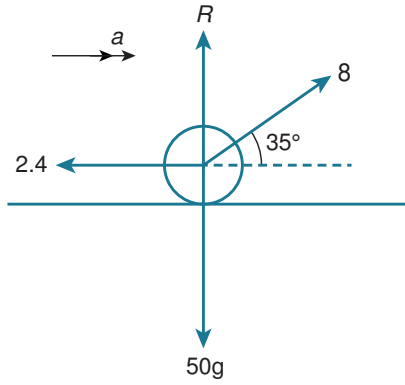

a →

$$F = ma$$

$$8 \cos 35^\circ - 2.4 = 50a$$

$$a = \frac{8 \cos 35^\circ - 2.4}{50}$$

$$u = 0$$

$$v = ?$$

$$s = 2$$

$$v^2 = u^2 + 2as$$

$$v = \sqrt{0 + 4a} = 0.576 \text{ m s}^{-1}$$

b The force is constant and the angle remains unchanged despite the motion starting.

c ←

$$-2.4 = 50a$$

$$a = -\frac{2.4}{50} = -0.048$$

$$u = 0.576, v = 0, a = -0.048, s = ?$$

$$v^2 = u^2 + 2as$$

$$s = \frac{v^2 - u^2}{2a} = 3.46 \text{ m}$$

$$\text{Total} = 3.46 + 2 = 5.46 \text{ m}$$

11 a

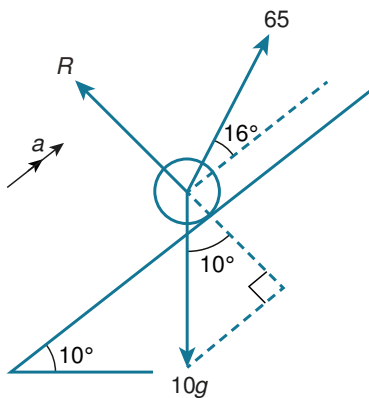

↗

$$F = ma$$

$$65 \cos 16^\circ - 10g \sin 10^\circ = 10a$$

$$a = 6.5 \cos 16^\circ - g \sin 10^\circ$$

$$s = 5$$

$$u = 0$$

$$v = ?$$

$$v^2 = u^2 + 2as$$

$$v = \sqrt{0 + 10a} = 6.72 \text{ m s}^{-1}$$

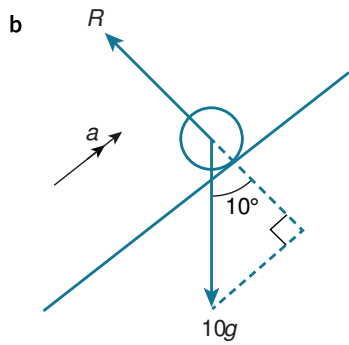

→

$$F = ma$$

$$-10g \sin 10^\circ = 10a$$

$$a = -g \sin 10^\circ$$

$$u = 6.72$$

$$v = 0$$

$$s = ?$$

$$v^2 = u^2 + 2as$$

$$s = \frac{v^2 - u^2}{2a} = \frac{0 - 6.72^2}{-2g \sin 10^\circ} = 13.0 \text{ m}$$

12

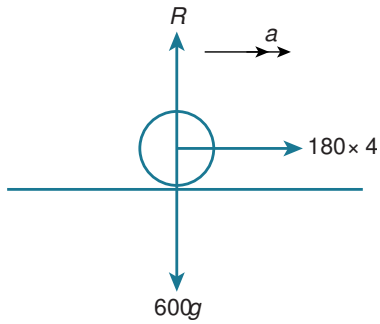

a →

$$4 \times 180 = 600a$$

$$a = 1.2 \text{ m s}^{-2}$$

$$u = 0$$

$$v = ?$$

$$s = 40$$

$$v^2 = u^2 + 2as$$

$$v = \sqrt{0 + 2 \times 1.2 \times 40} = 9.80 \text{ m s}^{-1}$$

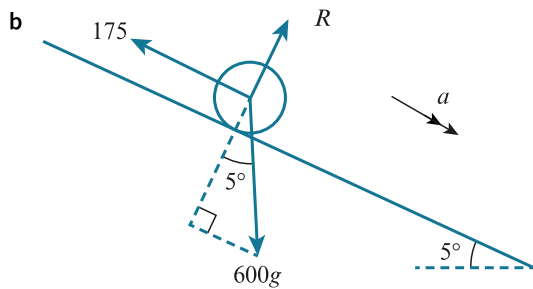

Time for the first part:

$$u = 0$$

$$a = 1.2$$

$$s = 40$$

$$t = ?$$

$$s = ut + \frac{1}{2}at^2$$

$$40 = 0 + 0.6t^2$$

$$t = \sqrt{\frac{40}{0.6}} = 8.16 \text{ s}$$

For the second part:



$$600g \sin 5^\circ - 175 = 600a$$

$$a = g \sin 5^\circ - \frac{175}{600}$$

$$u = 9.80$$

$$s = 1300$$

$$t = ?$$

$$s = ut + \frac{1}{2}at^2$$

$$1300 = 9.8t + 0.2899t^2$$

$$t = -85.9675 < 0 \text{ or } t = 52.1628$$

$$52.1628 + 8.16 \dots = 60.3 \text{ s}$$

13

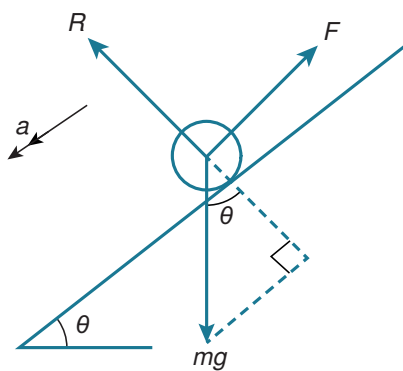

Resultant force = ma

$$mg \sin \theta - F = ma$$

$$a = g \sin \theta - \frac{F}{m} \dots [1]$$

Using suvat equations:

$$v^2 = u^2 + 2as$$

$$v^2 = u^2 + 2ax$$

$$a = \frac{v^2 - u^2}{2x} \dots [2]$$

Substituting [2] into [1]

$$\frac{v^2 - u^2}{2x} = g \sin \theta - \frac{F}{m}$$

$$\frac{F}{m} = g \sin \theta - \frac{v^2 - u^2}{2x}$$

$$= \frac{1}{2x}(2xg \sin \theta - v^2 + u^2)$$

$$F = \frac{m}{2x}(2xg \sin \theta + u^2 - v^2)$$

14

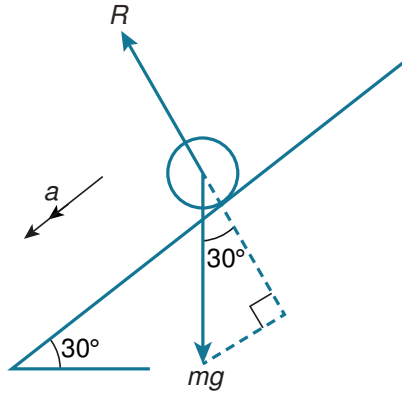

Remember that the acceleration is not constant if forces change during the motion. You need to split the working into sections with different accelerations. You can then treat each section as a constant acceleration problem.

✓

$$F = ma$$

$$mg \sin 30^\circ = ma$$

$$a = \frac{1}{2} g \text{ m s}^{-2}$$

Over the first s metres.

$$a = \frac{1}{2} g$$

$$u = 0$$

$$v = ?$$

$$v^2 = u^2 + 2as$$

$$v = \sqrt{0 + gs} = \sqrt{gs}$$

Booster for 1 metre

✓

$$F = ma$$

$$mg \sin 30^\circ + mg = ma$$

$$a = \frac{1}{2}g + g = \frac{3}{2}g \text{ m s}^{-2}$$

$$u = \sqrt{gs}$$

$$v = ?$$

$$s = 1$$

$$v^2 = u^2 + 2as$$

$$v = \sqrt{gs + 3g}$$

Remaining $x - s - 1$ metres

$$u = \sqrt{gs + 3g}$$

$$v = ?$$

$$a = \frac{1}{2}g$$

Distance = $x - s - 1$

$$v^2 = u^2 + 2as$$

$$v^2 = gs + 3g + g(x - s - 1)$$

$$= gs + 3g + gx - gs - g$$

$$= 2g + gx$$

$$= g(2 + x)$$

This answer is independent of s .

$$15 \tan \alpha = \frac{5}{12}$$

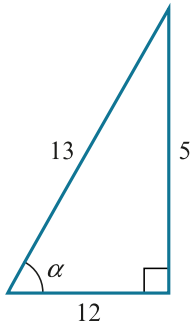

$$\cos \alpha = \frac{12}{13}$$

$$\sin \alpha = \frac{5}{13}$$

↑

$$58 - 26 \sin \alpha$$

$$= 58 - 26 \left(\frac{5}{13} \right)$$

$$= 48$$

→

$$26 \cos \alpha + 31 = 26 \left(\frac{12}{13} \right) + 31$$

$$= 24 + 31$$

$$= 55$$

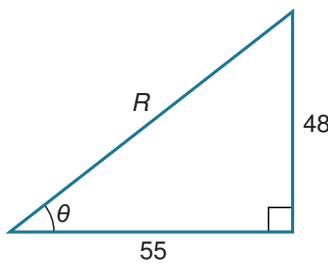

$$\tan \theta = \frac{48}{55}$$

$\theta = 41.1^\circ$ from positive x -direction.

$$R^2 = 48^2 + 55^2$$

$$R = \sqrt{48^2 + 55^2} = 73 \text{ N}$$

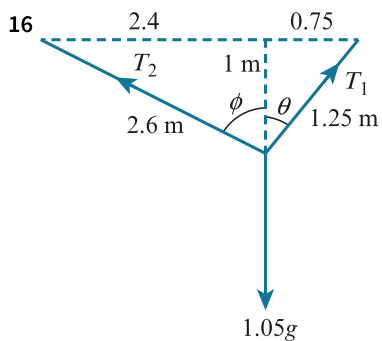

↑

$$T_1 \cos \theta + T_2 \cos \phi = 1.05g$$

$$T_1 \left(\frac{1}{1.25} \right) + T_2 \left(\frac{1}{2.6} \right) = 1.05g$$

$$2.6T_1 + 1.25T_2 = 34.125 \dots [1]$$

→

$$T_1 \sin \theta = T_2 \sin \phi$$

$$\frac{0.75}{1.25} T_1 = \frac{2.4}{2.6} T_2$$

$$T_1 = \frac{2.4 \times 1.25}{0.75 \times 2.6} T_2 = \frac{3}{1.95} T_2 \dots [2]$$

Substitute [2] into [1]

$$\frac{2.6 \times 3}{1.95} T_2 + 1.25 T_2 = 34.125$$

$$T_2 = 6.5 \text{ N}$$

$$T_1 = \frac{3}{1.95} \times 6.5 = 10 \text{ N}$$

17

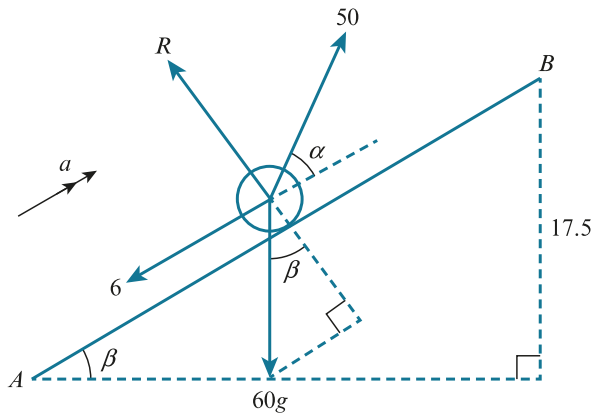

Start by finding the acceleration required to change speed from 8.5 m s^{-1} to 3.5 m s^{-1} in 250 m. Once you know the acceleration, find the angle of the slope using the fact that B is 17.5 m above A and 250 m further along the slope. The appropriate right-angled triangle is shown in the diagram. You can now complete the question by resolving forces.

Using the equations of constant acceleration:

$$u = 8.5$$

$$v = 3.5$$

$$s = 250$$

$$a = ?$$

$$v^2 = u^2 + 2as$$

$$a = \frac{v^2 - u^2}{2s}$$

$$= \frac{3.5^2 - 8.5^2}{2 \times 250}$$

$$= -0.12$$

↗

$$F = ma$$

$$50 \cos \alpha - 6 - 60g \sin \beta = 60(-0.12)$$

$$50 \cos \alpha = 6 + 60g \sin \beta - 60 \times 0.12$$

$$= 600 \times 0.07 - 1.2$$

$$\cos \alpha = \frac{600 \times 0.07 - 1.2}{50}$$

$$\alpha = 35.3^\circ$$

CROSS-TOPIC REVIEW EXERCISE 1

1 $u = 20$

$v = 24$

$a = ?$

$t = 10$

$v = u + at$

$$a = \frac{v - u}{t} = \frac{24 - 20}{10} = 0.4 \text{ m s}^{-2}$$

→

$$F = ma$$

$$D - 100 = 1500(0.4)$$

$$D = 600 + 100 = 700 \text{ N}$$

2

When the problem is broken into clear stages, make sure that you state what is happening in each stage before you show your working. This makes it a lot easier to keep things in the right order.

a $a = 0.8$

$u = 0$

$t = 5$

$$v = u + at = 0 + 4 = 4 \text{ m s}^{-1} \text{ at } t = 5\text{s}$$

Distance covered in the first 5 seconds

$$s = ut + \frac{1}{2}at^2$$

$$= 0.4(5^2) = 10 \text{ m}$$

Distance covered in the next 25 seconds

$$s = vt = 4(25) = 100 \text{ m}$$

$$\text{Remaining distance} = 145 - 100 - 10 = 35 \text{ m}$$

$$s = 35$$

$$u = 4$$

$$t = 10$$

$$v = ?$$

$$s = \left(\frac{u + v}{2} \right) t$$

$$35 = \left(\frac{4 + v}{2} \right) 10$$

$$v = 3 \text{ m s}^{-1}$$

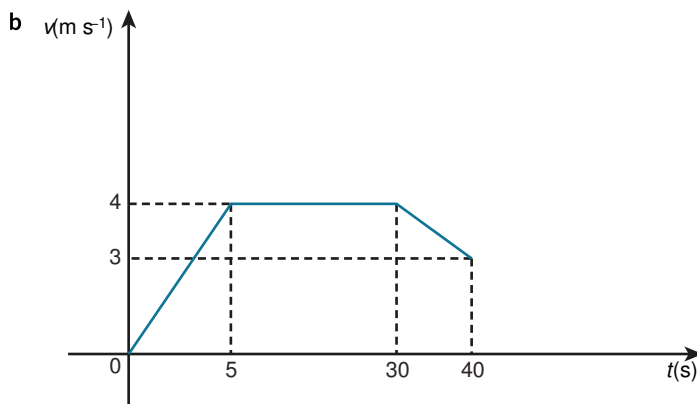

When asked to draw a velocity-time graph make sure that you include as much detail as you can. It is particularly important to mark any velocities or times at points where the situation changes to a new stage.

3

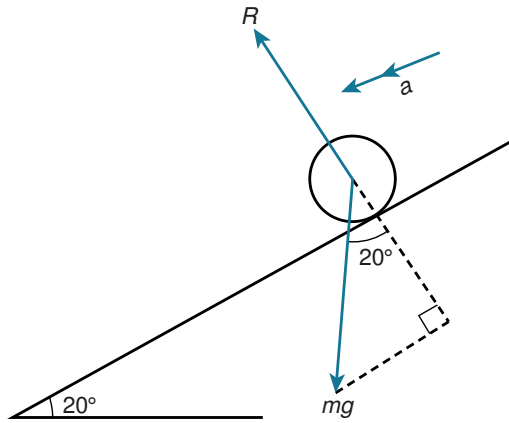

a ✓

$$F = ma$$

$$mg \sin 20^\circ = ma$$

$$a = g \sin 20^\circ$$

$$u = 0$$

$$a = g \sin 20^\circ$$

$$t = 0.7$$

$$v = u + at = 0.7g \sin 20^\circ = 2.39 \text{ m s}^{-1}$$

b $s = 1.2$

$$a = g \sin 20^\circ$$

$$u = 0$$

$$v^2 = u^2 + 2as$$

$$v = \sqrt{0 + 2(g \sin 20^\circ)(1.2)} = 2.87 \text{ m s}^{-1}$$

4 $s = 2$

$$t = 5$$

$$u = 0$$

$$s = ut + \frac{1}{2}at^2$$

$$2 = 0 + \frac{25}{2}a$$

$$a = \frac{4}{25} \text{ m s}^{-2}$$

$$\text{mass} = \frac{400}{g} = 40 \text{ kg}$$

$$F = ma$$

$$R - 400 = 40 \left(\frac{4}{25} \right)$$

$$R = 400 + \frac{160}{25} = 406.4 \text{ N}$$

5 a

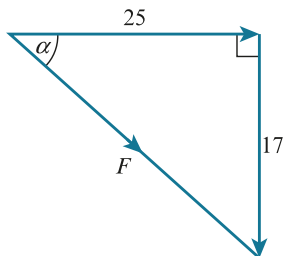

$$\tan \alpha = \frac{17}{25}$$

$$\alpha = 34.2^\circ$$

$$F^2 = 25^2 + 17^2 = 625 + 289 = 914$$

$$F = \sqrt{914} = 30.2 \text{ N}$$

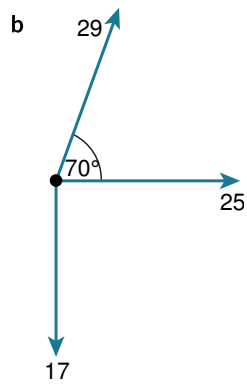

↑

$$29 \sin 70^\circ - 17 = 10.251\dots$$

→

$$25 + 29 \cos 70^\circ = 34.918\dots$$

$$R^2 = 34.919^2 + 10.251^2$$

$$R = 36.4 \text{ N}$$

$$\tan \theta = \frac{10.251}{34.919}$$

$$\theta = 16.4^\circ$$

6 a Area under the graph = $\frac{1}{4} \times 4 \times 40 + \left(\frac{40+8}{2}\right) \times 5 + 41 \times 8$
 $= 80 + 120 + 328$
 $= 528 \text{ m}$

b Acceleration is $\frac{40-8}{5} = \frac{32}{5} = 6.4 \text{ m s}^{-2}$ upwards (to slow the fall)

Remember that on a velocity–time graph the gradient of the line gives the acceleration.

↑

Resultant force = ma

$$F - 70g = 70 \times 6.4$$

$$F = 1148 \text{ N}$$

7

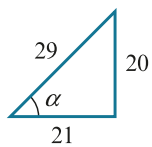

$$\tan \alpha = \frac{20}{21}$$

$$\cos \alpha = \frac{21}{29}$$

$$\sin \alpha = \frac{20}{29}$$

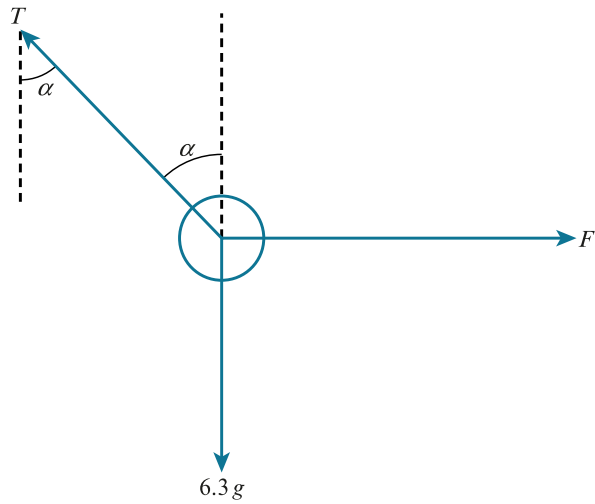

$$\uparrow$$

$$T \cos \alpha = 6.3g$$

$$\frac{21}{29}T = 6.3g$$

$$T = 87 \text{ N}$$

$$\rightarrow$$

$$F = T \sin \alpha = 87 \times \frac{20}{29} = 60 \text{ N}$$

8 a

Because the two forces are equal the angle between each of them and the resultant force must be equal.

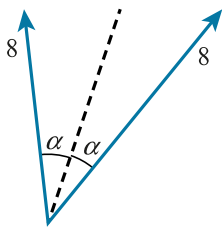

$$2 \times 8 \cos \alpha = 13$$

$$\cos \alpha = \frac{13}{16}$$

$$\alpha = 35.659\dots$$

$$2\alpha = 71.3^\circ$$

b

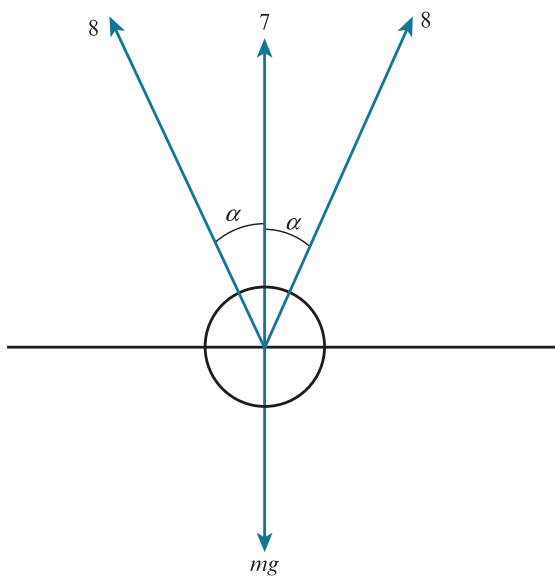

$$\begin{aligned} \uparrow \\ 13 + 7 &= mg \\ m &= 2 \text{ kg} \\ 90 - \alpha &= 54.3^\circ \end{aligned}$$

9 a \rightarrow

$$12 \cos 40^\circ + 10 \cos 35^\circ - 7 \cos 50^\circ = 12.9 \text{ N}$$

\uparrow

$$12 \sin 40^\circ + 7 \sin 50^\circ - 10 \sin 35^\circ = 7.34 \text{ N}$$

b $R^2 = 7.34^2 + 12.9^2$
 $R = 14.8 \text{ N}$
 $\tan \theta = \frac{7.34}{12.9}$
 $\theta = 29.6^\circ$

10 a You do not really need a diagram for this question, but it is often useful to draw one anyway. It can be a really helpful way of summarising the information given in the question.

Let the speed at $A = u \text{ ms}^{-2}$

At B :

$$s = ut + \frac{1}{2}at^2$$

$$32 = 4u + 8a \quad \dots\dots\dots [1]$$

$$v = u + at = u + 4a$$

At C :

$$s = ut + \frac{1}{2}at^2$$

$$19 = (u + 4a) \times 2 + \frac{1}{2}a \times 2^2$$

$$19 = 2u + 8a + 2a$$

$$10a + 2u = 19 \quad \dots\dots\dots [2]$$

$\frac{[1]}{2}$ gives

$$4a + 2u = 16 \quad \dots\dots\dots [3]$$

$[2] - [3]$ gives

$$6a = 3$$

$$a = 0.5 \text{ ms}^{-2}$$

In this solution we consider the sections AB and BC . Alternatively you could consider AB and AC ; in this case at C : $u = u$, $s = 51$ and $t = 6$.

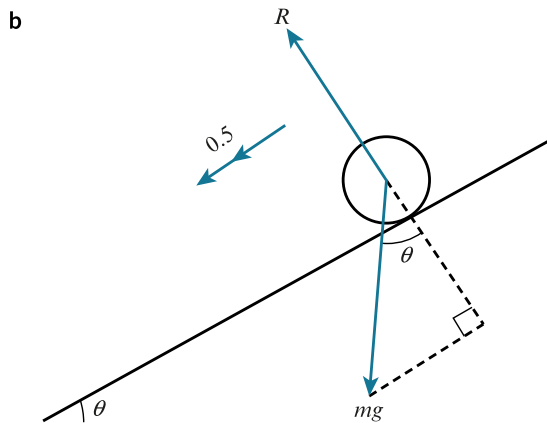

✓

$$F = ma$$
$$mg \sin \theta = m(0.5)$$
$$\sin \theta = 0.05$$
$$\theta = 2.9^\circ$$

11 ↑

$$6 \sin \alpha = F + 5 \sin(90^\circ - \alpha)$$

$$6 \sin \alpha = F + 5 \cos \alpha \dots\dots\dots [1]$$

→

$$F = 5 \cos(90^\circ - \alpha) + 6 \cos \alpha$$

$$F = 5 \sin \alpha + 6 \cos \alpha \dots\dots\dots [2]$$

Substituting [2] into [1]

$$6 \sin \alpha = 5 \sin \alpha + 6 \cos \alpha + 5 \cos \alpha$$

$$\sin \alpha = 11 \cos \alpha$$

$$\tan \alpha = 11$$

$$\alpha = 84.8^\circ$$

$$F = 5 \sin \alpha + 6 \cos \alpha = 5.52 \text{ N}$$

12 i First work out how long the cyclist takes to complete the first phase of motion and the speed at the end of this first stage.

$$s = ut + \frac{1}{2}at^2$$

$$36 = 0 + \frac{1}{4}t^2$$

$$t = 12\text{s}$$

$$v = u + at$$

$$v = 0 + \frac{1}{2}(12) = 6\text{m s}^{-1}$$

Distance travelled in the second phase:

$$s = vt$$

$$s = 6(25) = 150 \text{ m}$$

$$\text{Remaining distance} = 210 - (150 + 36) = 24 \text{ m}$$

Time to complete the second phase:

$$s = \left(\frac{u+v}{2}\right)t$$

$$24 = \left(\frac{6+0}{2}\right)t$$

$$t = 8\text{s}$$

So the time taken to travel from *A* to *B* = 12 + 25 + 8 = 45 seconds

ii

When the car overtakes the cyclist, both have travelled the same distance. This means you need to find an expression for both distances in terms of *t* and equate them to find *t*. Be careful how you define *t* and make sure that your final answer is the time from when the cyclist starts.

At the moment the car starts to move, the distance travelled by the cyclist is required:

$$36 + (24 - 12) \times 6 = 108 \text{ m}$$

After a further *t* seconds:

Car distance from *A*:

$$s = ut + \frac{1}{2}at^2$$

$$s = 2t^2$$

Cyclist distance from *A*:

$$s = 108 + 6t$$

Overtakes when

$$2t^2 = 108 + 6t$$

$$t^2 - 3t - 54 = 0$$

$$(t - 9)(t + 6) = 0$$

$$t = 9 \text{ or } t = -6$$

$$t > 0$$

$$t = 9$$

$$\text{Total time } 9 + 24 = 33\text{s}$$

13 i

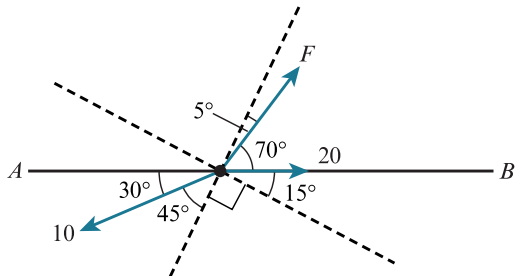

Perpendicular to R the forces are balanced, so:

$$F \cos 5^\circ + 20 \sin 15^\circ = 10 \sin 45^\circ$$

$$F = \frac{10 \sin 45^\circ - 20 \sin 15^\circ}{\cos 5^\circ} = 1.90$$

Resolve parallel to R to find R :

$$R = F \cos 85^\circ + 20 \cos 15^\circ - 10 \cos 45^\circ$$

$$= 12.4$$

ii $v^2 = u^2 + 2as$

$$a = \frac{v^2 - u^2}{2s}$$

$$= \frac{11.7^2 - 0}{6}$$

$$= \frac{4563}{200}$$

→

$$R \cos 15^\circ = ma$$

$$(12.4 \dots) \cos 15^\circ = m \left(\frac{4563}{200} \right)$$

$$m = 0.526 \text{ kg}$$

14

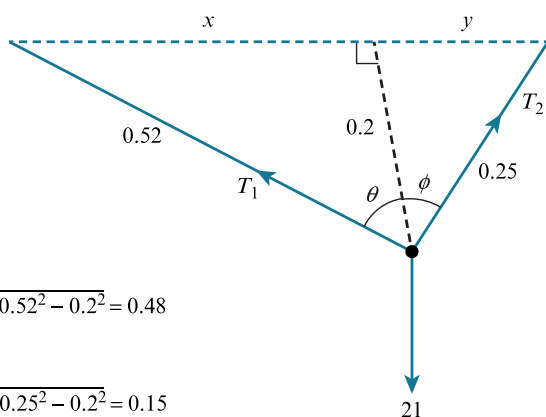

$$x = \sqrt{0.52^2 - 0.2^2} = 0.48$$

$$y = \sqrt{0.25^2 - 0.2^2} = 0.15$$

→

$$T_2 \sin \phi = T_1 \sin \theta$$

$$\frac{0.15}{0.25} T_2 = \frac{0.48}{0.52} T_1$$

$$T_1 = \frac{13}{20} T_2$$

↑

$$T_1 \cos \theta + T_2 \cos \phi = 21$$

$$\frac{0.2}{0.52}T_1 + \frac{0.2}{0.25}T_2 = 21$$

$$\frac{5}{13}T_1 + \frac{4}{5}T_2 = 21$$

$$\frac{5}{13} \left(\frac{13T_2}{20} \right) + \frac{4}{5}T_2 = 21$$

$$\frac{21}{20}T_2 = 21$$

$$T_2 = 20 \text{ N}$$

$$T_1 = \left(\frac{13}{20} \right) 20 = 13 \text{ N}$$

Chapter 4

Friction

EXERCISE 4A

- 1 a If an object remains at rest then the system of forces acting on the object must be in equilibrium.

←

$F = 40 \text{ N}$ to the left

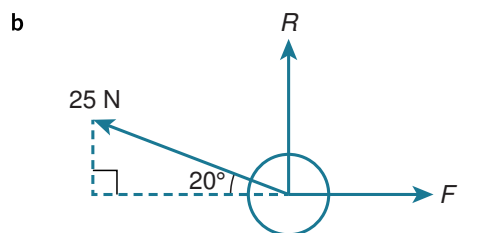

→

$F = 25 \cos 20^\circ = 23.5 \text{ N}$ to the right

- c This will be zero. Friction will only be non-zero if there is a non-zero force trying to move the object against a surface.

- 2 a

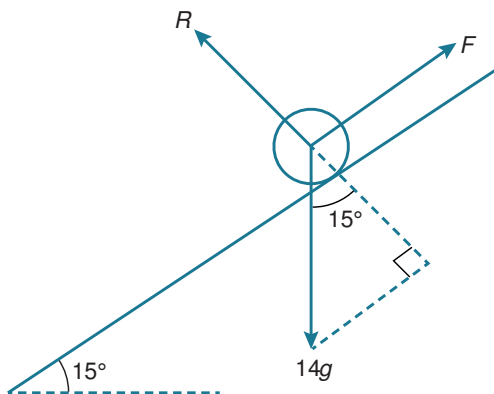

↗

$F = 14g \sin 15^\circ$
 $= 36.2 \text{ N}$ up the slope.

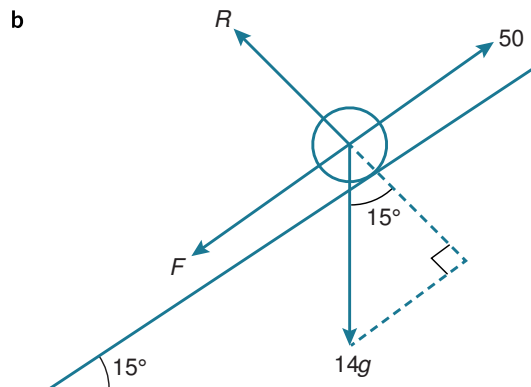

Assume that F acts down the slope.

If you are not told the direction of friction then just choose one. If you happen to choose the wrong direction then the friction will come out as negative. This isn't actually wrong; it just tells you that the friction is in the opposite direction to the one you chose.



$$50 = F + 14g \sin 15^\circ$$

$$F = 13.8 \text{ N down the slope}$$

c

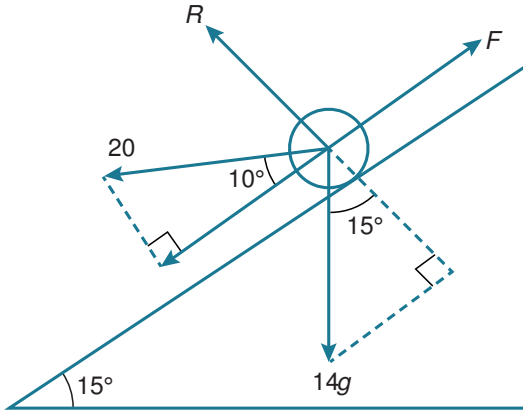

$$F = 14g \sin 15^\circ + 20 \cos 10^\circ$$

$$= 55.9 \text{ N up the slope}$$

d

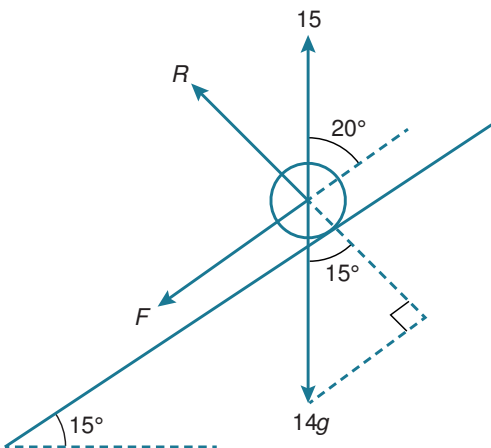

$$15 \cos 20^\circ = F + 14g \sin 15^\circ$$

$$F = 15 \cos 20^\circ - 14g \sin 15^\circ$$

$$= -22.1 \text{ N down the slope}$$

So

22.1 N up the slope

By 'up the slope' we mean along the line of greatest slope, i.e. the steepest possible path and the shortest route.

3 a →

$$F = 40$$

↑

$$R = 20g$$

$$C^2 = 200^2 + 40^2$$

$$C = 204 \text{ N}$$

b →

$$F = 50 \cos 15^\circ$$

↑

$$R + 50 \sin 15^\circ = 20g$$

$$R = 20g - 50 \sin 15^\circ$$

$$C^2 = (20g - 50 \sin 15^\circ)^2 + (50 \cos 15^\circ)^2$$

$$C = 193 \text{ N}$$

c →

$$F = 50 \cos 15^\circ$$

↑

$$R = 50 \sin 15^\circ + 20g$$

$$C = \sqrt{(50 \sin 15^\circ + 20g)^2 + (50 \cos 15^\circ)^2}$$

$$= 218 \text{ N}$$

4 a

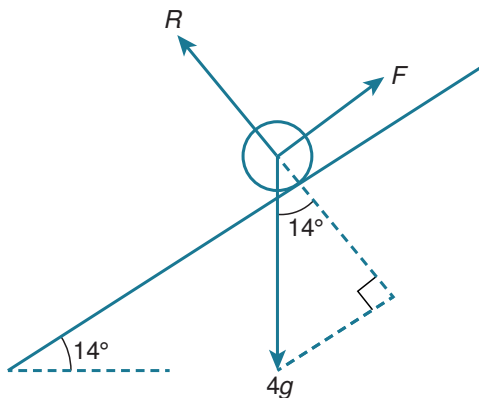

As the only force opposing the weight is the resultant of the friction and normal contact force

$$\text{Contact force} = 4g = 40 \text{ N}$$

This situation only occurs if the system only includes a weight, friction and a normal contact force. When it does occur, the contact force is always vertically upwards, with a magnitude equal to the weight.

b ↖

$$R = 4g \cos 14^\circ$$

↗

$$F = 5 + 4g \sin 14^\circ$$

$$C = \sqrt{(4g \cos 14^\circ)^2 + (5 + 4g \sin 14^\circ)^2}$$

$$= 41.5 \text{ N}$$

c

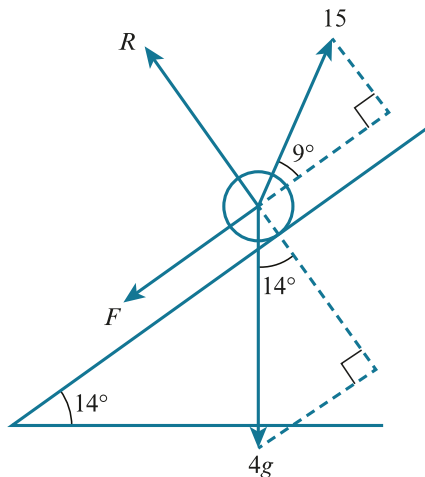

$$\begin{aligned} \nwarrow \\ R + 15 \sin 9^\circ &= 4g \cos 14^\circ \\ R &= 4g \cos 14^\circ - 15 \sin 9^\circ \\ \nearrow \\ 15 \cos 9^\circ &= F + 4g \sin 14^\circ \\ F &= 15 \cos 9^\circ - 4g \sin 14^\circ \\ C &= \sqrt{F^2 + R^2} = 36.8 \text{ N} \end{aligned}$$

5 ↑

$$R = 0.5g$$

Limiting equilibrium:

$$F = \mu R = 0.3R = 0.15g = 1.5 \text{ N}$$

Maximum possible force is equal and opposite: 1.5 N

6 a

P will be at its minimum when the friction has maximum value up the slope. In this situation the friction is helping the force to support the object.

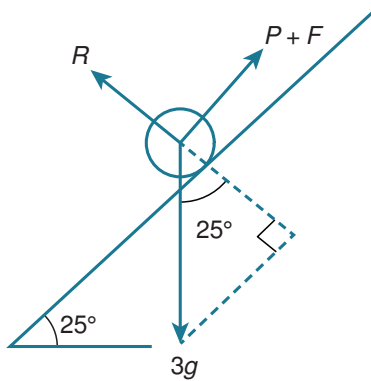

$$\begin{aligned} \nearrow \\ P + F &= 3g \sin 25^\circ \\ \nwarrow \\ R &= 3g \cos 25^\circ \\ F &= \mu R \\ &= 0.4(3g \cos 25^\circ) \\ P + 0.4(3g \cos 25^\circ) &= 3g \sin 25^\circ \\ P &= 3g \sin 25^\circ - 1.2g \cos 25^\circ = 1.8 \text{ N} \end{aligned}$$

b

P will take a maximum value when it needs to overcome maximum resistance from friction in the opposite direction.

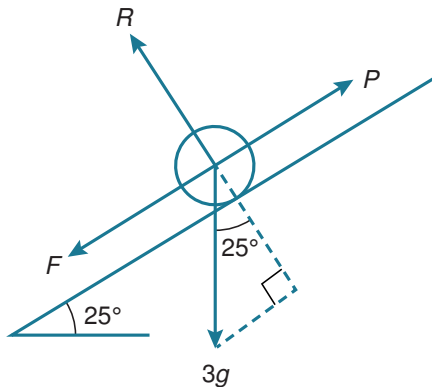

$$\begin{aligned} \nwarrow \\ R &= 3g \cos 25^\circ \\ \nearrow \\ P &= F + 3g \sin 25^\circ \\ F &= \mu R \\ P &= 0.4(3g \cos 25^\circ) + 3g \sin 25^\circ = 23.6 \text{ N} \end{aligned}$$

7 Remember that if the object is on the point of slipping, then the friction will be at its maximum possible value, μR .

$$\begin{aligned} F &= 0.35R \\ \rightarrow \\ F &= 25 \\ 25 &= 0.35R \\ R &= \frac{500}{7} \\ \uparrow \\ R &= 6g + P \\ 6g + P &= \frac{500}{7} \\ P &= \frac{500}{7} - 6g = 11.4 \text{ N} \end{aligned}$$

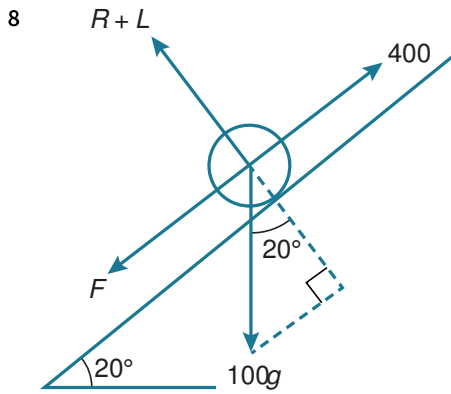

Point of slipping: $F = 0.25 R$

$$\begin{aligned} \nearrow \\ 400 &= F + 100g \sin 20^\circ \\ F &= 400 - 100g \sin 20^\circ \\ R &= \frac{400 - 100g \sin 20^\circ}{0.25} \\ \nwarrow \\ R + L &= 100g \cos 20^\circ \\ L &= 100g \cos 20^\circ - (1600 - 400g \sin 20^\circ) \\ &= 708 \text{ N} \end{aligned}$$

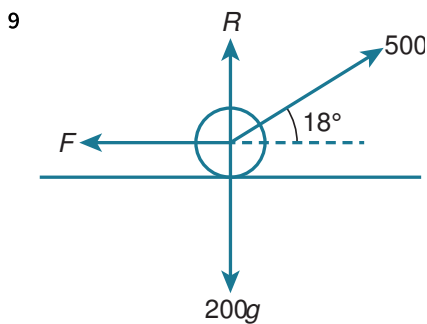

Point of slipping:

$$F = \mu R$$

↑

$$R + 500 \sin 18^\circ = 200g$$

$$R = 200g - 500 \sin 18^\circ$$

→

$$500 \cos 18^\circ = F$$

$$500 \cos 18^\circ = \mu(200g - 500 \sin 18^\circ)$$

$$\mu = \frac{500 \cos 18^\circ}{200g - 500 \sin 18^\circ} = 0.258$$

10 a

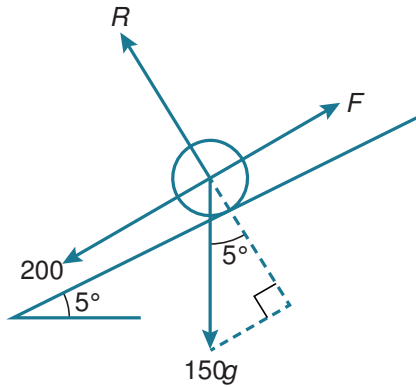

Point of slipping:

$$F = \mu R$$

↖

$$F = \mu(150g \cos 5^\circ)$$

↗

$$F = 200 + 150g \sin 5^\circ$$

$$\mu = \frac{200 + 150g \sin 5^\circ}{150g \cos 5^\circ} = 0.221$$

b The roller is modelled as a particle, so that it does not roll down the slope.

11

If you are searching for the minimum coefficient of friction, consider the limiting case when the object is just about to slip. At this point the friction is just enough to hold the object in place. Any smaller coefficient of friction will give smaller maximum friction and the object will slip.

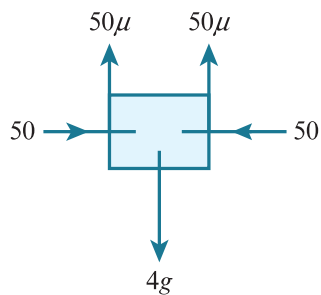

↑

$$100\mu = 4g$$

$$\mu = 0.4$$

12 If the box does not slip down then the friction and the girl's efforts just hold the box in place. Friction must be up the slope.

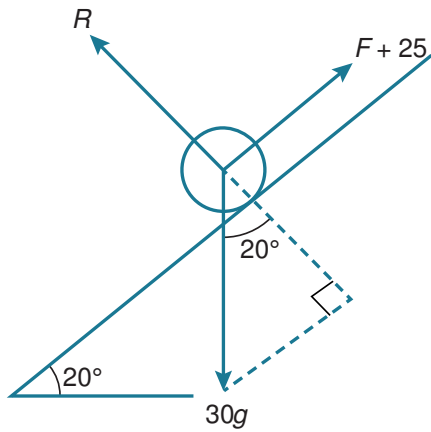

We require:



$$F + 25 \geq 30g \sin 20^\circ$$

$$F \geq 30g \sin 20^\circ - 25$$



$$R = 30g \cos 20^\circ$$

About to slip

$$F = \mu R$$

$$\mu(30g \cos 20^\circ) \geq 30g \sin 20^\circ - 25$$

$$\mu \geq \frac{30g \sin 20^\circ - 25}{30g \cos 20^\circ}$$

$$\mu \geq 0.275$$

13 $F = \mu R$

$$F = 60 \cos 50^\circ$$

$$R = 60 \sin 50^\circ - 2.5g$$

$$60 \cos 50^\circ = \mu(60 \sin 50^\circ - 2.5g)$$

$$\mu = \frac{60 \cos 50^\circ}{60 \sin 50^\circ - 2.5g} = 1.84$$

It is possible for the coefficient of friction to be greater than 1. It is a common error to assume that the coefficient is always less than 1.

14 About to slip up the slope:

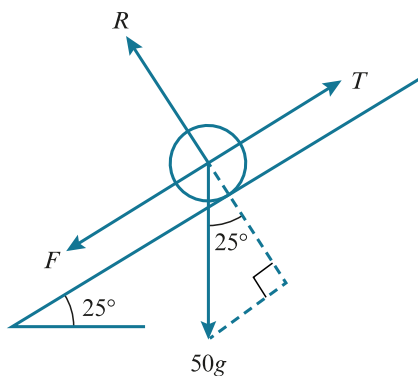

$$T = F + 50g \sin 26^\circ$$



$$R = 50g \cos 26^\circ$$

$$F = 0.4(50g \cos 26^\circ)$$

$$T = 0.4(50g \cos 26^\circ) + 50g \sin 26^\circ$$

$$= 399 \text{ N}$$

Reverse the sign of F to change its direction up the slope

$$T = -0.4(50g \cos 26^\circ) + 50g \sin 26^\circ = 39.4 \text{ N}$$

So $39.4 \text{ N} \leq T \leq 399 \text{ N}$

15 a Contact force = resultant of normal contact and friction forces

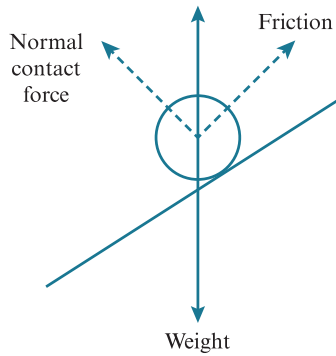

You cannot assume limiting equilibrium because you only know the man has been unsuccessful. You are not told that the car is on the point of slipping.

↖

$$R = 1350g \cos 7^\circ$$

↗

$$F = 500 + 1350g \sin 7^\circ$$

$$\text{Angle that } C \text{ makes with slope} = 90^\circ - \tan^{-1} \left(\frac{F}{R} \right) = 80.9^\circ$$

b Total contact force must exactly oppose the weight, so it acts vertically upwards. This means that the contact force acts at $90^\circ - 7^\circ = 83^\circ$ to the upwards slope.

16 a

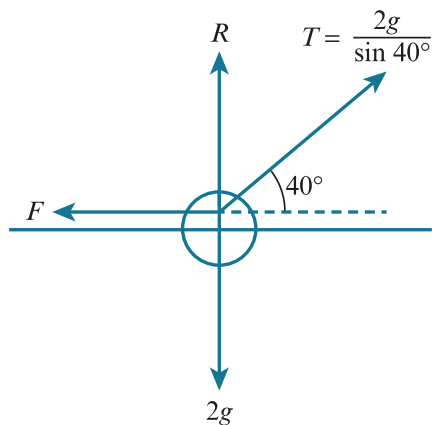

Vertical component of forces:

$$\begin{aligned} T \sin 40^\circ - 2g \\ = 2g - 2g = 0 \end{aligned}$$

At this point the normal contact force is zero, so the maximum possible friction is zero. This means that the only horizontal force is the horizontal component of the tension and so the object must accelerate to the right.

b $T = 100 > \frac{2g}{\sin 40^\circ}$

So the reaction force must now be downwards.

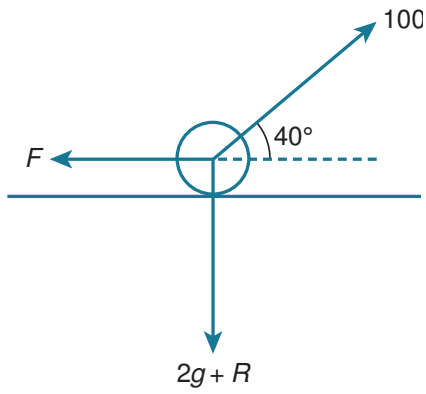

→

$$100 \cos 40^\circ \leq \mu R$$

↑

$$100 \sin 40^\circ = 2g + R$$

$$R = 100 \sin 40^\circ - 2g$$

$$\mu \geq \frac{100 \cos 40^\circ}{100 \sin 40^\circ - 2g}$$

$$\mu \geq 1.73$$

If the tension now increases to 200 N:

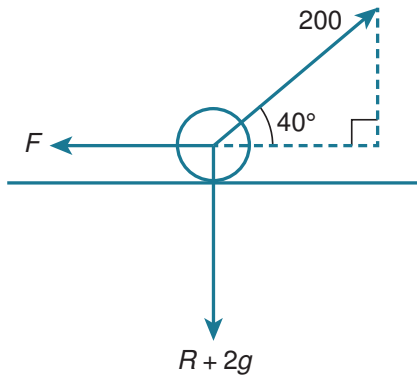

→

$$200 \cos 40^\circ \leq F$$

↑

$$200 \sin 40^\circ = 2g + R$$

$$R = 200 \sin 40^\circ - 2g$$

$$200 \cos 40^\circ \leq \mu(200 \sin 40^\circ - 2g)$$

$$\mu \geq \frac{200 \cos 40^\circ}{200 \sin 40^\circ - 2g}$$

$$\mu \geq 1.41$$

As the tension increases, the normal contact force increases, thereby increasing friction, so a smaller coefficient of friction may be enough to prevent motion.

- 17 There are two possible cases: that the normal contact force points upwards, or it points downwards. In both cases the horizontal component of tension needs to be less than the maximum friction to maintain equilibrium.

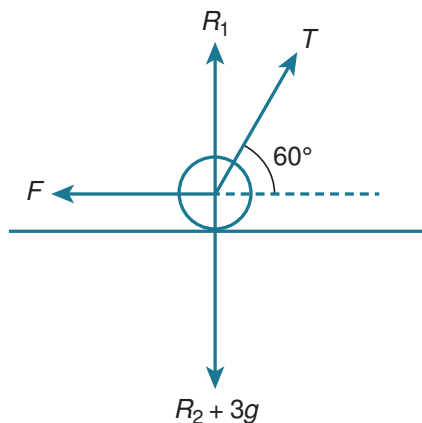

First assume that the normal contact force points upwards, so $R_2 = 0$.

↑

$$T \sin 60^\circ + R_1 = 3g$$

To maintain equilibrium, $T \cos 60^\circ \leq F_{\max}$

→

$$T \cos 60^\circ \leq 0.7R_1$$

$$T \cos 60^\circ \leq 0.7(3g - T \sin 60^\circ)$$

$$T \cos 60^\circ \leq 21 - 0.7T \sin 60^\circ$$

$$T(\cos 60^\circ + 0.7 \sin 60^\circ) \leq 21$$

$$T \leq \frac{21}{\cos 60^\circ + 0.7 \sin 60^\circ} = 18.98\dots$$

$$T \leq 19.0 \text{ N}$$

Next assume that the normal contact force points downwards, so $R_1 = 0$.

↑

$$T \sin 60^\circ = 3g + R_2$$

To maintain equilibrium, $T \cos 60^\circ \leq F_{\max}$

→

$$T \cos 60^\circ \leq 0.7R_2$$

$$T \cos 60^\circ \leq 0.7(T \sin 60^\circ - 3g)$$

$$21 \leq 0.7T \sin 60^\circ - T \cos 60^\circ$$

$$21 \leq T(0.7 \sin 60^\circ - \cos 60^\circ)$$

$$T \geq 198 \text{ N}$$

Note that $198 \sin 60^\circ = 171.5 > 3g$, so the upward component of the tension easily overcomes the weight, forcing the normal contact force to point downwards.

So

$$0 \text{ N} \leq T \leq 19.0 \text{ N} \text{ or } T \geq 198 \text{ N}$$

EXERCISE 4B

1 a \uparrow

$$R = 14g = 140 \text{ N}$$

b $F = 0.1R$

$$= 0.1(140)$$

$$= 14 \text{ N}$$

c \rightarrow

Resultant force = ma

$$21 - F = 14a$$

$$21 - 14 = 14a$$

$$a = 0.5 \text{ m s}^{-2}$$

2

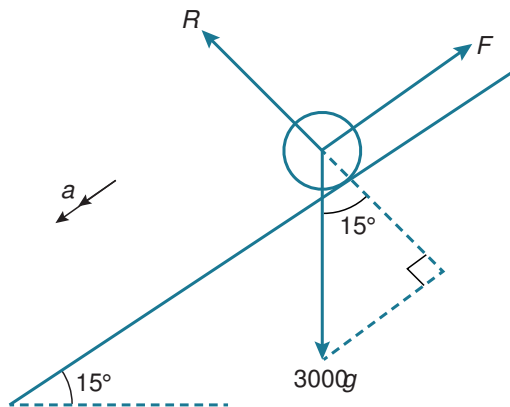

a \nwarrow

$$R = 3000g \cos 15^\circ$$

$$= 29000 \text{ N}$$

b

Always keep reminding yourself: $F = \mu R$ only if the object is moving or about to move.

$$F = 0.25R$$

$$= 7240 \text{ N}$$

c \checkmark

Resultant force = ma

$$3000g \sin 15^\circ - 0.25R = 3000a$$

$$a = \frac{3000g \sin 15^\circ - 0.25R}{3000}$$

$$= 0.173 \text{ m s}^{-2}$$

3

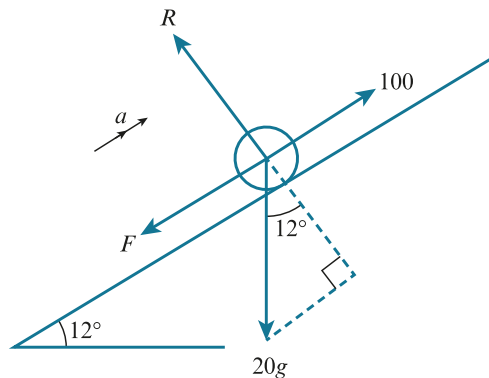

\nwarrow

$$R = 20g \cos 12^\circ$$

$$F = 0.28(20g \cos 12^\circ)$$

↗

Resultant force = ma

$$100 - F - 20g \sin 12^\circ = 20a$$

$$a = \frac{100 - 0.28(20g \cos 12^\circ) - 20g \sin 12^\circ}{20}$$

$$= 0.182 \text{ m s}^{-2}$$

Questions involving slopes often require the use of lots of sine and cosine calculations. These almost always give lots of decimals to handle, so try to keep them in exact form for as long as possible. This way you are most likely to get an accurate final answer.

4

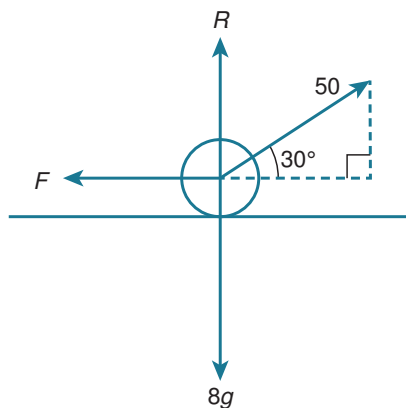

a ↑

$$R + 50 \sin 30^\circ = 8g$$

$$R = 80 - 25 = 55 \text{ N}$$

$$F = 0.6R = 0.6(55) = 33 \text{ N}$$

→

Resultant force = ma

$$50 \cos 30^\circ - 33 = 8a$$

$$a = \frac{50 \cos 30^\circ - 33}{8} = 1.29 \text{ m s}^{-2}$$

b R increases to $55 + 20g = 255 \text{ N}$

$$F = 0.6(255) = 153 \text{ N}$$

Horizontal component of force produced by gardener

$$= 50 \cos 30^\circ < 153$$

So it doesn't move.

5 →

Resultant force = ma

$$20000 - F = 3000(2.2)$$

$$F = 20000 - 6600$$

$$= 13400$$

↑

$$R = 3000g = 30000$$

$$\mu = \frac{F}{R} = \frac{13400}{30000} = 0.447$$

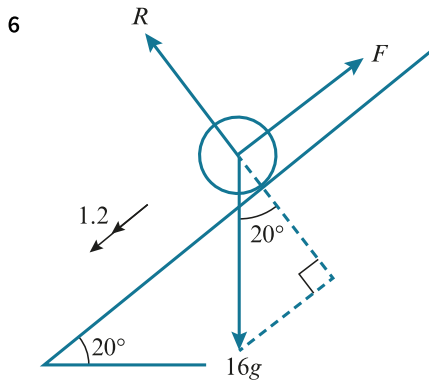

✓

Resultant force = ma

$$16g \sin 20^\circ - F = 16(1.2)$$

$$F = 160 \sin 20^\circ - 19.2$$

↙

$$R = 16g \cos 20^\circ$$

$$\mu = \frac{F}{R} = \frac{160 \sin 20^\circ - 19.2}{160 \cos 20^\circ} = 0.236$$

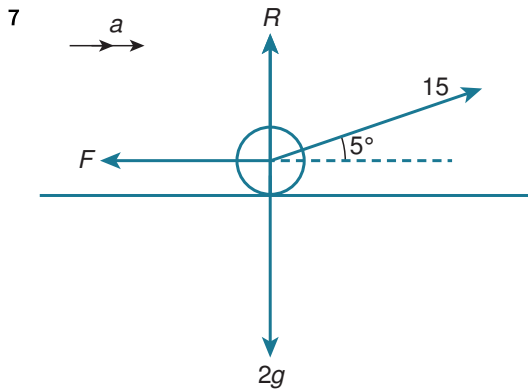

We know that R acts upwards because $15 \sin 5 < 2g$. Always think carefully about the relative sizes of forces. Decisions about this kind of thing will mean that your diagram has a better chance of being helpful!

↑

$$R + 15 \sin 5^\circ = 2g$$

$$R = 2g - 15 \sin 5^\circ$$

$$F = 0.4(2g - 15 \sin 5^\circ)$$

→

Resultant force = ma

$$15 \cos 5^\circ - 0.4(2g - 15 \sin 5^\circ) = 2a$$

$$a = 3.73 \text{ m s}^{-2}$$

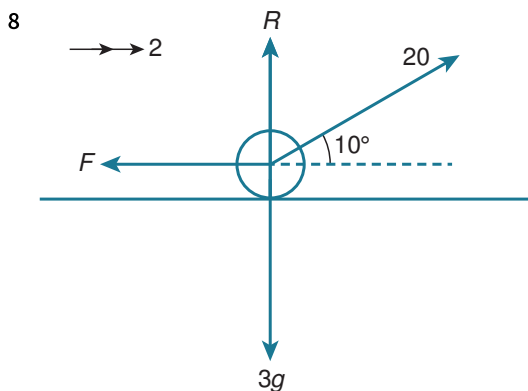

↑

$$20 \sin 10^\circ + R = 3g$$

$$R = 3g - 20 \sin 10^\circ$$

→

Resultant force = ma

$$20 \cos 10^\circ - F = 3(2)$$

$$F = 20 \cos 10^\circ - 6$$

$$\mu = \frac{F}{R} = \frac{20 \cos 10^\circ - 6}{3g - 20 \sin 10^\circ} = 0.516$$

9

Sometimes questions require you to work out maximum or minimum values of quantities necessary for a particular situation to occur. In such questions you need to assume that the extreme situation has happened and work from there. For example, in this question you need to work out the maximum coefficient of friction. To do this, assume that the plane only just makes it off the ground at the end of the runway.

Assuming the ski plane only just makes it off the ground at the end of the runway.

$$u = 0$$

$$v = 25$$

$$s = 600$$

$$a = ?$$

$$v^2 = u^2 + 2as$$

$$a = \frac{25^2 - 0^2}{1200} = \frac{25}{48}$$

→

$$16000 - F = 5000 \left(\frac{25}{48} \right), F = 13395.833\dots$$

↑

$$R = 5000g$$

$$\mu = \frac{F}{R} = \frac{13395.833\dots}{5000g} = 0.268$$

10

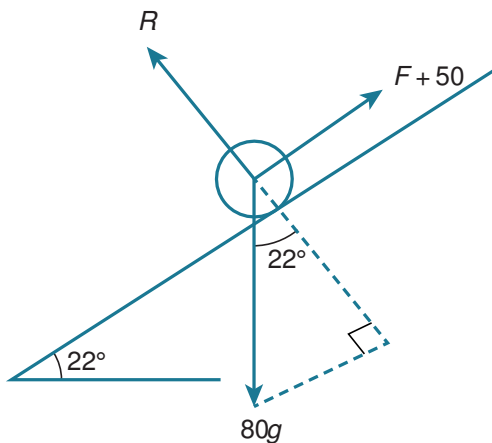

↖

$$R = 80g \cos 22^\circ$$

$$F = 0.3(80g \cos 22^\circ)$$

$$= 240 \cos 22^\circ$$

↙

Resultant force = ma

$$80g \sin 22^\circ - 240 \cos 22^\circ - 50 = 80a$$

$$a = 0.3395\dots \text{m s}^{-2}$$

$$s = 400$$

$$u = 20$$

$$v = ?$$

$$v^2 = u^2 + 2as$$

$$v = 25.9 \text{ m s}^{-1}$$

11

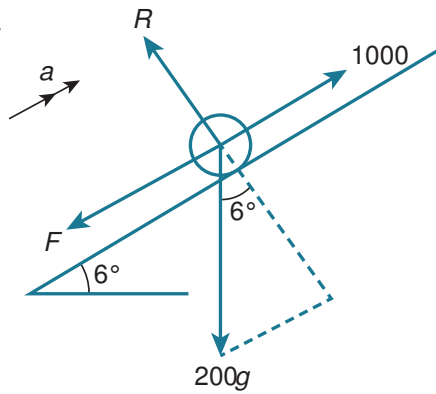

↗

Resultant force = ma

$$1000 - F - 200g \sin 6^\circ = 200a$$

↖

$$R = 200g \cos 6^\circ$$

$$F = 0.4(200g \cos 6^\circ)$$

$$= 800 \cos 6^\circ$$

$$\frac{1000 - 800 \cos 6^\circ - 200g \sin 6^\circ}{200} = a$$

$$a = -0.0233722\dots$$

$$u = 2$$

$$v = 1.5$$

$$s = ?$$

$$v^2 = u^2 + 2as$$

$$s = \frac{v^2 - u^2}{2a} = \frac{1.5^2 - 2^2}{2a} = 37.4 \text{ m}$$

12 Pushing:

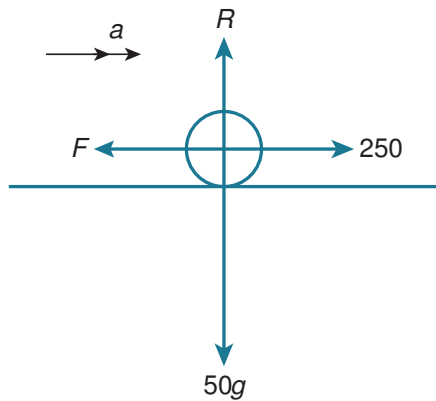

↑

$$R = 50g$$

→

$$250 - F = 50a$$

$$a = \frac{250 - 0.45(50g)}{50} = 0.5 \text{ m s}^{-2}$$

When directions change in the middle of a question, it is often necessary to re-draw the diagram to avoid confusion.

Pulling:

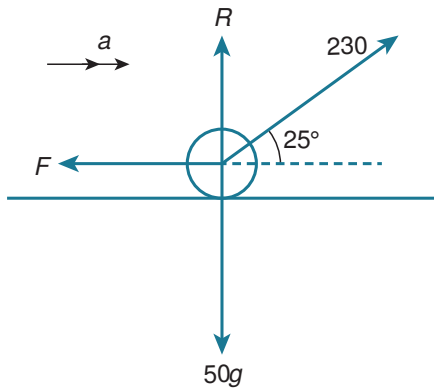

$$\begin{aligned} \uparrow \\ R + 230 \sin 25^\circ &= 50g \\ R &= 50g - 230 \sin 25^\circ \\ F &= 0.45(50g - 230 \sin 25^\circ) \end{aligned}$$

$$\begin{aligned} \rightarrow \\ \text{Resultant force} &= ma \\ 230 \cos 25^\circ - 0.45(50g - 230 \sin 25^\circ) &= 50a \\ a &= 0.544 \text{ m s}^{-2} \end{aligned}$$

Pulling gives a higher acceleration.

13 a

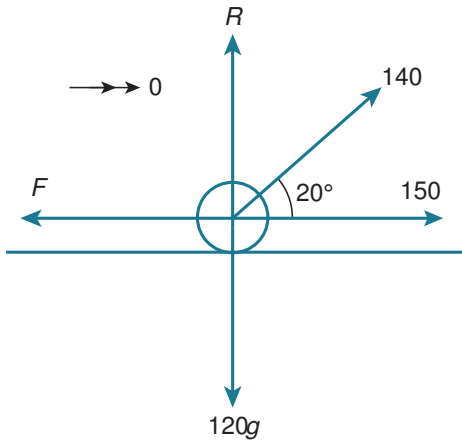

$$\begin{aligned} \uparrow \\ R + 140 \sin 20^\circ &= 120g \\ R &= 120g - 140 \sin 20^\circ \end{aligned}$$

$$\begin{aligned} \rightarrow \\ 140 \cos 20^\circ + 150 &= F \\ \mu &= \frac{F}{R} = \frac{140 \cos 20^\circ + 150}{120g - 140 \sin 20^\circ} = 0.244 \end{aligned}$$

Remember that a constant speed can only occur if forces are in equilibrium.

b

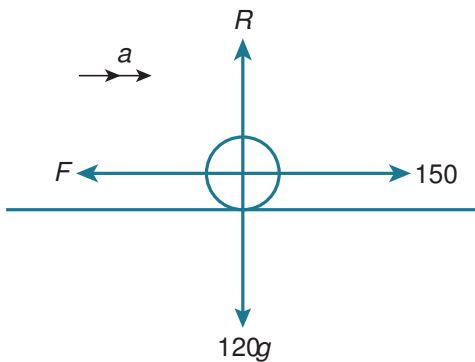

↑

$$R = 120g$$

$$F = 0.244(120g)$$

→

Resultant force = ma

$$150 - F = 120a$$

$$a = \frac{150 - 0.244(120g)}{120} = -1.19$$

$$\text{Deceleration} = 1.19 \text{ m s}^{-2}$$

14 ↑

$$R = 0.4g$$

$$F = 0.3(0.4g)$$

$$= 0.12g$$

$$= 1.2 \text{ N}$$

Before hitting the cushion:

→

Resultant force = ma

$$-1.2 = 0.4a$$

$$a = -3 \text{ m s}^{-2}$$

$$u = 3$$

$$s = 0.8$$

$$v = ?$$

$$v^2 = u^2 + 2as$$

$$v = \sqrt{4.2}$$

After the collision:

$$u = 0.8\sqrt{4.2}$$

$$v = 0$$

$$a = -3$$

$$s = ?$$

$$v^2 = u^2 + 2as$$

$$s = \frac{v^2 - u^2}{2a} = \frac{0 - 0.8^2(4.2)}{-6} = 0.448 \text{ m}$$

15 a

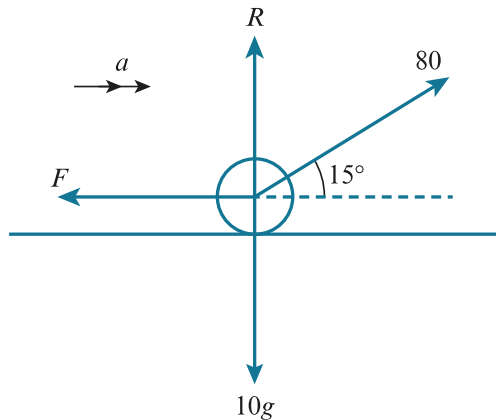

↑

$$R + 80 \sin 15^\circ = 10g$$

$$R = 10g - 80 \sin 15^\circ$$

$$F = 0.6(10g - 80 \sin 15^\circ)$$

→

Resultant force = ma

$$80 \cos 15^\circ - 0.6(10g - 80 \sin 15^\circ) = 10a$$

$$a = 2.97 \text{ m s}^{-2}$$

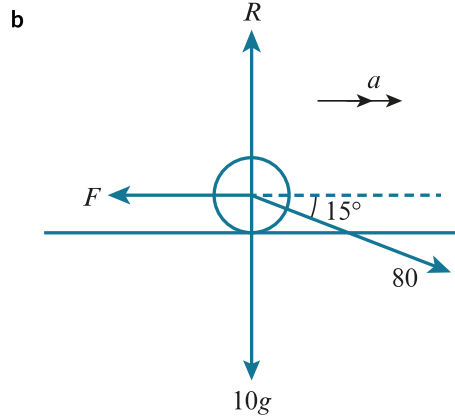

↑

$$R = 10g + 80 \sin 15^\circ$$

$$F = 0.6(10g + 80 \sin 15^\circ)$$

→

Resultant force = ma

$$80 \cos 15^\circ - 0.6(10g + 80 \sin 15^\circ) = 10a$$

$$a = 0.485 \text{ m s}^{-2}$$

16 a ↑

$$R = 50g$$

$$F = 0.3(50g) = 150 \text{ N}$$

→

Resultant force = ma

$$-150 - 25 = 50a$$

$$\text{Before string breaks: } a = \frac{-150 - 25}{50} = -3.5 \text{ m s}^{-2}$$

$$\text{After the string breaks: } a = \frac{-150 - 0}{50} = -3 \text{ m s}^{-2}$$

At the point of breaking:

$$u = 10$$

$$v = ?$$

$$a = -3.5$$

$$s = x$$

$$v^2 = u^2 + 2as$$

$$v^2 = 100 - 7x$$

At the point of halting:

$$v = 0$$

$$u = \sqrt{100 - 7x}$$

Distance remaining = $14.5 - x$

$$a = -3$$

$$v^2 = u^2 + 2as$$

$$0 = 100 - 7x - 6(14.5 - x)$$

$$x = 13 \text{ m}$$

b We assume that the tension drops to zero immediately.

EXERCISE 4C

1

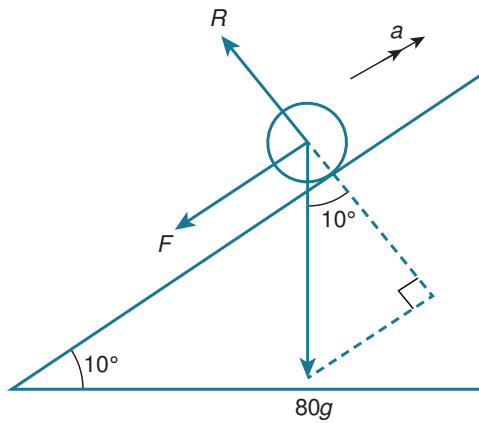

$$\begin{aligned} R &= 80g \cos 10^\circ \\ F &= 0.4(80g \cos 10^\circ) \\ &= 320 \cos 10^\circ \end{aligned}$$

$$\text{Resultant force} = ma$$

$$\begin{aligned} -80g \sin 10^\circ - 320 \cos 10^\circ &= 80a \\ a &= -g \sin 10^\circ - 4 \cos 10^\circ \end{aligned}$$

$$u = 12$$

$$v = 0$$

$$s = ?$$

$$v^2 = u^2 + 2as$$

$$s = \frac{v^2 - u^2}{2a} = \frac{0 - 12^2}{2a} = 12.7 \text{ m}$$

$$F_{\max} = 320 \cos 10^\circ = 315.1 \text{ N}$$

Component of weight down the slope

$$80g \sin 10^\circ = 138.9 < 315.1$$

Weight cannot overcome the friction and the object remains at rest.

2

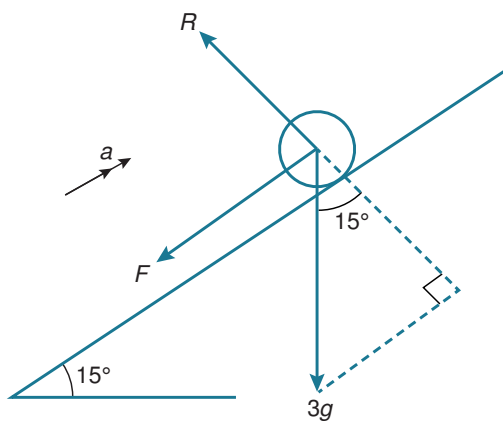

$$\begin{aligned} R &= 3g \cos 15^\circ \\ F &= 0.6(3g \cos 15^\circ) \\ &= 18 \cos 15^\circ \end{aligned}$$

Resultant force = ma

$$-F - 3g \sin 15^\circ = 3a$$

$$-18 \cos 15^\circ - 3g \sin 15^\circ = 3a$$

$$a = -8.3837\dots$$

$$u = 8$$

$$v = 0$$

$$t = ?$$

$$v = u + at$$

$$t = \frac{v - u}{a} = \frac{0 - 8}{-8.3837\dots} = 0.9542\dots$$

$$F_{\max} = 18 \cos 15^\circ = 17.39$$

Weight down the slope

$$= 3g \sin 15^\circ = 7.76 < 17.39$$

The component of weight acting down the slope is not sufficient to overcome friction, so the object does not move again.

- b If the ball were not a particle it would roll rather than slide.

Notice how the assumptions start to change once friction and other resistances have been introduced. Instead of simply 'no air resistance', which is common in early topics, we now shift to thinking about the actual shape of an object.

3

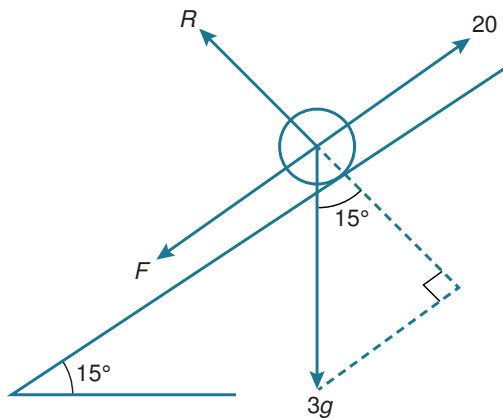

a ↙

$$R = 3g \cos 15^\circ$$

$$F = \mu(3g \cos 15^\circ)$$

↗

$$20 = 3g \sin 15^\circ + F$$

$$20 = 3g \sin 15^\circ + \mu(3g \cos 15^\circ)$$

$$\mu = \frac{20 - 3g \sin 15^\circ}{3g \cos 15^\circ} = 0.422$$

b

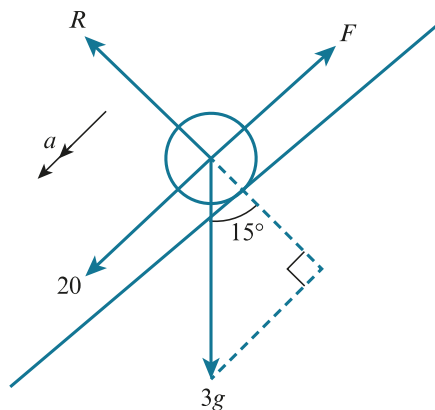

If any changes to the situation happen parallel to the slope – as here, where the object simply changes direction – then the normal contact force will remain unchanged.

R is unchanged, $R = 30 \cos 15^\circ$

✓

Resultant force = ma

$$20 - F + 3g \sin 15^\circ = 3a$$

$$20 - \mu(30 \cos 15^\circ) + 3g \sin 15^\circ = 3a$$

$$a = 5.18 \text{ m s}^{-2}$$

4 a

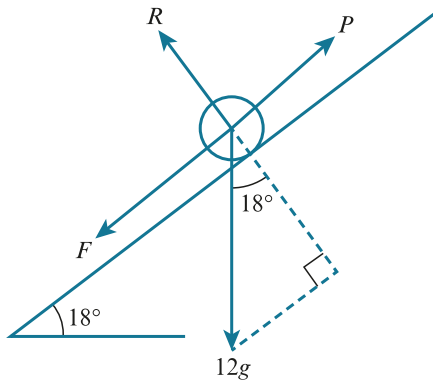

Assume limiting equilibrium

↖

$$R = 12g \cos 18^\circ$$

$$F = 0.4(12g \cos 18^\circ)$$

$$= 48 \cos 18^\circ$$

↗

$$P = F + 12g \sin 18^\circ$$

$$= 48 \cos 18^\circ + 120 \sin 18^\circ$$

$$= 82.7 \text{ N}$$

b

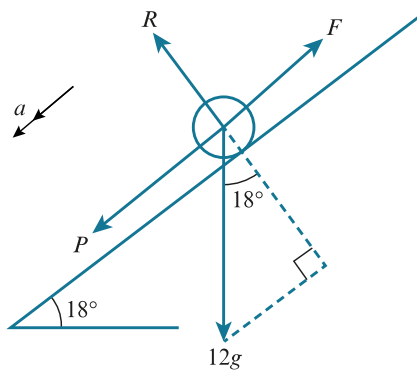

↖

$$R = 12g \cos 18^\circ$$

$$= 120 \cos 18^\circ$$

✓

Resultant force = ma

$$12g \sin 18^\circ + P - F = 12a$$

$$a = \frac{12g \sin 18^\circ + 82.7 \dots - 48 \cos 18^\circ}{12}$$

$$= 6.18 \text{ m s}^{-2}$$

5

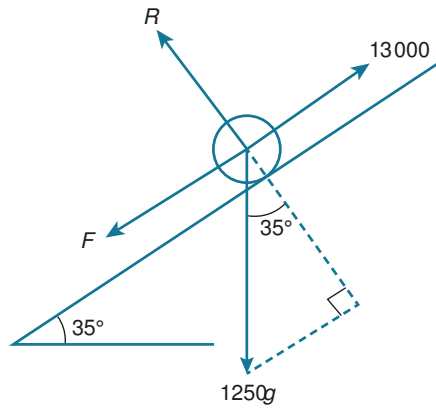

Assume that equilibrium is about to be broken:



$$13000 = F_{\max} + 1250g \sin 35^\circ$$

$$F_{\max} = 13000 - 1250g \sin 35^\circ = 5830.29 \dots$$

Component of weight down the slope

$$= 1250g \sin 25^\circ$$

$$= 7169.705 > F_{\max}$$

So the object slides.

Additional force required to hold in place

$$= 7169.705 - 5830.29$$

$$= 1340 \text{ N}$$

6

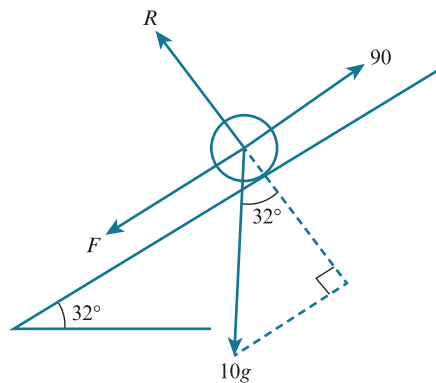

The object is 'on the point of moving up'. This means that equilibrium is about to be broken and friction takes its maximum value.



$$90 = F_{\max} + 10g \sin 32^\circ$$

$$F_{\max} = 90 - 10g \sin 32^\circ = 37.0 \text{ N}$$

If the force is now removed, the bin tries to slide down and friction changes to the opposite direction.

Component of weight down the slope

$$= 10g \sin 32^\circ = 52.99 \text{ N} > F_{\max}$$

The bin slides.



Resultant force = ma

$$10 \sin 32^\circ - (90 - 10g \sin 32^\circ) = 10a$$

$$a = 1.60 \text{ m s}^{-2}$$

7

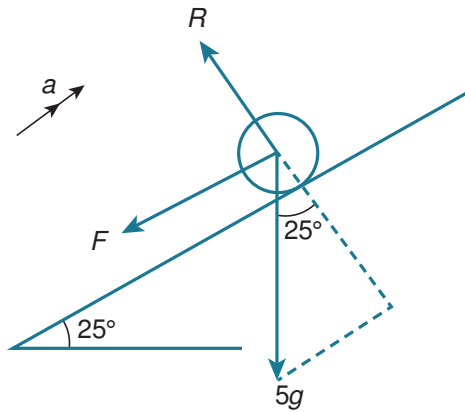

↙

$$R = 5g \cos 25^\circ$$

$$F = 0.4(5g \cos 25^\circ)$$

$$= 20 \cos 25^\circ$$

↗

Resultant force = ma

$$-F - 5g \sin 25^\circ = 5a$$

$$a = \frac{-20 \cos 25^\circ - 50 \sin 25^\circ}{5}$$

$$= -4 \cos 25^\circ - 10 \sin 25^\circ$$

$$u = 12$$

$$s = ?$$

$$v = 0$$

$$v^2 = u^2 + 2as$$

$$s = \frac{-144}{2a} = 9.17 \dots$$

Coming down:

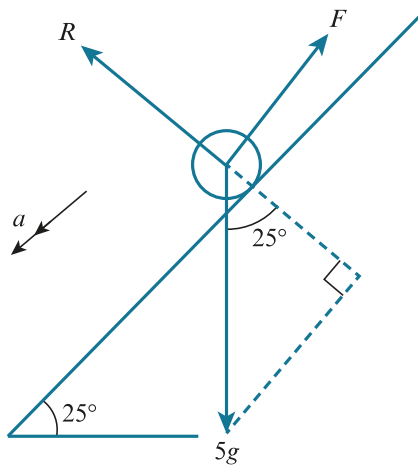

↙

Resultant force = ma

$$5g \sin 25^\circ - F = 5a$$

$$a = \frac{5g \sin 25^\circ - 20 \cos 25^\circ}{5}$$

$$u = 0$$

$$v = ?$$

$$s = 9.17 \dots$$

$$v^2 = u^2 + 2as$$

$$v = 3.32 \text{ m s}^{-1}$$

8 Going up:

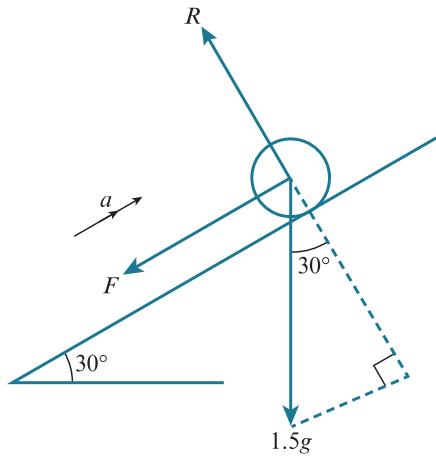

$$R = 1.5g \cos 30^\circ$$

$$F = 6.75 \cos 30$$

Resultant force = ma

$$-F - 1.5g \sin 30^\circ = 1.5a$$

$$a = \frac{-6.75 \cos 30 - 15 \sin 30^\circ}{1.5}$$

$$= -8.897\dots$$

$$u = 10$$

$$v = 0$$

$$s = ?$$

$$v^2 = u^2 + 2as$$

$$s = \frac{v^2 - u^2}{2a} = \frac{0 - 100}{2(-8.897\dots)} = 5.619\dots$$

$$v = u + at$$

$$t = \frac{v - u}{a} = \frac{0 - 10}{-8.897\dots} = 1.123\dots$$

Coming down:

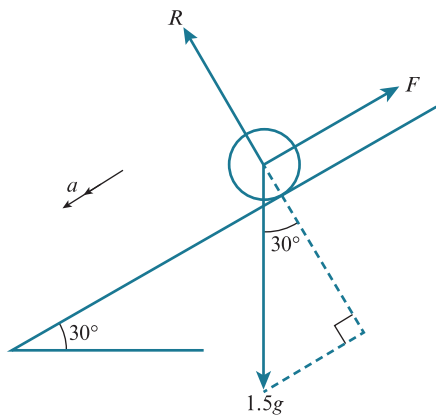

Resultant force = ma

$$1.5g \sin 30^\circ - 6.75 \cos 30 = 1.5a$$

$$a = 1.10\dots$$

$$u = 0$$

$$s = 5.619\dots$$

$$t = ?$$

$$a = 1.10\dots$$

$$s = ut + \frac{1}{2}at^2$$

$$5.619... = 0 + \frac{1}{2}(1.10...)t^2$$

$$t = 3.19.....$$

$$\text{Total} = 3.19.... + 1.123... = 4.32\text{s}$$

9 a

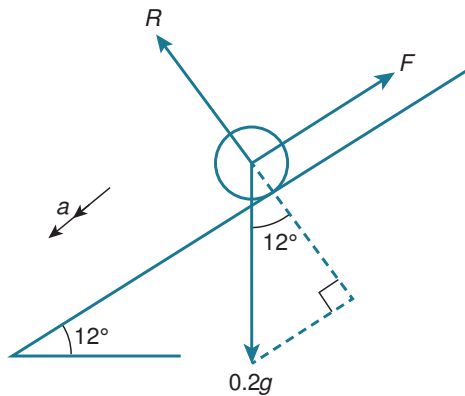

↙

$$R = 0.2g \cos 12^\circ$$

$$F = 0.1(0.2g \cos 12^\circ)$$

$$= 0.2 \cos 12^\circ$$

↘

$$\text{Resultant force} = ma$$

$$0.2g \sin 12^\circ - F = 0.2a$$

$$a = 10 \sin 12^\circ - \cos 12^\circ$$

On impact:

$$u = 0$$

$$v = ?$$

$$s = 1.2$$

$$a = 10 \sin 12^\circ - \cos 12^\circ$$

$$v^2 = u^2 + 2as$$

$$v = \sqrt{0 + 2(10 \sin 12^\circ - \cos 12^\circ)(1.2)} = 1.625...$$

Rebound speed

$$= 1.5 \times 1.625... = 2.438...$$

Remember that to increase by 50% you need 150% of the original. So multiply by 1.5.

On the way up:

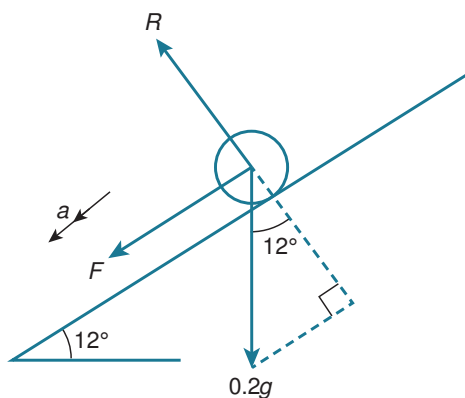

↗

$$\text{Resultant force} = ma$$

$$-F - 0.2g \sin 12^\circ = 0.2a$$

$$a = -\cos 12^\circ - 10 \sin 12^\circ$$

$$u = 2.438\dots$$

$$v = 0$$

$$s = ?$$

$$v^2 = u^2 + 2as$$

$$s = \frac{v^2 - u^2}{2a} = 0.972 \text{ m}$$

- b** The ball is being modelled as a particle, so slides rather than rolls and has no thickness, so the size of the ball does not affect the height reached up the slope.

10 Going up:

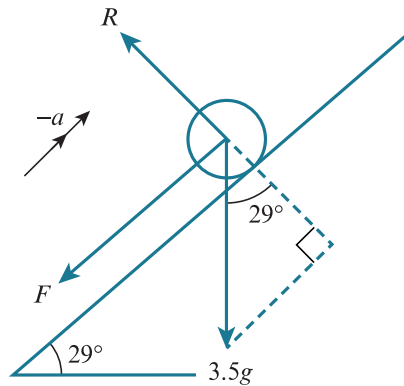

$$u = 20$$

$$v = 0$$

$$s = 25$$

$$a = ?$$

$$v^2 = u^2 + 2as$$

$$a = \frac{0 - 20^2}{50} = -8 \text{ m s}^{-2}$$

↗

Resultant force = ma

$$-F - 3.5g \sin 29^\circ = 3.5(-8)$$

$$F = 28 - 35 \sin 29^\circ$$

Coming down:

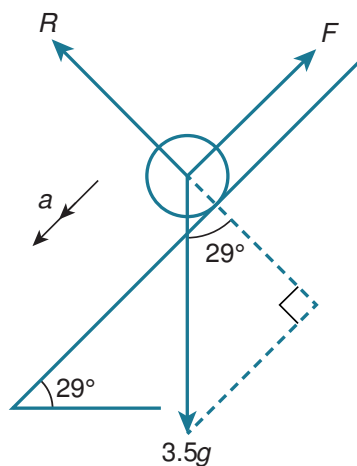

$$3.5g \sin 29^\circ - (28 - 35 \sin 29^\circ) = 3.5a$$

$$a = 10 \sin 29^\circ - (8 - 10 \sin 29^\circ)$$

$$= 20 \sin 29^\circ - 8$$

$$u = 0$$

$$v = ?$$

$$s = 25$$

$$v^2 = u^2 + 2as$$

$$v = \sqrt{0 + 2(20 \sin 29^\circ - 8)(25)}$$

$$= 9.21 \text{ m s}^{-1}$$

11

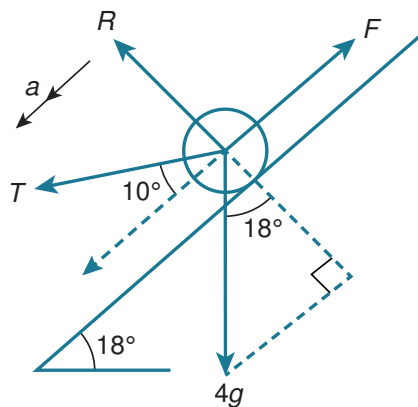

$$R + T \sin 10^\circ = 4g \cos 18^\circ$$

$$R = 4g \cos 18^\circ - T \sin 10^\circ$$

$$F = 0.4(4g \cos 18^\circ - T \sin 10^\circ)$$



$$T \cos 10^\circ + 4g \sin 18^\circ - 0.4(4g \cos 18^\circ - T \sin 10^\circ) = 4a$$

String attached gives $T = 8$

$$a = 1.394477\dots$$

When detached $T = 0$

$$a = 10 \sin 18^\circ - 4 \cos 18^\circ = -0.71405\dots$$

When attached:

$$u = 0$$

$$v = ?$$

$$t = 3$$

$$a = 1.394477\dots$$

$$v = u + at$$

$$v = 4.1834\dots \text{ m s}^{-1}$$

Distance:

$$u = 0$$

$$t = 3$$

$$a = 1.394477\dots$$

$$s = ?$$

$$s = ut + \frac{1}{2}at^2$$

$$s = 0 + \frac{1}{2}a(9) = 6.2752\dots \text{ m}$$

When detached:

$$u = 4.1834\dots$$

$$a = -0.71405\dots$$

$$s = ?$$

$$v = 0$$

$$v^2 = u^2 + 2as$$

$$s = \frac{0 - 4.1834\dots^2}{2a} = 12.25\dots \text{ m}$$

Total distance = $12.25\dots + 6.275\dots$

$$= 18.5 \text{ m}$$

12

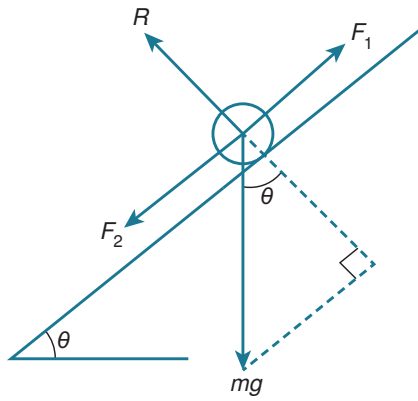

$$R = mg \cos 34^\circ$$

Going up:

$$F_1 = \mu R = \mu mg \cos 34^\circ$$

$$F_2 = 0$$

Resultant force = ma

$$-mg \sin 34^\circ - \mu mg \cos 34^\circ = ma$$

$$\text{So } a = -g(\sin 34^\circ + \mu \cos 34^\circ)$$

$$u = 3$$

$$v = 0$$

$$s = ?$$

$$v^2 = u^2 + 2as$$

$$s = \frac{0 - 9}{-2g(\sin 34^\circ + \mu \cos 34^\circ)}$$

$$= \frac{9}{2g(\sin 34^\circ + \mu \cos 34^\circ)}$$

Going down:

$$F_1 = 0$$

$$F_2 = \mu R = \mu mg \cos 34^\circ$$

Resultant force = ma

$$mg \sin 34^\circ - \mu mg \cos 34^\circ = ma$$

$$\text{So } a = g \sin 34^\circ - \mu g \cos 34^\circ$$

$$u = 0$$

$$v = 2$$

$$s = \frac{9}{2g(\sin 34^\circ + \mu \cos 34^\circ)}$$

$$v^2 = u^2 + 2as$$

$$4 = 0 + \frac{18g(\sin 34^\circ - \mu \cos 34^\circ)}{2g(\sin 34^\circ + \mu \cos 34^\circ)}$$

$$= \frac{9(\sin 34^\circ - \mu \cos 34^\circ)}{(\sin 34^\circ + \mu \cos 34^\circ)}$$

$$4 \sin 34^\circ + 4\mu \cos 34^\circ = 9 \sin 34^\circ - 9\mu \cos 34^\circ$$

$$13\mu \cos 34^\circ = 5 \sin 34^\circ$$

$$\mu = \frac{5}{13} \tan^{-1} 34^\circ$$

$$= 0.259$$

13

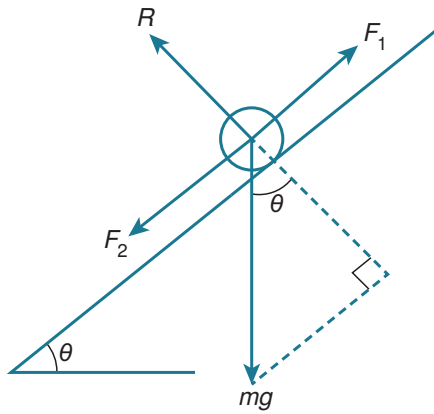

↖

$$R = mg \cos \theta$$

Travelling up:

$$F_2 = F_{\max} = \mu mg \cos \theta$$

$$F_1 = 0$$

Travelling down:

$$F_2 = 0$$

$$F_1 = F_{\max} = \mu mg \cos \theta$$

Up:

↗

Resultant force = ma

$$-F_2 - mg \sin \theta = ma$$

$$a = -\mu g \cos \theta - g \sin \theta$$

$$v^2 = u^2 + 2as$$

$$0 = u^2 + 2(-\mu g \cos \theta - g \sin \theta)s$$

$$s = \frac{u^2}{2g \sin \theta + 2\mu g \cos \theta}$$

Down:

↙

Resultant force = ma

$$mg \sin \theta - F_1 = ma$$

$$a = g \sin \theta - \mu g \cos \theta$$

$$u = 0$$

$$v = ?$$

$$s = \frac{u^2}{2g(\sin \theta + \mu \cos \theta)}$$

$$v^2 = u^2 + 2as$$

$$v^2 = 0 + 2g(\sin \theta - \mu \cos \theta) \left(\frac{u^2}{2g(\sin \theta + \mu \cos \theta)} \right)$$

$$v^2 = u^2 \left(\frac{\sin \theta - \mu \cos \theta}{\sin \theta + \mu \cos \theta} \right)$$

 θ is acute, so $\cos \theta > 0$

$$\sin \theta - \mu \cos \theta < \sin \theta + \mu \cos \theta$$

$$\frac{\sin \theta - \mu \cos \theta}{\sin \theta + \mu \cos \theta} < 1$$

$$v^2 < u^2$$

$$v < u$$

14

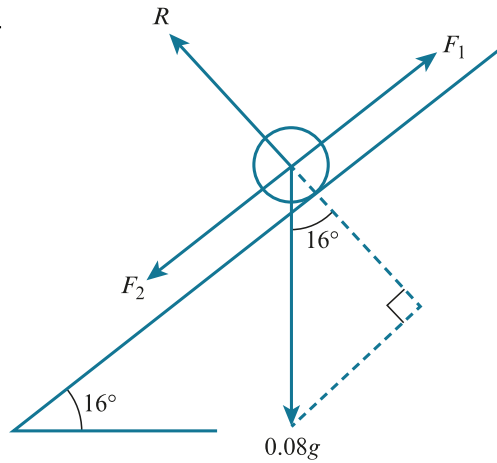

↙

$$R = 0.08g \cos 16^\circ$$

$$= 0.8 \cos 16^\circ$$

$$F_{\max} = 0.8\mu \cos 16^\circ$$

Down:

↘

Resultant force = ma

$$0.08g \sin 16^\circ - 0.8\mu \cos 16^\circ = 0.08a$$

$$a = g \sin 16^\circ - 10\mu \cos 16^\circ$$

$$u = 0$$

$$v = ?$$

$$s = 0.8$$

$$v^2 = u^2 + 2as$$

$$v = \sqrt{0 + 2(g \sin 16^\circ - 10\mu \cos 16^\circ)(0.8)}$$

$$= \sqrt{16(\sin 16^\circ - \mu \cos 16^\circ)}$$

Moving upwards:

↗

Resultant force = ma

$$-0.08g \sin 16^\circ - 0.8\mu \cos 16^\circ = 0.08a$$

$$a = -g \sin 16^\circ - 10\mu \cos 16^\circ$$

Rebound speed

$$= \frac{1}{2} \sqrt{16(\sin 16^\circ - \mu \cos 16^\circ)}$$

$$v = 0$$

$$s = 0.1$$

$$v^2 = u^2 + 2as$$

$$0 = \frac{1}{4} \{16(\sin 16^\circ - \mu \cos 16^\circ)\} + 2 \{-g \sin 16^\circ - 10\mu \cos 16^\circ\} (0.1)$$

$$4(\sin 16^\circ - \mu \cos 16^\circ) = 2 \sin 16^\circ + 2\mu \cos 16^\circ$$

$$2 \sin 16^\circ = 6\mu \cos 16^\circ$$

$$\mu = \frac{2 \sin 16^\circ}{6 \cos 16^\circ} = 0.0956$$

E EXERCISE 4D

1

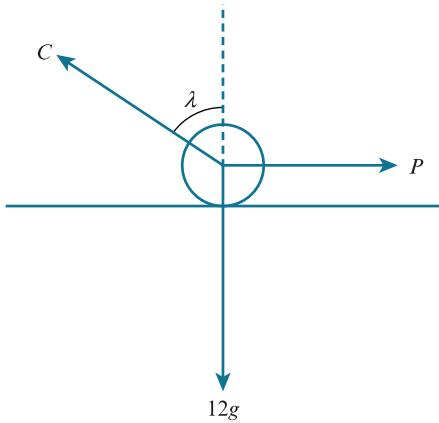

Throughout this exercise it is important to note that $\sin(90^\circ + a) = \cos a$ and $\sin(180 - a) = \sin a$.

$$\begin{aligned} \tan \lambda &= 0.4 \\ \frac{P}{\sin(180^\circ - \lambda)} &= \frac{12g}{\sin(90^\circ + \lambda)} \\ P &= \frac{12g \sin(180^\circ - \lambda)}{\sin(90^\circ + \lambda)} \\ &= \frac{12g \sin \lambda}{\cos \lambda} \\ &= 12g \tan \lambda \\ &= 120(0.4) \\ &= 48 \text{ N} \end{aligned}$$

2

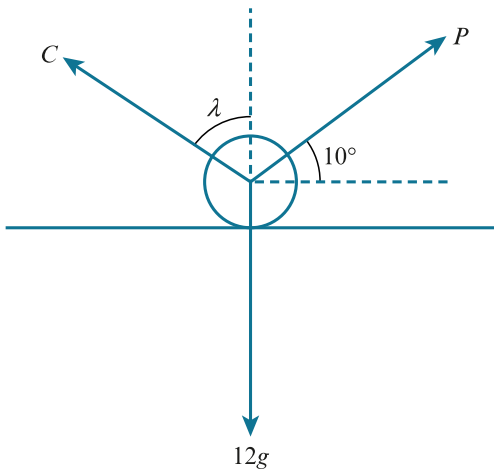

$$\tan \lambda = 0.4 = \frac{2}{5}$$

Although you can use right-angled triangles to find exact sine and cosine ratios from this, you do not need to.

$$\begin{aligned} \frac{P}{\sin(180^\circ - \lambda)} &= \frac{12g}{\sin(80^\circ + \lambda)} \\ P &= \frac{12g \sin \lambda}{\sin(80^\circ + \lambda)} \\ \lambda &= \tan^{-1} 0.4 \\ P &= \frac{120 \sin(\tan^{-1} 0.4)}{\sin(80^\circ + \tan^{-1} 0.4)} \\ &= 45.5 \text{ N} \end{aligned}$$

3

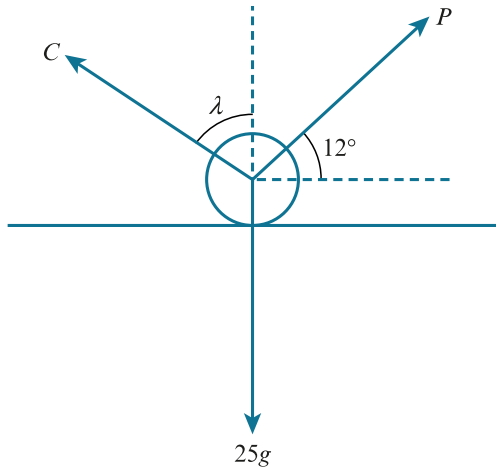

$$\begin{aligned} \tan \lambda &= 0.5 \\ \frac{C}{\sin 102^\circ} &= \frac{25g}{\sin(\lambda + 78^\circ)} \\ C &= \frac{25g \sin 102^\circ}{\sin(\lambda + 78^\circ)} \\ &= \frac{250 \sin 102^\circ}{\sin(\tan^{-1} 0.5 + 78^\circ)} \\ &= 253 \text{ N} \end{aligned}$$

4 a

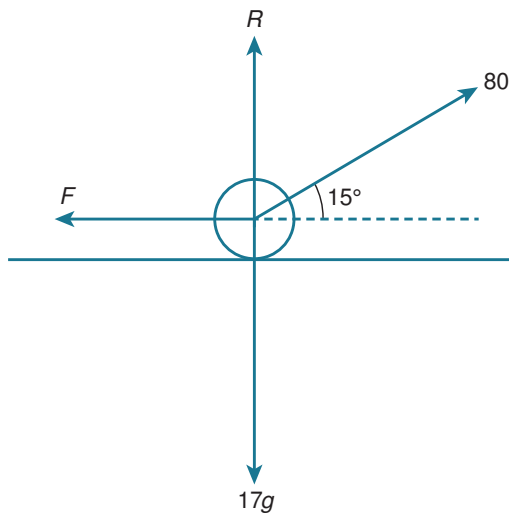

$$\begin{aligned} \uparrow \\ R + 80 \sin 15^\circ &= 17g \\ R &= 17g - 80 \sin 15^\circ \end{aligned}$$

$$\begin{aligned} \leftarrow \\ F &= 80 \cos 15^\circ \end{aligned}$$

Remember that the angle of friction is the angle with the normal contact force and not the angle with the slope.

$$\lambda = \tan^{-1} \left(\frac{80 \cos 15^\circ}{17g - 80 \sin 15^\circ} \right) = 27.4^\circ$$

b $\mu = \tan \lambda = 0.518$

5

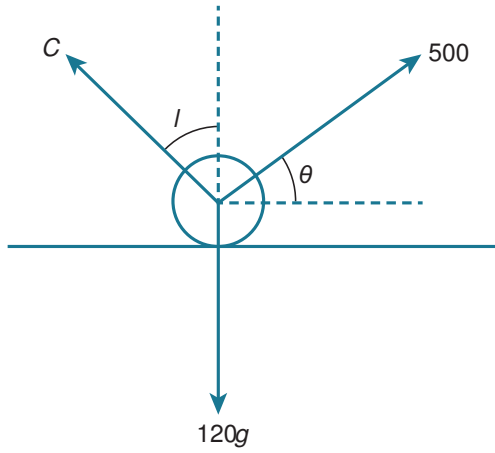

$$\tan \lambda = 0.45$$

$$\sin \lambda = \frac{9}{\sqrt{481}}$$

$$\frac{500}{\sin(180^\circ - \lambda)} = \frac{120g}{\sin(\lambda + 90^\circ - \theta)}$$

$$\frac{500}{\sin \lambda} = \frac{120g}{\cos(\lambda - \theta)}$$

$$500 \cos(\lambda - \theta) = 1200 \sin \lambda$$

$$\cos(\lambda - \theta) = \frac{10800}{500\sqrt{481}}$$

$$\lambda - \theta = 9.97777\dots$$

$$\theta = \lambda - 9.9777\dots = 14.3^\circ$$

6

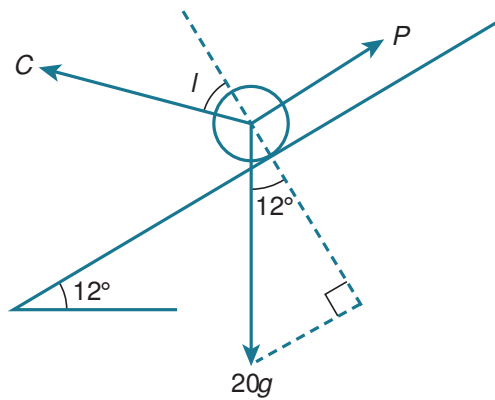

$$\tan \lambda = 0.4$$

$$\frac{P}{\sin(180^\circ - \lambda - 12^\circ)} = \frac{20g}{\sin(90^\circ + \lambda)}$$

$$P = \frac{200 \sin(168^\circ - \lambda)}{\cos \lambda}$$

Substituting $\lambda = \tan^{-1}0.4$

$$P = 120 \text{ N}$$

There is no point in expanding the numerator of $P = \frac{200 \sin(168^\circ - \lambda)}{\cos \lambda}$ because the outcome will involve sines and cosines of 168° . Sines and cosines of 168° will be non-recurring decimals.

7

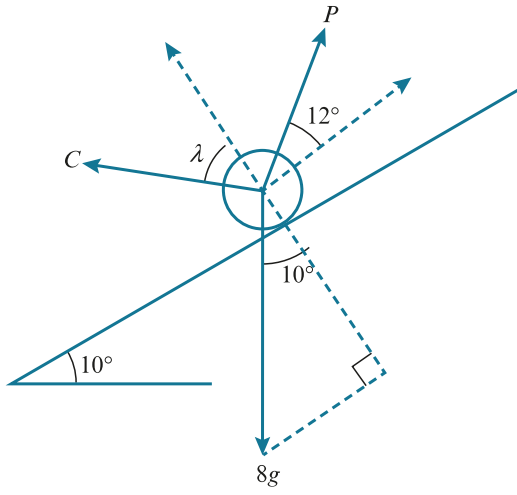

$$\tan \lambda = 0.3$$

$$\frac{P}{\sin(170^\circ - \lambda)} = \frac{8g}{\sin(78^\circ + \lambda)}$$

$$P = \frac{80 \sin(170^\circ - \lambda)}{\sin(78^\circ + \lambda)}$$

$$\lambda = \tan^{-1}(0.3)$$

$$P = 36.1 \text{ N}$$

8

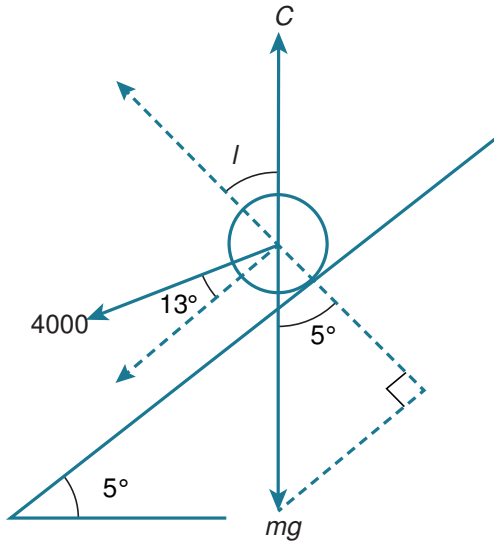

$$\frac{mg}{\sin(77^\circ + \lambda)} = \frac{4000}{\sin(185^\circ - \lambda)}$$

$$m = \frac{4000 \sin(77^\circ + \lambda)}{g \sin(185^\circ - \lambda)}$$

$$\lambda = \tan^{-1}(0.35)$$

$$m = 1610 \text{ kg}$$

9

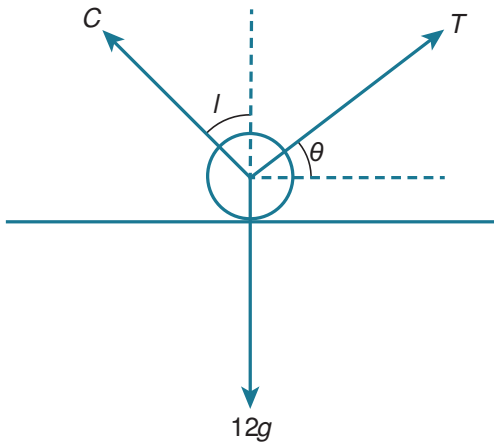

$$\tan \lambda = 0.6$$

$$\frac{T}{\sin(180^\circ - \lambda)} = \frac{12g}{\sin(\lambda + 90^\circ - \theta)}$$

$$T = \frac{12g \sin \lambda}{\cos(\lambda - \theta)}$$

Minimise T when $\cos(\lambda - \theta)$ is a maximum.

$$\cos(\lambda - \theta) = 1$$

$$\lambda - \theta = 0$$

$$\lambda = \theta$$

At the point where T is minimised:

$$T = \frac{12g \sin \lambda}{1}$$

$$= 120 \sin \lambda$$

$$= 61.7 \text{ N}$$

10

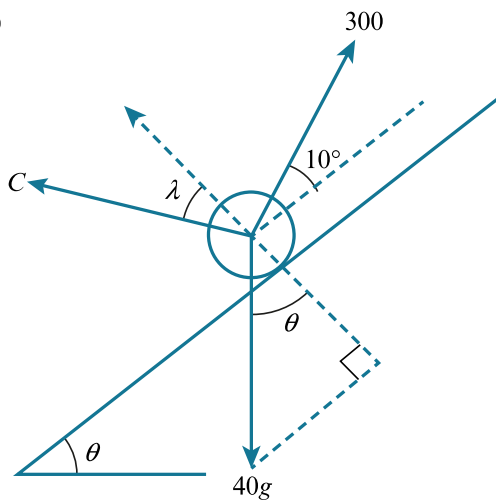

$$\frac{40g}{\sin(80^\circ + \lambda)} = \frac{300}{\sin(180^\circ - \theta - \lambda)}$$

$$\lambda = \tan^{-1} 0.3 = 16.6992$$

$$\sin(180^\circ - \theta - \lambda) = \frac{300 \sin(80^\circ + \lambda)}{400} = 0.745$$

$$180^\circ - \theta - \lambda = 48.148 \text{ or } 131.85$$

$$\theta = 115.2^\circ \text{ or } 31.5^\circ$$

$$\theta < 90^\circ$$

$$\theta = 31.5^\circ$$

Note that you need to consider more than one possible inverse sine value here. This is always a possibility when using Lami's Theorem. Remember the ambiguous case of the sine from Pure Mathematics!

11 If $T > \frac{mg \sin \theta}{\cos(\alpha - \theta)}$ the Lami's Theorem can't hold and equilibrium is not possible. So the ring always moves.

12 $\theta = \tan^{-1} \mu$ so θ is the angle between R and the total contact force C .

Going up the slope:

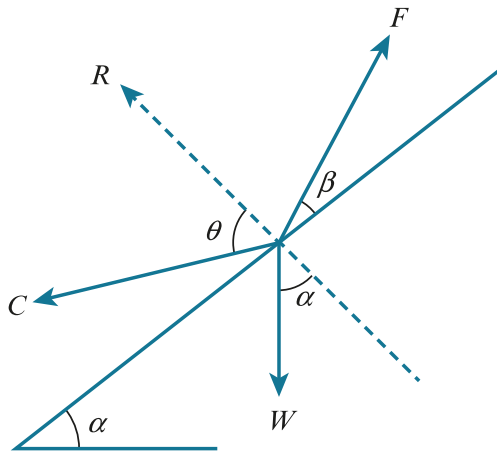

Using Lami's theorem:

$$\frac{F}{\sin(180^\circ - \alpha - \theta)} = \frac{W}{\sin(\theta + 90^\circ - \beta)}$$

Since $\theta + \alpha < 90^\circ$, $\sin(180^\circ - \alpha - \theta) = \sin(180^\circ - (\alpha + \theta)) = \sin(\alpha + \theta)$

$$\frac{F}{\sin(\alpha + \theta)} = \frac{W}{\sin(\theta + 90^\circ - \beta)}$$

$$F = \frac{W \sin(\alpha + \theta)}{\sin(\theta + 90^\circ - \beta)}$$

F takes its minimum value when $\sin(\theta + 90^\circ - \beta) = 1$, which happens when $\theta = \beta$.

So, the minimum force F required to break equilibrium is $W \sin(\alpha + \theta)$.

Going down the slope:

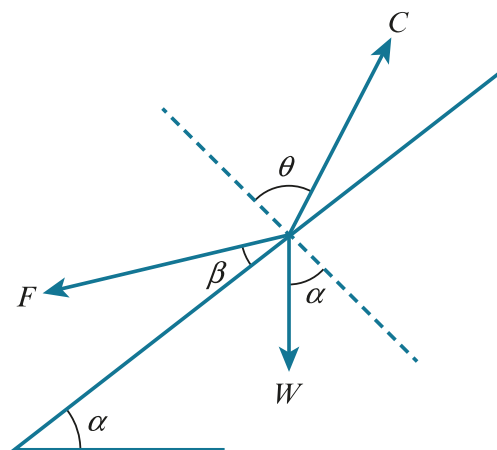

Using Lami's theorem:

$$\frac{F}{\sin(180^\circ - \theta + \alpha)} = \frac{W}{\sin(90^\circ - \beta + \theta)}$$

Since $\theta > \alpha$, $\sin(180^\circ - \theta + \alpha) = \sin(180^\circ - (\theta - \alpha)) = \sin(\theta - \alpha)$

$$\frac{F}{\sin(\theta - \alpha)} = \frac{W}{\sin(90^\circ - \beta + \theta)}$$

$$F = \frac{W \sin(\theta - \alpha)}{\sin(90^\circ - \beta + \theta)}$$

F takes its minimum value when $\sin(90^\circ - \beta + \theta) = 1$, which happens when $\theta = \beta$.

So, the minimum force F required to break equilibrium is $W \sin(\theta - \alpha)$.

END-OF-CHAPTER REVIEW EXERCISE 4

1 On the point of slipping

$$F = 0.35R$$

↑

$$R = 12g$$

$$F = 0.35(120) = 42$$

→

$$T = F = 42 \text{ N}$$

2

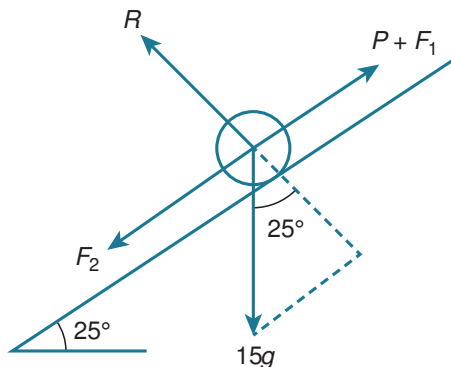

We write two friction forces on this diagram. If the particle is about to slip up the slope, then there is maximum friction down the slope and the upward friction is zero. The situation is reversed if the particle is about to slip down the slope. This approach makes it possible to use just one diagram.

↙

$$R = 15g \cos 25^\circ$$

$$F_{\max} = 0.3(15g \cos 25^\circ) = 45 \cos 25^\circ$$

About to slip up the slope:

↗

$$P = F_2 + 15g \sin 25^\circ$$

$$= 45 \cos 25^\circ + 150 \sin 25^\circ$$

$$= 104 \text{ N}$$

About to slip down the slope:

↙

$$15g \sin 25^\circ = P + F_1$$

$$150 \sin 25^\circ = P + 45 \cos 25^\circ$$

$$P = 150 \sin 25^\circ - 45 \cos 25^\circ$$

$$= 22.6 \text{ N}$$

$$22.6 \text{ N} < P < 104 \text{ N}$$

3 ↑

$$R = 4g = 40$$

$$F = 0.04(40) = 1.6$$

→

Resultant force = ma

$$-1.6 = 4a$$

$$a = -0.4 \text{ m s}^{-2}$$

$$u = 9$$

$$v = ?$$

$$s = 18.5$$

$$v^2 = u^2 + 2as$$

$$v = \sqrt{9^2 - 2(0.4)(18.5)}$$

$$= 8.14 \text{ m s}^{-1}$$

4

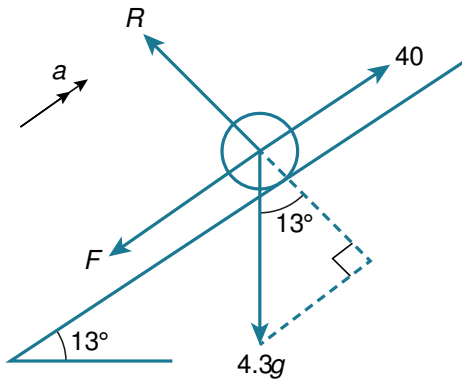

$$\begin{aligned} R &= 4.3g \cos 13^\circ \\ F &= 0.55(4.3g \cos 13^\circ) \end{aligned}$$

Resultant force = ma

$$\begin{aligned} 40 - 4.3g \sin 13^\circ - F &= 4.3a \\ 40 - 4.3g \sin 13^\circ - 0.55(4.3g \cos 13^\circ) &= 4.3a \\ a &= 1.69 \text{ m s}^{-2} \end{aligned}$$

5

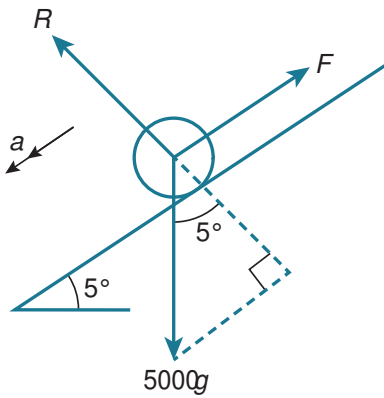

$$\begin{aligned} R &= 5000g \cos 5^\circ = 50000 \cos 5^\circ \\ F &= 0.08(50000 \cos 5^\circ) \\ &= 4000 \cos 5^\circ \end{aligned}$$

Resultant force = ma

$$\begin{aligned} 5000g \sin 5^\circ - 4000 \cos 5^\circ &= 5000a \\ a &= 10 \sin 5^\circ - 0.8 \cos 5^\circ \end{aligned}$$

$$u = 0$$

$$v = ?$$

$$s = 40$$

$$v^2 = u^2 + 2as$$

$$v = 2.44 \text{ m s}^{-1}$$

6

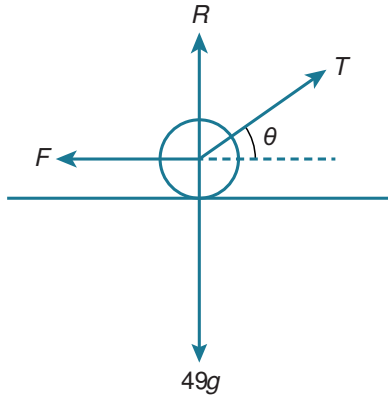

Remember that, for acute angles, it is possible to use Pythagoras' Theorem to 'convert' between exact sine, cosine and tangent ratios.

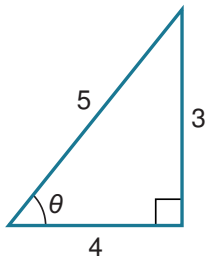

$$\sin \theta = \frac{3}{5} \quad \cos \theta = \frac{4}{5}$$

→

$$T \cos \theta = F = 0.3R$$

$$\frac{4}{5}T = \frac{3}{10}R$$

$$R = \frac{4}{5}T \left(\frac{10}{3} \right) = \frac{8}{3}T \dots\dots [1]$$

↑

$$R + T \sin \theta = 49g$$

$$R + \frac{3}{5}T = 490$$

$$R = 490 - \frac{3}{5}T \dots\dots [2]$$

Substituting

$$\frac{8}{3}T = 490 - \frac{3}{5}T$$

$$\frac{49}{15}T = 490$$

$$T = 150 \text{ N}$$

$$R = \frac{8}{3}(150) = 400 \text{ N}$$

7

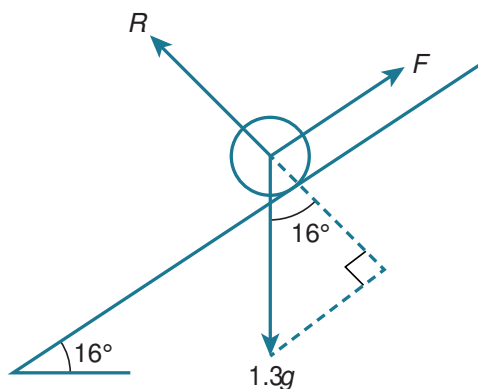

a ↙

$$R = 1.3g \cos 16^\circ = 12.4964\dots \text{ N}$$

$$F_{\max} = 0.45(12.496\dots) = 5.62338\dots \text{ N}$$

Component of weight down the slope

$$1.3g \sin 16^\circ = 3.583\dots < 5.62338$$

It remains stationary.

Friction will match the component of weight acting down the slope = 3.58 N.

b

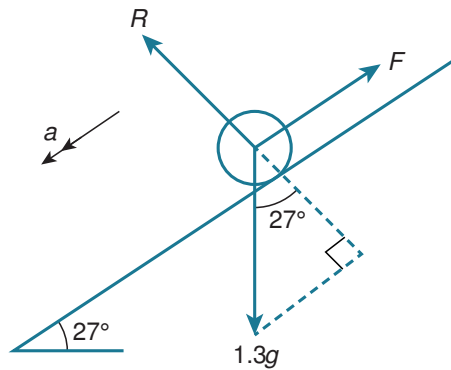

Component of weight acting down the slope

$$= 1.3g \sin 27^\circ = 13 \sin 27^\circ = 5.9018\dots$$

$$F_{\max} = 0.45(13 \cos 27^\circ) = 5.21\dots < 5.9018\dots$$

Weight is now enough to overcome the friction.

The book moves down the slope.

✓

$$13 \sin 27^\circ - 0.45(13 \cos 27^\circ) = 1.3a$$

$$a = 0.530 \text{ m s}^{-2}$$

8

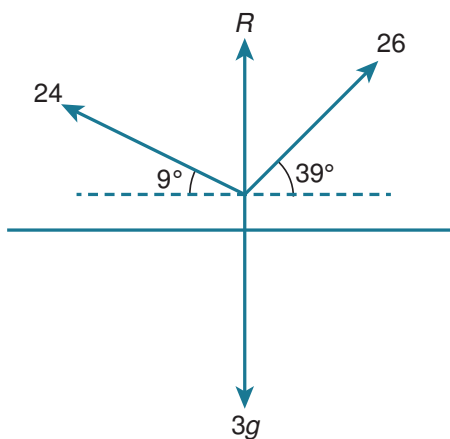

↑

$$R + 24 \sin 9^\circ + 26 \sin 39^\circ = 3g$$

$$R = 9.8832\dots \text{ N}$$

$$F_{\max} = 0.3R = 2.96497\dots \text{ N}$$

Difference between horizontal components produced by the boys

$$= 26 \cos 39^\circ - 24 \cos 9^\circ$$

$$= -3.4987\dots$$

Overall force to the left is greater than F_{\max} so the toy moves left.

←

$$24 \cos 9^\circ - 26 \cos 39^\circ - F = 3a$$

$$a = 0.178 \text{ m s}^{-2}$$

Note that you cannot decide on the direction of the friction until you know which boy is providing the greater horizontal force.

9 a

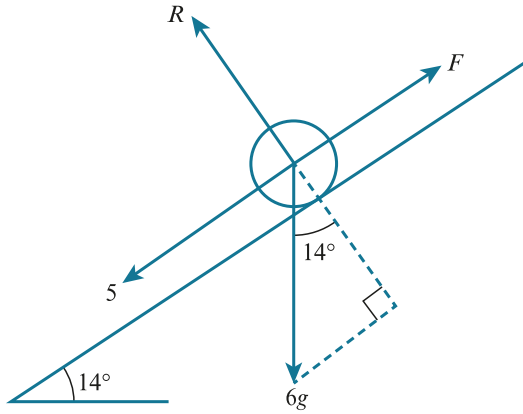

$$R = 6g \cos 14^\circ = 60 \cos 14^\circ = 58.2 \text{ N}$$

$$F_{\text{max}} = 0.4(60 \cos 14^\circ)$$

$$= 24 \cos 14^\circ = 23.3 \text{ N}$$

Forces down the slope

$$6g \sin 14^\circ + 5 = 19.5 \text{ N} < 23.3 \text{ N}$$

The forces cannot overcome friction.

$$F = 5 + 6g \sin 14^\circ$$

$$C = \sqrt{F^2 + R^2} = 61.4 \text{ N}$$

b If the 5 N force is removed then the object will not move.

This means that the 6g weight is exactly balanced by a contact force of 6g N vertically upwards.

So $C = 60 \text{ N}$ at $90^\circ - 14^\circ = 76^\circ$ to the slope.

10 a

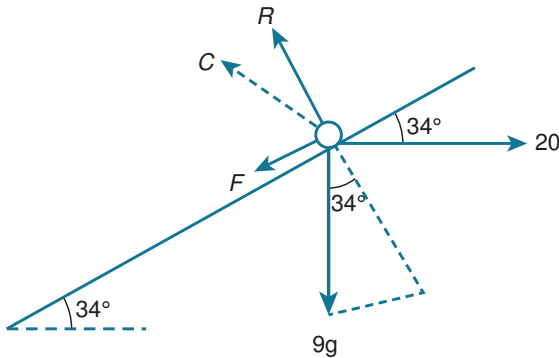

The contact force is balanced against the weight and holding force. If you find the resultant of the 20 N force and the weight, then the contact force must have the same magnitude but in the opposite direction.

$$C^2 = 90^2 + 20^2$$

$$C = \sqrt{8100 + 400} = 92.2 \text{ N}$$

b

$$\mu = \frac{F}{R}$$

$$= \frac{90 \sin 34 - 20 \cos 34}{90 \cos 34 + 20 \sin 34}$$

$$= \frac{33.7466...}{85.7972...}$$

$$= 0.393$$

11

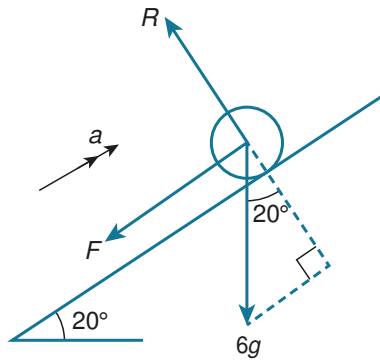

a ↙

$$R = 6g \cos 20^\circ = 60 \cos 20^\circ$$

$$F = 0.1(60 \cos 20^\circ) = 6 \cos 20^\circ$$

↗

Resultant force = ma

$$-6 \cos 20^\circ - 6g \sin 20^\circ = 6a$$

$$a = -\cos 20^\circ - 10 \sin 20^\circ$$

$$v = 0$$

$$u = 4$$

$$s = ?$$

$$v^2 = u^2 + 2as$$

$$s = \frac{0 - 4^2}{2(-\cos 20^\circ - 10 \sin 20^\circ)} = 1.83 \text{ m}$$

Time:

$$v = 0$$

$$u = 4$$

$$t = ?$$

$$v = u + at$$

$$t_1 = \frac{0 - 4}{-\cos 20^\circ - 10 \sin 20^\circ} = 0.91745\dots$$

(this will be used in the next part)

Sometimes you can save yourself time by reading ahead and spotting that you will need more information to answer a later part.

b

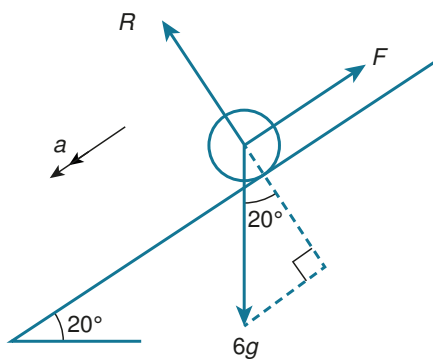

↙

Resultant force = ma

$$6g \sin 20^\circ - 6 \cos 20^\circ = 6a$$

$$a = 10 \sin 20^\circ - \cos 20^\circ$$

$$u = 0$$

$$t = ?$$

$$s = 5 + 1.8349\dots$$

$$s = ut + \frac{1}{2}at^2$$

$$t = 2.3475 \dots \text{ seconds}$$

$$\text{Total} = 2.3475 \dots + t_1 = 3.26 \text{ s}$$

12

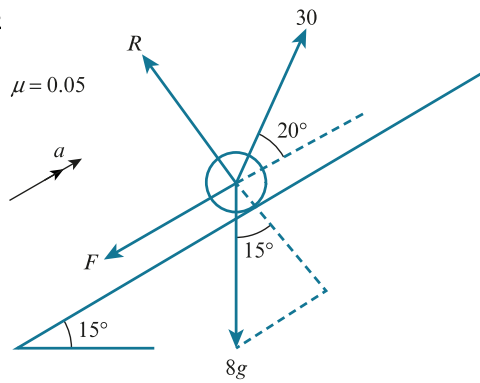

a ↖

$$R + 30 \sin 20^\circ = 8g \cos 15^\circ$$

$$R = 80 \cos 15^\circ - 30 \sin 20^\circ$$

$$F = 0.05(80 \cos 15^\circ - 30 \sin 20^\circ)$$

$$= 4 \cos 15^\circ - 1.5 \sin 20^\circ$$

↗

Resultant force = ma

$$30 \cos 20^\circ - (4 \cos 15^\circ - 1.5 \sin 20^\circ) - 8g \sin 15^\circ = 8a$$

$$a = 0.517 \text{ m s}^{-2}$$

b $v = ?$

$$u = 0$$

$$a = 0.517 \dots$$

$$s = 10$$

$$v^2 = u^2 + 2as$$

$$v = 3.22 \text{ m s}^{-1}$$

c

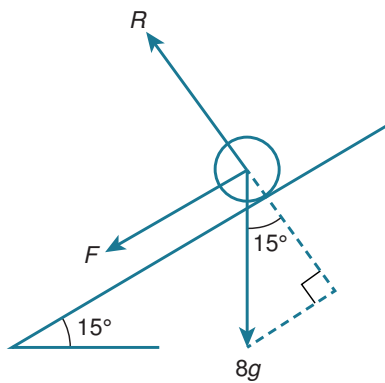

↖

$$R = 8g \cos 15^\circ = 80 \cos 15^\circ$$

$$F = 0.05(80 \cos 15^\circ) = 4 \cos 15^\circ$$

↗

Resultant force = ma

$$-4 \cos 15^\circ - 8g \sin 15^\circ = 8a$$

$$a = -0.5 \cos 15^\circ - 10 \sin 15^\circ$$

$$u = 3.22$$

$$v = 0$$

$$s = ?$$

$$v^2 = u^2 + 2as$$

$$s = \frac{0 - 3.22^2}{2a} = 1.6828 \dots$$

$$\text{Total} = 10 + 1.68 \dots$$

$$= 11.7 \text{ m}$$

d Time for the first part:

$$s = 10$$

$$u = 0$$

$$a = 0.517$$

$$t = ?$$

$$s = ut + \frac{1}{2}at^2$$

$$t = 6.2197 \text{ s}$$

Time for second part:

$$u = 3.22$$

$$v = 0$$

$$a = -0.5 \cos 15^\circ - 10 \sin 15^\circ$$

$$t = ?$$

$$v = u + at$$

$$t = \frac{0 - 3.22}{a} = 1.0485\dots$$

$$\text{total} = 7.27 \text{ s}$$

This question uses decimals very heavily. It is important that you try to record any decimal values to as many decimal places as you can, to avoid rounding errors later.

13 ↑

$$R = mg$$

$$F_{\max} = \mu mg$$

→

Resultant force = ma

$$-\mu mg = ma$$

$$a = -g\mu$$

At the change of surface:

$$u = u$$

$$a = -g\mu_1$$

$$v = ?$$

$$s = x$$

$$v^2 = u^2 + 2as$$

$$v = \sqrt{u^2 - 2g\mu_1 x}$$

Second part

Comes to rest when $v = 0$

$$“v^2 = u^2 + 2as”$$

$$0 = (u^2 - 2g\mu_1 x) - 2g\mu_2 y$$

$$2g\mu_2 y = u^2 - 2g\mu_1 x$$

$$\mu_2 = \frac{u^2 - 2g\mu_1 x}{2gy}$$

Notice how a general formula was found for friction on a level surface. This was then used with the two different friction coefficients, which means you do not need to re-work the original calculation.

Here we have used inverted commas around the formula because some of the letters used already appeared differently in the solution. This is a way of indicating which formula is being used.

14 a

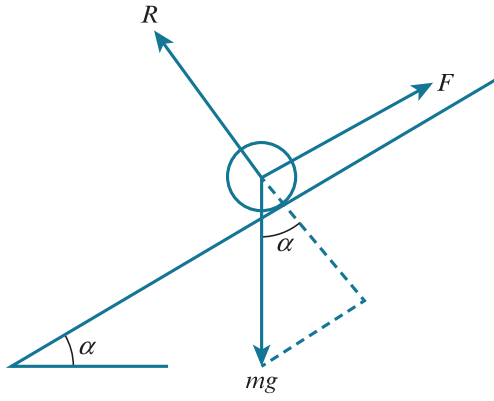

$$R = mg \cos \alpha$$

$$F = \mu_1 mg \cos \alpha$$



$$\mu_1 mg \cos \alpha = mg \sin \alpha$$

$$\mu_1 = \frac{mg \sin \alpha}{mg \cos \alpha} = \tan \alpha$$

b

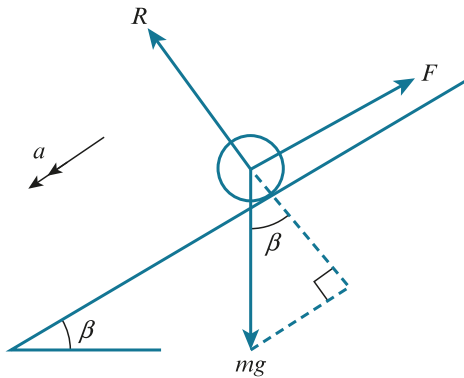

$$F = \mu_1 mg \cos \beta$$



Resultant force = ma

$$mg \sin \beta - F = ma$$

$$mg \sin \beta - \mu_1 mg \cos \beta = ma$$

$$g \sin \beta - (\tan \alpha) g \cos \beta = a$$

$$a = g \sin \beta - g \tan \alpha \cos \beta$$

$$u = 0$$

$$v = ?$$

$$a = g \sin \beta - g \tan \alpha \cos \beta$$

$$s = x$$

$$v^2 = u^2 + 2as$$

$$= 2g(\sin \beta - \tan \alpha \cos \beta)x$$

On level ground

$$a = -\mu_2 g$$

$$u^2 = 2gx(\sin \beta - \tan \alpha \cos \beta)$$

$$v = 0$$

$$s = y$$

$$“v^2 = u^2 + 2as”$$

$$0 = 2gx(\sin \beta - \tan \alpha \cos \beta) - 2\mu_2 gy$$

$$\mu_2 = \frac{2gx(\sin \beta - \tan \alpha \cos \beta)}{2gy}$$

$$= \frac{x(\sin \beta - \tan \alpha \cos \beta)}{y}$$

Here we have used inverted commas around the formula because some of the letters used already appeared

differently in the solution. This is a way of indicating which formula is being used.

15

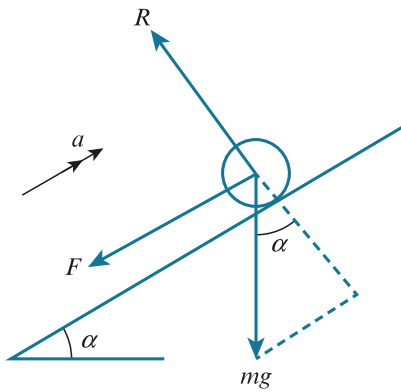

i $\sin \alpha = 0.28$

$$\cos \alpha = \sqrt{1 - 0.28^2} = 0.96$$

↙

$$R = mg \cos \alpha$$

$$F = \frac{1}{3}mg \cos \alpha$$

↗

Resultant force = ma

$$-\frac{1}{3}mg \cos \alpha - mg \sin \alpha = ma$$

$$\begin{aligned} a &= -\frac{1}{3}g \cos \alpha - g \sin \alpha \\ &= -\frac{1}{3}(10)(0.96) - 10(0.28) \\ &= -6 \text{ m s}^{-2} \end{aligned}$$

ii $u = 5.4$

$$a = -6$$

$$s = ?$$

$$v = 0$$

$$v^2 = u^2 + 2as$$

$$s = \frac{0 - 5.4^2}{-12}$$

$$= 2.43 \text{ m}$$

16 i

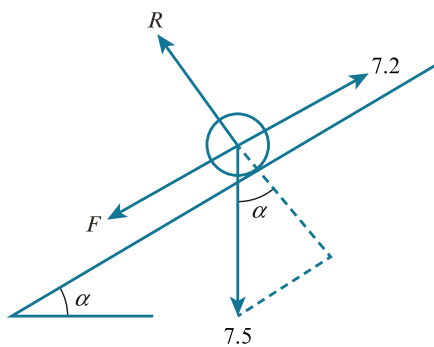

$$\tan \alpha = \frac{7}{24}$$

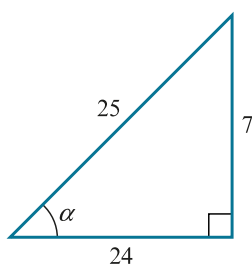

$$\sin \alpha = \frac{7}{25}$$

$$\cos \alpha = \frac{24}{25}$$

At rest

$$7.2 = F + 7.5 \sin \alpha$$

$$F = 7.2 - 7.5 \sin \alpha$$

$$F = 7.2 - 7.5 \left(\frac{7}{25} \right) = 5.1$$

$$5.1 \leq \mu R$$

↙

$$R = 7.5 \cos \alpha$$

$$= 7.5 \left(\frac{24}{25} \right) = 7.2$$

$$5.1 \leq 7.2\mu$$

$$\mu \geq \frac{5.1}{7.2} = \frac{17}{24}$$

ii Sliding downwards:

$$7.2 + 7.5 \sin \alpha > F_{\max}$$

$$7.2 + 7.5 \left(\frac{7}{25} \right) > \mu(7.5 \cos \alpha)$$

$$9.3 > 7.2\mu$$

$$\mu < \frac{9.3}{7.2} = \frac{31}{24}$$

17

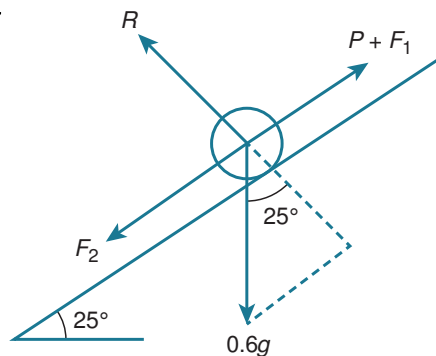

↙

$$R = 0.6g \cos 25^\circ$$

$$= 6 \cos 25^\circ$$

$$F_{\max} = 0.36(6 \cos 25^\circ)$$

$$= 2.16 \cos 25^\circ$$

About to slip up:

$$F_1 = 0$$

$$F_2 = F_{\max}$$

$$P = 2.16 \cos 25^\circ + 0.6g \sin 25^\circ = 4.49 \text{ N}$$

About to slip down:

$$F_1 = F_{\max}$$

$$F_2 = 0$$

↗

$$P + 2.16 \cos 25^\circ = 0.6g \sin 25^\circ$$

$$0.578 \leq P \leq 4.49$$

Chapter 5

Connected particles

EXERCISE 5A

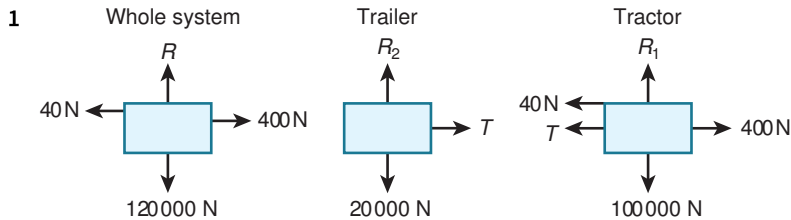

Newton's second law for the system

$$400 - 40 = (10\,000 + 2000) a$$

$$360 = 12\,000 a$$

$$a = 0.03 \text{ m s}^{-2}$$

Newton's second law for the tractor

$$400 - 40 - T = 10\,000 \times 0.03$$

$$360 - T = 300$$

$$T = 60 \text{ N}$$

Notice on the diagrams you show the weight, rather than the mass, as these are force diagrams.

You could have looked at Newton's second law for the trailer instead of the tractor. This would still give a tension of 60 N.

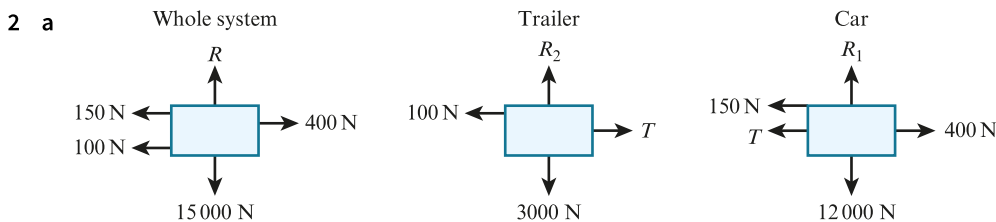

Newton's second law for the system

$$400 - 150 - 100 = (1200 + 300) a$$

$$150 = 1500 a$$

$$a = 0.1 \text{ m s}^{-2}$$

b Newton's second law for the car

$$400 - 150 - T = 1200 \times 0.1$$

$$250 - T = 120$$

$$T = 130 \text{ N}$$

Again, you could have looked at Newton's second law for the trailer instead of the car. This would still give a tension of 130 N and is a useful check to make sure you have made no mistakes.

3 a Weight of the box = 250 N so mass of the box = $250 \div 10 = 25 \text{ kg}$

Newton's second law for the box

$$20 = 25 a$$

$$a = 0.8 \text{ m s}^{-2}$$

b The box has been modelled as a particle so air resistance can be ignored.

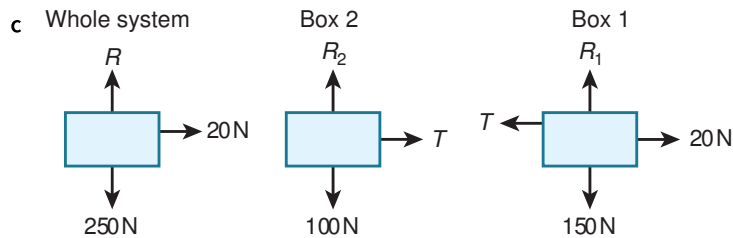

Newton's second law for the system

$$20 = (15 + 10) a$$

$$20 = 25a$$

$$a = 0.8 \text{ m s}^{-2}$$

Newton's second law for the box of weight 150 N

$$20 - T = 15 \times 0.8$$

$$20 - T = 12$$

$$T = 8 \text{ N}$$

Remember to change the weights of the boxes to masses when using Newton's second law.

Also note the acceleration for the system is the same as in part a because you have the same tension in the rope and the same overall mass.

d You have the same equations as in part c but the rope is now attached to the 100 N box instead.

The acceleration for the system will still be $a = 0.8 \text{ m s}^{-2}$ as you have the same tension in the rope and the same overall mass.

Newton's second law for the box of weight 100 N.

$$20 - T = 10 \times 0.8$$

$$20 - T = 8$$

$$T = 12 \text{ N}$$

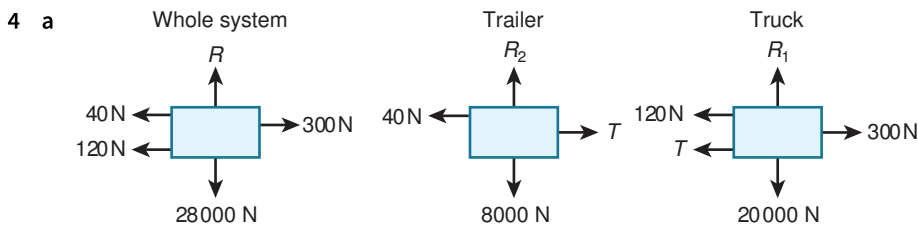

Newton's second law for the system

$$300 - 120 - 40 = (2000 + 800) a$$

$$140 = 2800 a$$

$$a = 0.05 \text{ m s}^{-2}$$

Newton's second law for the truck

$$300 - 120 - T = 2000 \times 0.05$$

$$180 - T = 100$$

$$T = 80 \text{ N}$$

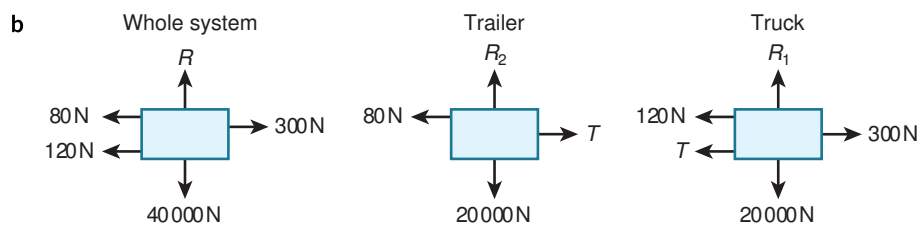

Newton's second law for the system

$$300 - 120 - 80 = (2000 + 800 + 1200) a$$

$$100 = 4000 a$$

$$a = 0.025 \text{ m s}^{-2}$$

Newton's second law for the truck

$$300 - 120 - T = 2000 \times 0.025$$

$$180 - T = 50$$

$$T = 130 \text{ N}$$

5 a

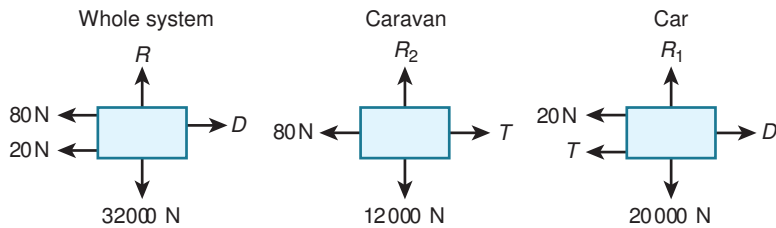

Newton's second law for the caravan

$$T - 80 = 1200a$$

However, $T \leq 680$, so $1200a + 80 \leq 680$

$$1200a \leq 600$$

$$a \leq 0.5 \text{ m s}^{-2}$$

Newton's second law for the system

$$D - 20 - 80 = (1200 + 2000)a$$

$$D - 100 = 3200a$$

But $a \leq 0.5 \text{ m s}^{-2}$

$$\text{So } D - 100 \leq 3200 \times 0.5$$

$$D \leq 1700$$

So the maximum possible driving force before the tow-bar breaks is 1700 N

b From part a, $a \leq 0.5 \text{ m s}^{-2}$

So the maximum possible acceleration is 0.5 m s^{-2}

6 a i

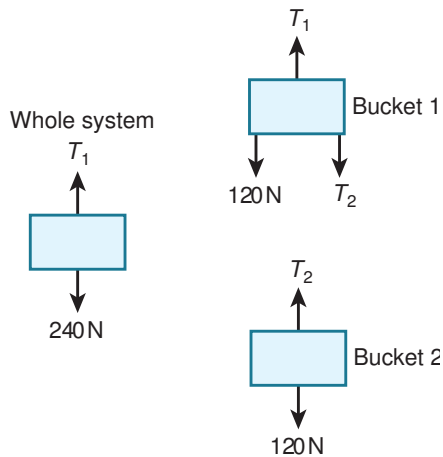

Newton's second law for the second bucket

$$T_2 - 120 = 0$$

$$T_2 = 120 \text{ N}$$

Newton's second law for the first bucket

$$T_1 - T_2 - 120 = 0$$

$$T_1 - 120 - 120 = 0$$

$$T_1 = 240 \text{ N}$$

ii Newton's second law for the second bucket

$$T_2 - 160 = 0$$

$$T_2 = 160 \text{ N}$$

Newton's second law for the first bucket

$$T_1 - T_2 - 80 = 0$$

$$T_1 - 160 - 80 = 0$$

$$T_1 = 240 \text{ N}$$

- b The masses of the rods are negligible, the second rod is vertical and the buckets of water can be modelled as particles.

7 Whole system

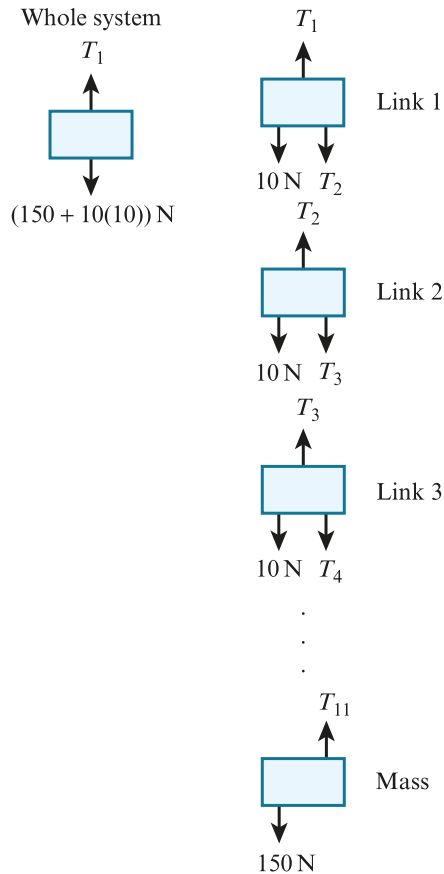

Newton's second law for the whole system

$$T_1 - 10 \times 10 - 150 = 0$$

$$T_1 = 250 \text{ N}$$

Newton's second law for the first link

$$T_1 - T_2 - 10 = 0$$

$$250 - T_2 - 10 = 0$$

$$T_2 = 240 \text{ N}$$

Newton's second law for the second link

$$T_2 - T_3 - 10 = 0$$

$$240 - T_3 - 10 = 0$$

$$T_3 = 230 \text{ N}$$

Newton's second law for the third link

$$T_3 - T_4 - 10 = 0$$

$$230 - T_4 - 10 = 0$$

$$T_4 = 220 \text{ N}$$

Newton's second law for the fourth link

$$T_4 - T_5 - 10 = 0$$

$$220 - T_5 - 10 = 0$$

$$T_5 = 210 \text{ N}$$

Newton's second law for the fifth link

$$T_5 - T_6 - 10 = 0$$

$$210 - T_6 - 10 = 0$$

$$T_6 = 200 \text{ N}$$

Newton's second law for the sixth link

$$T_6 - T_7 - 10 = 0$$

$$200 - T_7 - 10 = 0$$

$$T_7 = 190 \text{ N}$$

Newton's second law for the seventh link

$$T_7 - T_8 - 10 = 0$$

$$190 - T_8 - 10 = 0$$

$$T_8 = 180 \text{ N}$$

Newton's second law for the eighth link

$$T_8 - T_9 - 10 = 0$$

$$180 - T_9 - 10 = 0$$

$$T_9 = 170 \text{ N}$$

Newton's second law for the ninth link

$$T_9 - T_{10} - 10 = 0$$

$$170 - T_{10} - 10 = 0$$

$$T_{10} = 160 \text{ N}$$

Newton's second law for the tenth link

$$T_{10} - T_{11} - 10 = 0$$

$$160 - T_{11} - 10 = 0$$

$$T_{11} = 150 \text{ N}$$

You may have noticed a pattern with these tensions, which may save some time in your calculations.

8 Whole system

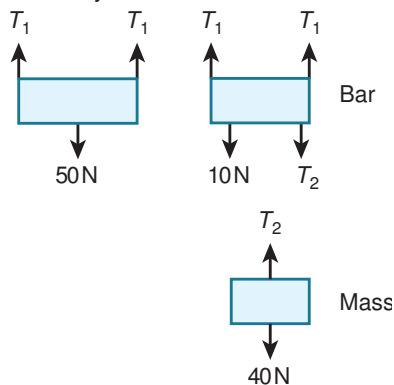

Newton's second law for the whole system

$$2T_1 - 50 = 0$$

$$T_1 = 25 \text{ N}$$

Newton's second law for the mass

$$T_2 - 40 = 0$$

$$T_2 = 40 \text{ N}$$

As the vertical rods are each connected to either end of the bar the tension in them will be the same.

9

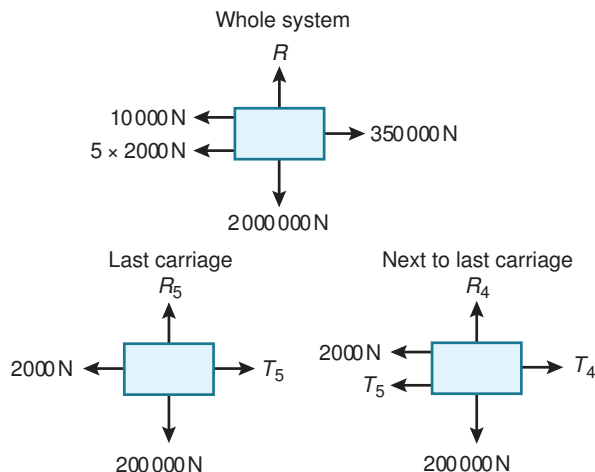

Newton's second law for the whole system

$$350\,000 - 10\,000 - 5 \times 2000 = (100\,000 + 5 \times 20\,000) a$$

$$330\,000 = 200\,000 a$$

$$a = 1.65 \text{ m s}^{-2}$$

Newton's second law for the last carriage

$$T_5 - 2000 = 20\,000 \times 1.65$$

$$T_5 - 2000 = 33\,000$$

$$T_5 = 35\,000 \text{ N}$$

Newton's second law for next to the last carriage

$$T_4 - T_5 - 2000 = 20\,000 \times 1.65$$

$$T_4 - 35\,000 - 2000 = 33\,000$$

$$T_4 = 70\,000 \text{ N}$$

10

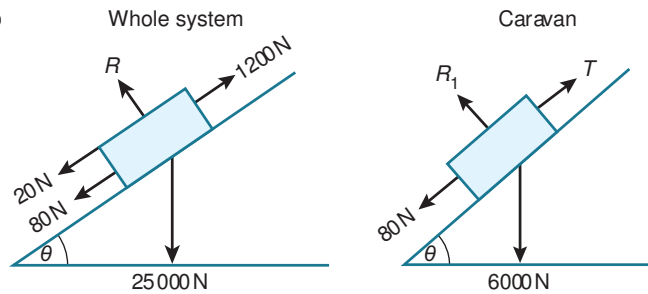

Newton's second law for the system

$$1200 - 20 - 80 - (6000 + 19\,000) \sin \theta = (600 + 1900) a$$

$$1100 - 25\,000 \times \frac{1}{20} = 2500 a$$

$$-150 = 2500 a$$

$$a = -0.06 \text{ m s}^{-2}$$

Newton's second law for the caravan

$$T - 80 - 6000 \sin \theta = 600 \times (-0.06)$$

$$T - 80 - 6000 \times \frac{1}{20} = -36$$

$$T - 80 - 300 = -36$$

$T = 344$ so the force in the tow-bar is 344 N and it is a tension force.

11

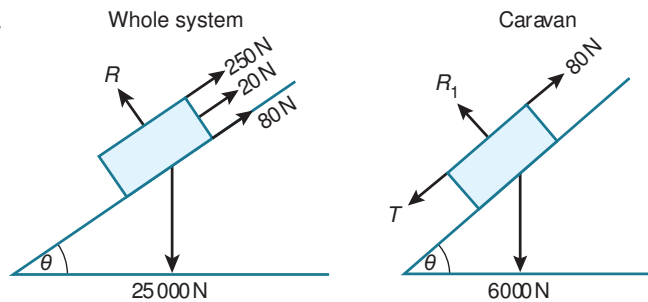

Newton's second law for the system

$$(6000 + 19\,000) \sin \theta - 250 - 20 - 80 = (600 + 1900) a$$

$$25\,000 \times \frac{1}{20} - 350 = 2500 a$$

$$900 = 2500 a$$

$$a = 0.36 \text{ m s}^{-2}$$

Newton's second law for the caravan

$$6000 \sin \theta + T - 80 = 600 \times 0.36$$

$$6000 \times \frac{1}{20} + T - 80 = 216$$

$$T + 220 = 216$$

$T = -4$ so the force in the tow-bar is 4 N and it is a thrust force.

12

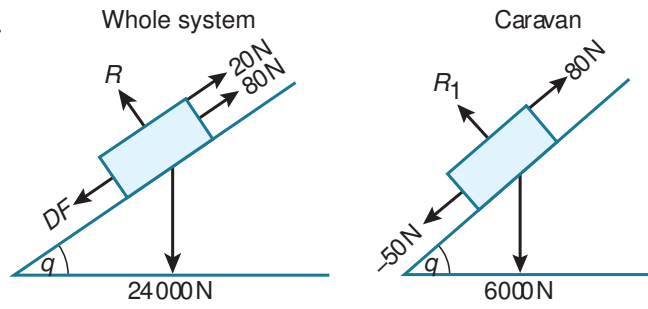

Newton's second law for the caravan

$$6000 \sin \theta - 50 - 80 = 600a$$

$$6000 \times 0.05 - 130 = 600a$$

$$170 = 600a$$

$$a = 0.28\dot{3} \text{ m s}^{-2}$$

Newton's second law for the system

$$24\,000 \sin \theta + DF - 80 - 20 = 2400 \times 0.28\dot{3}$$

$$24\,000 \times 0.05 + DF - 100 = 680$$

$$DF + 1100 = 680$$

$DF = -420$ so the force from the car's engine is -420 N as required

EXERCISE 5B

1 a

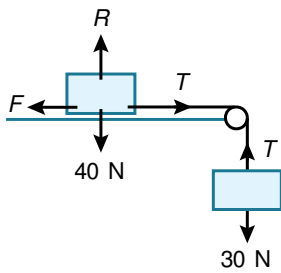

Newton's second law for the 3 kg mass

$$30 - T = 0$$

$$T = 30 \text{ N}$$

Newton's second law for the 4 kg mass

$$T - F = 0$$

$$30 - F = 0$$

$$F = 30 \text{ N}$$

b

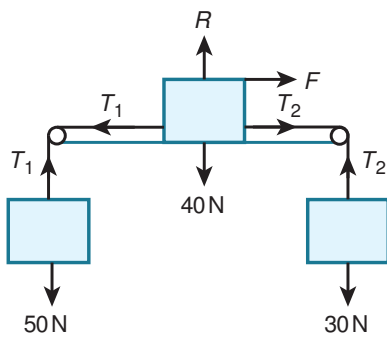

Newton's second law for the 5 kg mass

$$50 - T_1 = 0$$

$$T_1 = 50 \text{ N}$$

Newton's second law for the 3 kg mass

$$T_2 - 30 = 0$$

$$30 - T_2 = 0$$

$$T_2 = 30 \text{ N}$$

Newton's second law for the 4 kg mass

$$T_1 - T_2 - F = 0$$

$$50 - 30 - F = 0$$

$$F = 20 \text{ N}$$

c

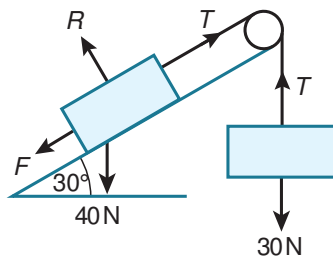

Newton's second law for the 3 kg mass

$$30 - T = 0$$

$$T = 30 \text{ N}$$

Newton's second law for the 4 kg mass

$$T - F - 40 \sin 30 = 0$$

$$30 - F - 20 = 0$$

$$F = 10 \text{ N}$$

d

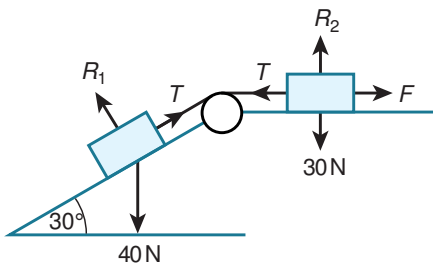

Newton's second law for the 4 kg mass

$$40 \sin 30 - T = 0$$

$$20 - T = 0$$

$$T = 20 \text{ N}$$

Newton's second law for the 3 kg mass

$$T - F = 0$$

$$20 - F = 0, F = 20 \text{ N}$$

2 a Newton's second law for the full bucket (vertically downwards)

$$90 - T = 9a \dots\dots\dots [1]$$

Apply Newton's second law in the direction of motion for each object. In this question, the full bucket is moving downwards as it is heavier than the empty bucket, which moves upwards. You should state the direction you are taking as positive in each case.

Newton's second law for the empty bucket (vertically upwards)

$$T - 30 = 3a \dots\dots\dots [2]$$

[1] + [2] gives

$$90 - 30 = 12a$$

$$60 = 12a$$

$$a = 5 \text{ m s}^{-2}$$

$$a = 5, u = 0, s = 22.5$$

Using $s = ut + \frac{1}{2}at^2$

$$22.5 = \frac{1}{2}(5)t^2$$

$$t^2 = 9$$

$$t = 3 \text{ s}$$

b The rope is modelled as a light inextensible string and the buckets as particles.

3 Whole system 2 kg box 0.4 kg box 0.6 kg box

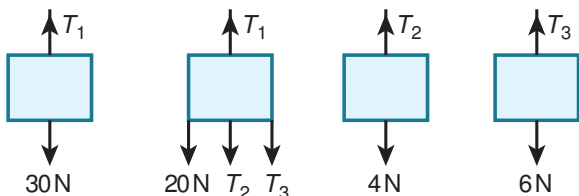

Newton's second law for the whole system

$$T_1 - 20 - 4 - 6 = 0$$

$$T_1 = 30 \text{ N}$$

Newton's second law for the 0.4 kg mass

$$T_2 - 4 = 0$$

$$T_2 = 4 \text{ N}$$

Newton's second law for the 0.6 kg mass

$$T_3 - 6 = 0$$

$$T_3 = 6 \text{ N}$$

4 a

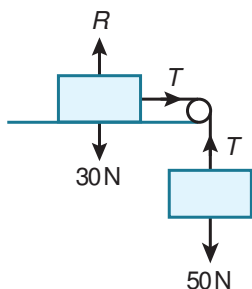

Newton's second law for the 5 kg mass (vertically downwards)

$$50 - T = 5a \dots\dots\dots [1]$$

Newton's second law for the 3 kg mass (horizontally to the right)

$$T = 3a \dots\dots\dots [2]$$

[1] + [2] gives

$$50 = 8a$$

$$a = 6.25 \text{ m s}^{-2}$$

The portion of the string from the pulley to the 5 kg mass is $2 - 1.5 = 0.5 \text{ m}$

The distance the 5 kg mass has to fall is $0.7 - 0.5 = 0.2 \text{ m}$

$$a = 6.25, u = 0, s = 0.2$$

Using $s = ut + \frac{1}{2}at^2$

$$0.2 = \frac{1}{2}(6.25)t^2$$

$$t^2 = 0.064$$

$$t = 0.2529\dots$$

$$t = 0.253 \text{ s}$$

b $a = 6.25, u = 0, s = 0.2$

Using $v^2 = u^2 + 2as$

$$v^2 = 0^2 + 2(6.25)(0.2)$$

$$v^2 = 2.5$$

$$v = 1.581\dots = 1.58 \text{ m s}^{-1}$$

While the 5 kg mass is falling, the speed of the 3 kg mass is the same as the 5 kg mass because they are connected by the string.

c The distance the 3 kg mass has to move to reach the pulley is $1.5 - 0.2 = 1.3 \text{ m}$

$$a = 0, u = 1.581\dots, s = 1.3$$

Using $s = ut + \frac{1}{2}at^2$

$$1.3 = 1.581\dots t$$

$$t = 0.8221\dots$$

The total time for the 3 kg mass to reach the pulley is $0.2529\dots + 0.8221\dots = 1.075\dots = 1.08 \text{ s}$

The acceleration of the 3 kg mass after the 5 kg mass reaches the floor is 0 m s^{-2} as the string has become slack and there is no horizontal force (the direction of motion) acting on the 3 kg mass.

5 a Newton's second law for the 1 kg mass (vertically downwards)

$$10 - T = 1a \dots\dots\dots [1]$$

Newton's second law for the 0.6 kg mass (vertically upwards)

$$T - 6 = 0.6a \dots\dots\dots [2]$$

[1] + [2] gives

$$4 = 1.6a$$

$$a = 2.5 \text{ m s}^{-2}$$

$$a = 2.5, u = 0, s = 1.8$$

$$\text{Using } s = ut + \frac{1}{2}at^2$$

$$1.8 = \frac{1}{2}(2.5)t^2$$

$$t^2 = 1.44$$

$$t = 1.2 \text{ s}$$

b Find the velocity of X when the string breaks.

$$a = 2.5, u = 0, s = 1.8$$

$$\text{Using } v^2 = u^2 + 2as$$

$$v^2 = 0^2 + 2(2.5)(1.8)$$

$$v^2 = 9$$

$$v = 3 \text{ m s}^{-1}$$

After the string breaks, the acceleration of X will be 10 m s^{-2} downwards.

The distance X has to move to reach the ground is $3 - (0.4 + 1.8) = 0.8 \text{ m}$

$$a = 10, u = 3, s = 0.8$$

$$\text{Using } s = ut + \frac{1}{2}at^2$$

$$0.8 = 3t + \frac{1}{2}(10)t^2$$

$$5t^2 + 3t - 0.8 = 0$$

$$\text{Using } \frac{-b \pm \sqrt{b^2 - 4ac}}{2a}$$

$$t = \frac{-3 \pm \sqrt{3^2 - 4(5)(-0.8)}}{2(5)}$$

$$t = \frac{-3 \pm \sqrt{25}}{10}$$

$$t = 0.2, -0.8$$

As t must be positive, $t = 0.2 \text{ s}$

So the total time from when the system is released is $1.2 + 0.2 = 1.4 \text{ s}$

6 a

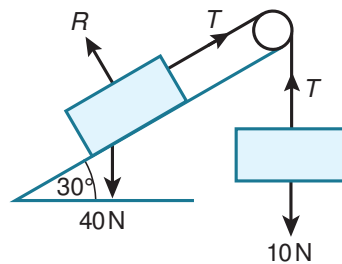

Newton's second law for the 4 kg mass (perpendicular to the plane)

$$R - 40 \cos 30 = 0$$

$$\text{so } R = 40 \cos 30$$

$$F = \mu R = 0.2 \times 40 \cos 30 = 8 \cos 30$$

Newton's second law for the 1 kg mass (vertically upwards)

$$T - 10 = 1 a \dots\dots\dots [1]$$

Newton's second law for the 4 kg mass (parallel to and down plane)

$$40 \sin 30 - T - F = 4a$$

$$20 - T - 8 \cos 30 = 4a \dots\dots\dots [2]$$

[1] + [2] gives

$$10 - 8 \cos 30 = 5a$$

$$a = 0.614 \dots \text{ m s}^{-2}$$

From [1] $T = 10 + a = 10 + 0.614\dots = 10.614\dots = 10.6\text{ N}$

b $a = 0.614\dots, u = 0, t = 1.2$

Using $s = ut + \frac{1}{2}at^2$

$$s = \frac{1}{2}(0.614\dots)(1.2)^2$$

$$s = 0.4423\dots$$

$$s = 0.44\text{ m}$$

So a lower bound for the string is 0.44 m

7 Newton's second law for the 0.5 kg and 0.2 kg masses (vertically downwards)

$$5 + 2 - T_1 = (0.5 + 0.2) a \dots\dots\dots [1]$$

Newton's second law for the 0.3 kg mass (vertically upwards)

$$T_1 - 3 = 0.3a \dots\dots\dots [2]$$

[1] + [2] gives

$$4 = a$$

$$a = 4\text{ m s}^{-2}$$

$$T_1 = 3 + 0.3 \times 4 = 4.2\text{ N}$$

Newton's second law for the 0.2 kg mass (vertically downwards)

$$2 - T_2 = 0.2a$$

$$\text{So } 2 - T_2 = 0.2 \times 4$$

$$2 - T_2 = 0.8$$

$$T_2 = 1.2\text{ N}$$

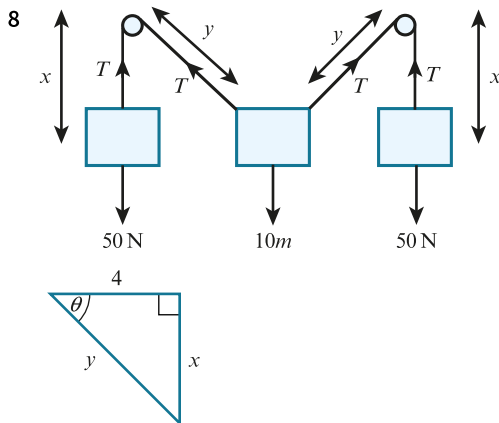

First find the angle between the horizontal and the rope.

The total length of the rope is 16 m, so

$$2x + 2y = 16$$

$$x + y = 8$$

$$x = 8 - y$$

Using Pythagoras

$$(8 - y)^2 + 4^2 = y^2$$

$$64 - 16y + y^2 + 16 = y^2$$

$$80 - 16y = 0$$

$$y = 5$$

$$x = 8 - y = 8 - 5 = 3$$

$$\sin \theta = \frac{3}{5} = 0.6$$

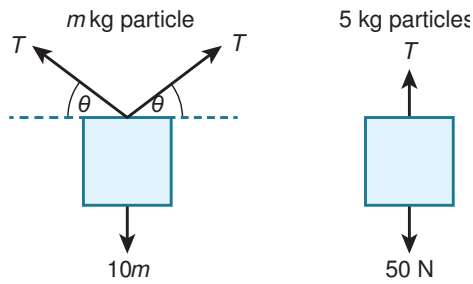

Newton's second law for either of the 5 kg particles (vertically upwards)

$$T - 50 = 0$$

$$T = 50 \text{ N}$$

Newton's second law for the m kg particle (vertically upwards)

$$T \sin \theta + T \sin \theta - 10m = 0$$

$$2 \times 50 \times 0.6 = 10m$$

$$10m = 60$$

$$m = 6$$

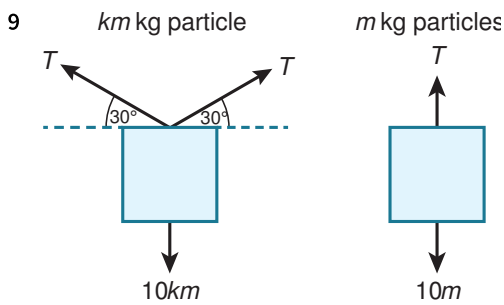

Newton's second law for either of the m kg particles (vertically upwards)

$$T - 10m = 0$$

$$T = 10m$$

Newton's second law for the km kg particle (vertically upwards)

$$T \sin 30 + T \sin 30 - 10km = 0$$

$$2 \times 10m \times 0.5 = 10km$$

$$10m = 10km$$

$$k = 1$$

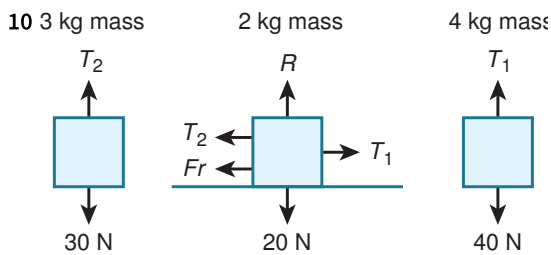

a Newton's second law for the 2 kg mass (vertically upwards)

$$R - 20 = 0$$

$$R = 20 \text{ N}$$

$$F = \mu R = 0.05 \times 20 = 1 \text{ N} \dots\dots [1]$$

Newton's second law for the 4 kg mass (vertically downwards)

$$40 - T_1 = 4a \dots\dots\dots [2]$$

Newton's second law for the 3 kg mass (vertically upwards)

$$T_2 - 30 = 3a \dots\dots\dots [3]$$

Newton's second law for the 2 kg mass (horizontally towards the 4 kg mass)

$$T_1 - T_2 - F = 2a$$

$$T_1 - T_2 - 1 = 2a \dots\dots\dots [4]$$

[2] + [3] + [4] gives

$$40 - 30 - 1 = 9a$$

$$9 = 9a$$

$$a = 1 \text{ m s}^{-2}$$

b From [2]

$$40 - T_1 = 4a$$

$$40 - T_1 = 4 \times 1 = 4$$

$$T_1 = 36 \text{ N}$$

From [3]

$$T_2 - 30 = 3a$$

$$T_2 - 30 = 3 \times 1 = 3$$

$$T_2 = 33 \text{ N}$$

11

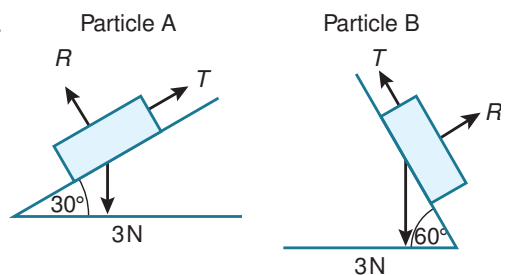

a Newton's second law for particle A (parallel to and up the plane)

$$T - 3 \sin 30 = 0.3a \dots\dots\dots [1]$$

Newton's second law for particle B (parallel to and down the plane)

$$3 \sin 60 - T = 0.3a \dots\dots\dots [2]$$

[1] + [2] gives

$$3 \sin 60 - 3 \sin 30 = 0.6a$$

$$3 \left(\frac{\sqrt{3}}{2} \right) - 3 \left(\frac{1}{2} \right) = \frac{3}{5}a$$

$$\frac{5\sqrt{3}}{2} - \frac{5}{2} = a$$

But from [1]

$$T = 0.3a + 3 \sin 30$$

$$T = \frac{3}{10} \left(\frac{5\sqrt{3}}{2} - \frac{5}{2} \right) + \frac{3}{2}$$

$$T = \frac{3\sqrt{3}}{4} - \frac{3}{4} + \frac{3}{2}$$

$$= \frac{3\sqrt{3}}{4} + \frac{3}{4}$$

$$= \frac{3(1 + \sqrt{3})}{4} \text{ N}$$

b Newton's second law for particle A (perpendicular to the plane)

$$R - 3 \cos 30 = 0$$

Newton's second law for particle A (horizontally to the right)

$$\text{Resultant horizontal force} = T \cos 30 - R \sin 30$$

$$R = 3 \cos 30 \text{ and (from part a) } T = \frac{3(1 + \sqrt{3})}{4}$$

$$\text{So resultant horizontal force} = \frac{3(1 + \sqrt{3})}{4} \left(\frac{\sqrt{3}}{2} \right) - 3 \left(\frac{\sqrt{3}}{2} \right) \left(\frac{1}{2} \right)$$

$$= \frac{3\sqrt{3}}{8} + \frac{9}{8} - \frac{3\sqrt{3}}{4} = \frac{9}{8} - \frac{3\sqrt{3}}{8} = 0.47548 \dots = 0.475 \text{ N}$$

Newton's second law for particle B (perpendicular to the plane)

$$R - 3 \cos 60 = 0$$

Newton's second law for particle B (horizontally to the right)

Resultant horizontal force = $R \sin 60 - T \cos 60$

$R = 3 \cos 60$ and from part a $T = \frac{3(1 + \sqrt{3})}{4}$

So resultant horizontal force = $3 \left(\frac{1}{2}\right) \left(\frac{\sqrt{3}}{2}\right) - \frac{3(1 + \sqrt{3})}{4} \left(\frac{1}{2}\right)$
 $= \frac{3\sqrt{3}}{4} - \frac{3}{8} - \frac{3\sqrt{3}}{8} = \frac{3\sqrt{3}}{8} - \frac{3}{8} = 0.2745 \dots = 0.275 \text{ N}$

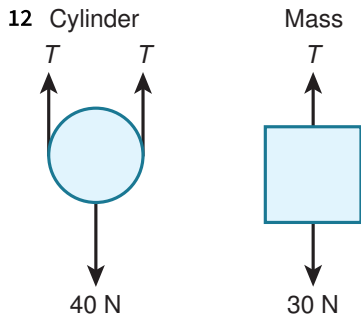

a There are two lengths of string at the cylinder, so the distance moved by the cylinder in a given time is half the distance moved by the box, hence the speed and the magnitude of the acceleration are also half those of the box.

b Newton's second law for the mass (vertically downwards)

$30 - T = 3a$ [1]

Newton's second law for the cylinder (vertically upwards)

$T + T - 40 = 4 \left(\frac{a}{2}\right)$

So $2T - 40 = 2a$ [2]

From [1] $T = 30 - 3a$

Substitute T into [2]:

$2(30 - 3a) - 40 = 2a$

$60 - 6a - 40 = 2a$

$8a = 20$

$a = 2.5 \text{ m s}^{-2}$

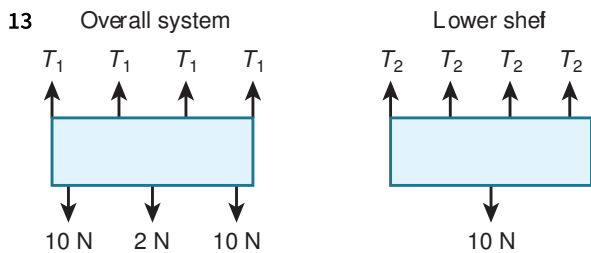

a The strings are light, inextensible and hang vertically.

b Newton's second law for the whole system (vertically upwards)

$4T_1 - 10 - 2 - 10 = 0$

$4T_1 = 22$

$T_1 = 5.5 \text{ N}$

c Newton's second law for the lower shelf (vertically upwards)

$4T_2 - 10 = 0$

$T_2 = 2.5 \text{ N}$

d Newton's second law for the whole system (vertically upwards)

$4T_1 - 10 - 2 - 10 = 0$

$4T_1 = 22$

$T_1 = 5.5 \text{ N}$ so the upper tension stays the same

Newton's second law for the lower shelf (vertically upwards)

$$4T_2 - 10 - 2 = 0$$

$$4T_2 = 12$$

$T_2 = 3 \text{ N}$ so the lower tension increases.

EXERCISE 5C

1 Whole system

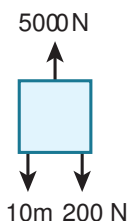

Lift

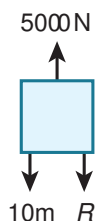

Crate



a For the crate

$$R - 200 = 20 \times 0.3$$

$$R - 200 = 6$$

$$R = 206 \text{ N}$$

b For the system

$$5000 - 200 - 10m = (20 + m) \times 0.3$$

$$4800 - 10m = 6 + 0.3m$$

$$10.3m = 4794$$

$$m = 465.43 \dots = 465 \text{ kg}$$

You could find m by considering Newton's second law for only the lift, rather than the whole system. However, this method uses your calculated value of R . If you have made a mistake when finding R , it will make the next part of your answer incorrect too. If possible, use values given in the question rather than relying on values you find.

2 Whole system

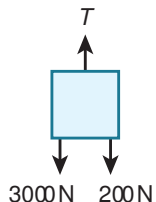

Lift

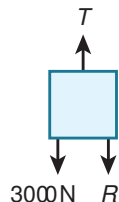

Crate



a For the system vertically upwards

$$T - 200 - 3000 = (20 + 300) \times 0.3$$

$$T - 3200 = 96$$

$$T = 3296 = 3300 \text{ N}$$

Use Newton's second law in the direction of motion (upwards).

b For the system vertically upwards

$$T - 200 - 3000 = 0$$

$$T - 3200 = 0$$

$$T = 3200 \text{ N}$$

You should use Newton's second law in the direction of motion, however the question does not state the direction of motion. In this question, it does not matter which direction you take as positive, but you should still state the direction you have chosen.

c For the system vertically downwards

$$200 + 3000 - T = (20 + 300) \times 0.3$$

$$3200 - T = 96$$

$$T = 3104 = 3100 \text{ N}$$

Use Newton's second law in the direction of motion (upwards).

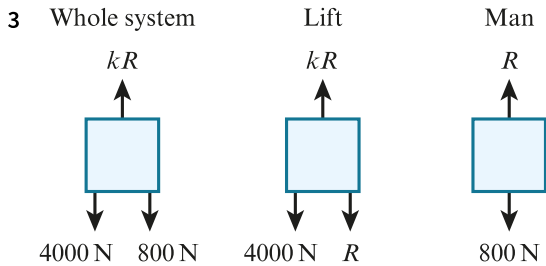

For the man vertically downwards

$$800 - R = 80 \times 8$$

$$800 - R = 640$$

$$R = 160 \text{ N}$$

You can apply Newton's second law to any of the three situations in the diagram, however as the man's equation contains only one unknown this is a good place to start as you can find R immediately.

For the system vertically downwards

$$800 + 4000 - kR = (80 + 400) \times 8$$

$$4800 - kR = 3840$$

$$kR = 960 \text{ N}$$

$$160k = 960$$

so $k = 6$

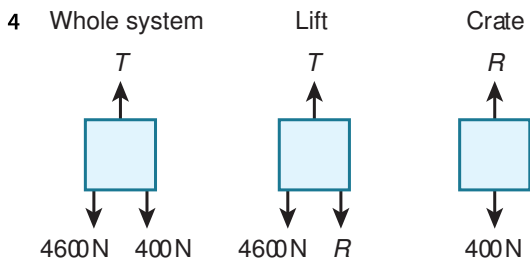

a For the system vertically upwards

$$T - 400 - 4600 = (40 + 460) \times 0.4$$

$$T - 5000 = 200$$

$$T = 5200 \text{ N}$$

b For the crate vertically upwards

$$R - 400 = 40 \times 0.4$$

$$R - 400 = 16$$

$$R = 416 \text{ N}$$

You could use Newton's second law on either the lift or the crate to find R . However, the equation for the lift includes your calculated value from part a so it is better to avoid this. As in Question 1, if possible use values given in the question rather than relying on values you calculate.

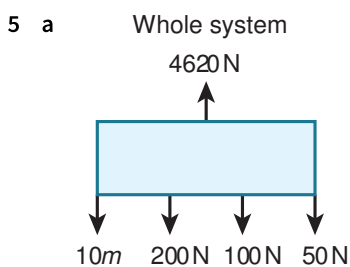

Let the mass of the lift be m .

For the system vertically upwards

$$4620 - 200 - 100 - 50 - 10m = (20 + 10 + 5 + m) \times 0.5$$

$$4270 - 10m = 17.5 + 0.5m$$

$$10.5m = 4252.5$$

$$m = 405 \text{ kg}$$

Apply Newton's second law to the whole system first, so the reaction forces between the items in contact do not appear in the equation.

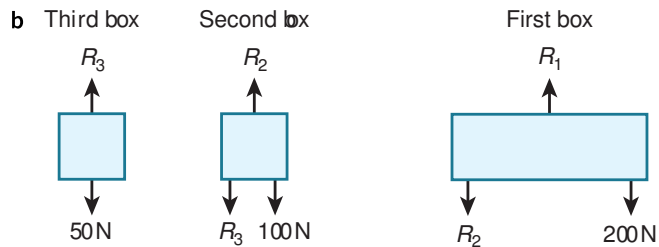

For the third box vertically upwards

$$R_3 - 50 = 5 \times 0.5$$

$$R_3 - 50 = 2.5$$

$$R_3 = 52.5 \text{ N}$$

For the second box vertically upwards

$$R_2 - R_3 - 100 = 10 \times 0.5$$

$$R_2 - 52.5 - 100 = 5$$

$$R_2 = 157.5$$

For the first box vertically upwards

$$R_1 - R_2 - 200 = 20 \times 0.5$$

$$R_1 - 157.5 - 200 = 10$$

$$R_1 = 367.5 = 368 \text{ N}$$

The normal reaction force (R_3) on the third (top) box acts upwards as it is the force from the surface it is resting on, which is the second (middle) box.

The second (middle) box experiences a normal reaction (R_2) acting upwards from the surface it is resting on, the first (bottom) box. It also experiences the normal reaction (R_3) downwards from the third (top) box.

The first (bottom) box experiences a normal reaction (R_1) acting upwards from the surface it is resting on, the floor of the lift. It also experiences the normal reaction (R_2) downwards from the second (middle) box.

c From part b: $R_2 = 157.5 = 158 \text{ N}$

d From part b: $R_3 = 52.5 \text{ N}$

6 a For the lift vertically upwards

$$2500 - 2000 = 200a$$

$$500 = 200a$$

$$a = 2.5 \text{ m s}^{-2}$$

b For the system vertically upwards

$$2500 - 2000 - 400 = (200 + 40) \times a$$

$$100 = 240a$$

$$a = 0.41\dot{6} \text{ m s}^{-2}$$

As the lift now carries a load, the maximum acceleration will now be lower than that found in part a so you need to recalculate it.

For the load vertically upwards

$$R - 400 = 40 \times 0.41\dot{6}$$

$$R - 400 = 16.\dot{6}$$

$$R = 416.\dot{6} = 417 \text{ N}$$

- 7 a For the system vertically upwards

$$T - 10M - 10m = (M + m) \times a$$

$$T = 10(M + m) + (M + m)a$$

$$T = (M + m)(10 + a) \text{ N}$$

- b For the crate vertically upwards

$$R - 10m = ma$$

$$R = 10m + ma$$

$$R = m(10 + a) \text{ N}$$

- 8 a For the top box vertically upwards

$$R_1 - 30 = 3 \times 0.7$$

$$R_1 - 30 = 2.1$$

$$R_1 = 32.1 \text{ N}$$

As in Question 5, the box in contact with the floor of the lift will experience two normal contact forces, one from being in contact with the floor of the lift and the other from being in contact with the top box. As there will be two unknowns for Newton's second law when applied to the bottom box, logically you should apply Newton's second law to the top box instead.

- b For the top box vertically upwards

$$R_1 - 50 = 5 \times 0.7$$

$$R_1 - 50 = 3.5$$

$$R_1 = 53.5 \text{ N so the contact force between the two boxes increases.}$$

- 9 a i For the system vertically upwards

$$12\,000 - 5000 - 10m = (500 + m) \times 0.75$$

$$7\,000 - 10m = 375 + 0.75m$$

$$10.75m = 6625$$

$$m = 616.279 \dots = 616 \text{ kg}$$

- ii For the system vertically downwards

$$5000 + 10m - 12\,000 = (500 + m) \times 0.75$$

$$10m - 7\,000 = 375 + 0.75m$$

$$9.25m = 7375$$

$$m = 797.297 \dots = 797 \text{ kg}$$

When the lift is travelling upwards, the weight of the passengers is acting against the direction of motion, so for a given acceleration the weight will be lower than when travelling downwards.

In this case, the weight of the passengers is acting in the same direction as the motion, so for a given acceleration the weight will be higher.

- b For the maximum number of passengers allowed to travel in the lift, use the maximum mass of the passengers when travelling upwards, as this gives the lowest allowable mass.

Using $m = 616.279 \dots$ and an average mass of a person to be 75 kg, maximum number of passengers allowed in the lift is $616.279 \dots \div 75 = 8.21 \dots = 8$ people.

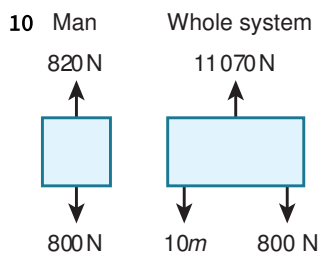

As the scales suggest the weight of the man is 820 N this is equivalent to the normal reaction force on the man.

For the man vertically upwards

$$820 - 800 = 80a$$

$$20 = 80a$$

$$a = 0.25 \text{ m s}^{-2}$$

For the system vertically upwards

Let the mass of the lift be m .

$$11\,070 - 10m - 800 = (80 + m) \times 0.25$$

$$10\,270 - 10m = 20 + 0.25m$$

$$10.25m = 10\,250$$

$m = 1000 \text{ kg}$ so the weight is $10m = 10\,000 \text{ N}$

11 a Newton's second law for mass B (vertically downwards)

$$30 - T = 3a \dots\dots\dots [1]$$

Newton's second law for the mass A (vertically upwards)

$$T - 20 = 2a \dots\dots\dots [2]$$

[1] + [2] gives

$$30 - 20 = 5a$$

$$10 = 5a$$

$$a = 2 \text{ m s}^{-2}$$

So mass A has acceleration 2 m s^{-2} upwards and mass B has acceleration 2 m s^{-2} downwards

b Whole system

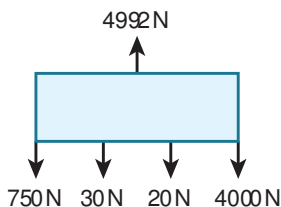

For the system vertically upwards

$$4992 - 4000 - 750 - 30 - 20 = (400 + 75 + 3 + 2) a$$

$$192 = 480a$$

$$a = 0.4 \text{ m s}^{-2} \text{ upwards}$$

c For mass A from part **a** acceleration 2 m s^{-2} upwards and from part **b** acceleration 0.4 m s^{-2} upwards giving an overall acceleration of $2 + 0.4 = 2.4 \text{ m s}^{-2}$ upwards.

For mass B from part **a** acceleration 2 m s^{-2} downwards and from **b** acceleration 0.4 m s^{-2} upwards giving an overall acceleration of $2 - 0.4 = 1.6 \text{ m s}^{-2}$ downwards.

The accelerations of A and B you found in part **a** are the accelerations relative to the lift. These are the accelerations you would observe if you were inside the lift.

The accelerations of A and B you found in part **c** are the accelerations you would observe if you were stationary outside the lift. They are the accelerations relative to the earth.

You may wish to read more about relative motion.

END-OF-CHAPTER REVIEW EXERCISE 5

1 a

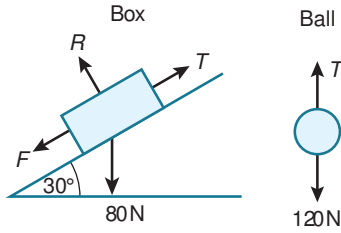

Remember as the box is moving up the slope, the frictional force acts down the slope. Apply Newton's second law separately to the box and ball to find the acceleration of the system, then use equations of constant acceleration to find the required time.

Newton's second law for the 8 kg box (perpendicular to the plane)

$$R - 80 \cos 30 = 0$$

so $R = 80 \cos 30$

$$F = \mu R = \frac{1}{\sqrt{12}} \times 80 \cos 30 = \frac{80 \cos 30}{\sqrt{12}} = 20$$

Newton's second law for the 12 kg ball (vertically downwards)

$$120 - T = 12a \dots\dots\dots [1]$$

Newton's second law for the 8 kg box (parallel to and up the plane)

$$T - F - 80 \sin 30 = 8a$$

$$T - 20 - 80 \sin 30 = 8a \dots\dots\dots [2]$$

[1] + [2] gives

$$120 - 20 - 80 \sin 30 = 20a$$

$$20a = 60$$

$$a = 3 \text{ m s}^{-2}$$

$$a = 3, u = 0, s = 1.5$$

Using $s = ut + \frac{1}{2}at^2$

$$1.5 = \frac{1}{2}(3)t^2$$

$$t^2 = 1$$

$$t = 1 \text{ s}$$

b From [1] $T = 120 - 12a$

$$T = 120 - 12 \times 3 = 120 - 36 = 84 \text{ N}$$

2

The diagram shows DF for the driving force, as the diagrams are the same for part a and part b apart from the value of DF changing from 400 N to 20 N.

a

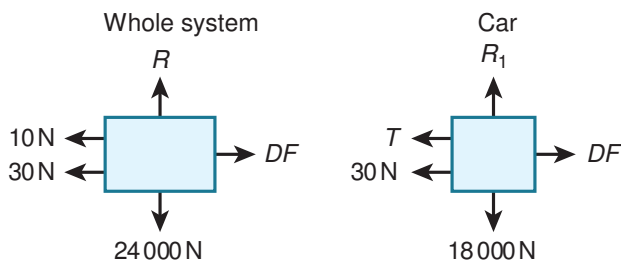

Newton's second law for the whole system

$$400 - 30 - 10 = (600 + 1800) a$$

$$360 = 2400a$$

$$a = 0.15 \text{ m s}^{-2}$$

Newton's second law for the car

$$400 - 30 - T = 1800a$$

$$370 - T = 1800 \times 0.15$$

$$370 - T = 270$$

$T = 100$ so a tension of 100 N

b Newton's second law for the whole system

$$20 - 30 - 10 = (600 + 1800) a$$

$$-20 = 2400a$$

$$a = -\frac{1}{120} \text{ m s}^{-2}$$

Newton's second law for the car

$$20 - 30 - T = 1800a$$

$$-10 - T = 1800 \times \left(-\frac{1}{120}\right)$$

$$-10 - T = -15$$

$T = 5$ so a tension of 5 N

3 a Newton's second law for the whole system (vertically downwards)

$$200 - 10 = (5 + 15) a$$

$$190 = 20a$$

$$a = 9.5 \text{ m s}^{-2}$$

b

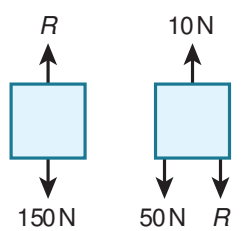

Newton's second law for the crate (vertically downwards)

$$150 - R = 15a$$

$$150 - R = 15 \times 9.5$$

$$150 - R = 142.5$$

$$R = 7.5 \text{ N}$$

4 a Newton's second law for the 0.6 kg particle (vertically downwards)

$$6 - T = 0.6a \dots\dots\dots [1]$$

Newton's second law for the 0.4 kg particle (vertically upwards)

$$T - 4 = 0.4a \dots\dots\dots [2]$$

[1] + [2] gives

$$6 - 4 = 1a$$

$$a = 2 \text{ m s}^{-2}$$

Apply Newton's second law separately to each particle to find the acceleration of the system, then use equations of constant acceleration to find the required speed.

P has to travel 0.25 m for Q to reach the pulley.

$$a = 2, u = 0, s = 0.25$$

Using $v^2 = u^2 + 2as$

$$v^2 = 0^2 + 2(2)(0.25) = 1$$

$$v = 1 \text{ m s}^{-1}$$

b The time it takes for Q to reach the pulley is found by

$$a = 2, u = 0, v = 1$$

Using $v = u + at$

$$1 = 2t$$

$$t = 0.5 \text{ s}$$

Then P has to travel $1.45 - 0.25 = 1.2 \text{ m}$ to reach the ground. During this motion, the string has become slack so P 's acceleration is now 10 m s^{-2}

$$a = 10, u = 1, s = 1.2$$

$$\text{Using } s = ut + \frac{1}{2}at^2$$

$$1.2 = 1t + \frac{1}{2}(10)t^2$$

$$5t^2 + t - 1.2 = 0$$

$$25t^2 + 5t - 6 = 0$$

$$(5t + 3)(5t - 2) = 0$$

$$t = -0.6, 0.4$$

$$\text{So } t = 0.4 \text{ s}$$

The total time for P to hit the ground is $0.5 + 0.4 = 0.9 \text{ s}$

The motion of P is in two stages, so you calculate the time for each separately. The first stage is when P is still attached to Q so the acceleration is still 2 m s^{-2} as in part a. Just before the second stage the string breaks, so the acceleration of P is now 10 m s^{-2} downwards.

5 a

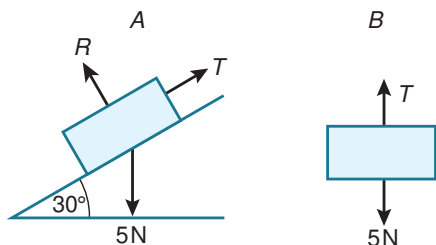

Newton's second law for B (vertically downwards)

$$5 - T = 0.5a \dots\dots\dots [1]$$

Newton's second law for A (parallel to and up the plane)

$$T - 5 \sin 30 = 0.5a$$

$$T - 2.5 = 0.5a \dots\dots\dots [2]$$

[1] + [2] gives

$$5 - 2.5 = a$$

$$a = 2.5 \text{ m s}^{-2}$$

b Find the velocity when B hits the ground

$$a = 2.5, u = 0, t = 1.2$$

$$\text{Using } v = u + at$$

$$v = 0 + 2.5(1.2) = 3 \text{ m s}^{-1}$$

Also, find the distance A has travelled when B hits the ground

$$a = 2.5, u = 0, t = 1.2$$

$$\text{Using } s = ut + \frac{1}{2}at^2$$

$$s = \frac{1}{2}(10)(1.2)^2$$

$$s = 1.8 \text{ m}$$

When B hits the ground, A 's velocity is 3 m s^{-1} , the string becomes slack.

To find A 's acceleration use Newton's second law for A (parallel to and up the plane)

$$-5 \sin 30 = 0.5a \text{ or } -0.5g \sin 30 = 0.5a$$

$$a = -5 \text{ m s}^{-2}, \text{ and when } A \text{ comes to instantaneous rest } v = 0$$

$$a = -5, v = 0, u = 3$$

$$\text{Using } v^2 = u^2 + 2as$$

$$0^2 = 3^2 + 2(-5)s$$

$$10s = 9$$

$$s = 0.9 \text{ m}$$

The total distance travelled by A is then $1.8 + 0.9 = 2.7 \text{ m}$

Notice when the string becomes slack, the only force acting on A in the direction of motion is A 's weight. You can write the acceleration of A as $-g \sin 30 \text{ m s}^{-2}$. This is independent of the mass of A which means a particle of any mass moving in the same way on this slope inclined at 30° to the horizontal will have the same acceleration as A .

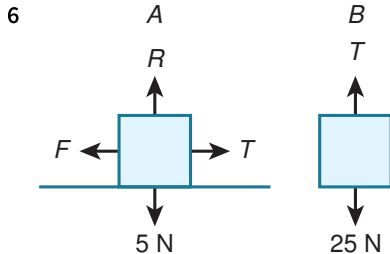

Newton's second law for particle A (vertically upwards)

$$R - 5 = 0$$

$$\text{so } R = 5$$

$$F = \mu R = 0.2 \times 5 = 1$$

Newton's second law for particle A (horizontally towards particle B)

$$T - F = 0.5a$$

$$T - 1 = 0.5a \dots\dots\dots [1]$$

Newton's second law for particle B (vertically downwards)

$$25 - T = 2.5a \dots\dots\dots [2]$$

[1] + [2] gives

$$25 - 1 = 3a$$

$$24 = 3a$$

$$a = 8 \text{ m s}^{-2}$$

Find the velocity when B hits the ground

$$a = 8, u = 0, s = 1$$

Using $v^2 = u^2 + 2as$

$$v^2 = 0^2 + 2(8)(1) = 16$$

$$v = 4 \text{ m s}^{-1}$$

Also, find the time it takes for B to hit the ground

$$a = 8, u = 0, s = 1, v = 4$$

Using $v = u + at$

$$4 = 0 + 8t$$

$$t = 0.5 \text{ s}$$

After B reaches the ground, there is no tension.

Newton's second law for particle A (horizontally towards particle B)

$$-F = 0.5a$$

$$-1 = 0.5a$$

$$a = -2 \text{ m s}^{-2}$$

When B hits the ground, A 's velocity is 4 m s^{-1} , the string becomes slack so A 's acceleration is now -2 m s^{-2} , and when A comes to instantaneous rest $v = 0$

$$a = -2, u = 4, v = 0$$

Using $v = u + at$

$$0 = 4 - 2t$$

$$t = 2 \text{ s}$$

The total time it takes A to come to instantaneous rest is $0.5 + 2 = 2.5$ s

Use Newton's second law to find the acceleration of each particle before B hits the ground. Find the time and the velocity of the particles when this happens.
 Then use Newton's second law to find the new acceleration when the string has gone slack. Use the velocity found previously to find the time for A to come to instantaneous rest.

- 7 a The pulleys are smooth, the crate and ball are modelled as particles, and the rope is light and inextensible. If the pulleys are not smooth they might 'stick' and the tension in the rope might be different on the two sides of the pulleys, but the second pulley would (probably) still not move.

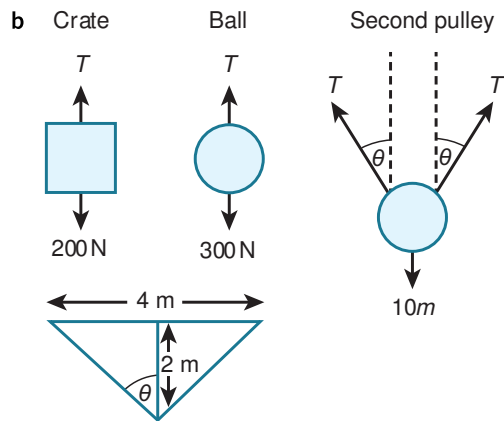

Newton's second law for the crate (vertically upwards)

$$T - 200 = 20a \dots\dots [1]$$

Newton's second law for the ball (vertically downwards)

$$300 - T = 30a \dots\dots [2]$$

[1] + [2] gives

$$\begin{aligned} 300 - 200 &= 50a \\ 100 &= 50a \\ a &= 2 \text{ m s}^{-2} \end{aligned}$$

From [1], $T = 20a + 200 = 20 \times 2 + 200 = 240$ N

Newton's second law for the middle pulley (vertically upwards)

$$T \cos \theta + T \cos \theta - 10m = 0$$

$$2T \cos \theta = 10m$$

$$\cos \theta = \frac{1}{\sqrt{2}}$$

$$\text{So } 2 \left(\frac{240}{\sqrt{2}} \right) = 10m$$

$$m = \frac{48}{\sqrt{2}} = 33.941 \dots = 33.9$$

You can find the value for $\cos \theta$ using the distance between the first and third pulleys and the vertical distance of the second pulley below them. This forms two isosceles right-angled triangles so that $\theta = 45^\circ$, or $\cos \theta = \frac{1}{\sqrt{2}}$

- 8 i Newton's second law for particle A (vertically upwards)

$$T_A - 2.5 = 0.25a$$

$$T_A = 2.5 + 0.25a \dots\dots [1]$$

Newton's second law for particle B (vertically downwards)

$$7.5 - T_B = 0.75a$$

$$T_B = 7.5 - 0.75a \dots\dots [2]$$

ii

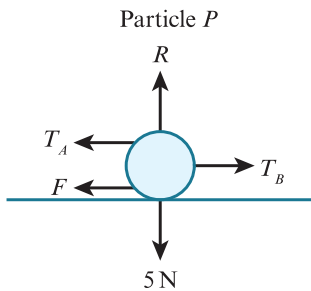

Newton's second law for particle P (vertically upwards)

$$R - 5 = 0 \text{ so } R = 5 \text{ N}$$

$$F = \mu R = 0.4 \times 5 = 2 \text{ N}$$

Newton's second law for particle P (horizontally to the right)

$$T_B - T_A - 2 = 0.5a$$

Substituting [1] and [2] gives

$$7.5 - 0.75a - (2.5 + 0.25a) - 2 = 0.5a$$

$$3 = 1.5a$$

$$a = 2 \text{ as required}$$

iii Immediately before B reaches the floor, the distance travelled is

$$1 - \frac{5.28 - 4}{2} = 1 - 0.64 = 0.36 \text{ m}$$

$$u = 0, s = 0.36, a = 2$$

Using $v^2 = u^2 + 2as$

$$v^2 = 0^2 + 2(2)(0.36) = 1.44$$

$$v = 1.2 \text{ m s}^{-1}$$

iv After B reaches the floor, $T_B = 0$ so Newton's second law for particle A (vertically upwards) stays the same

$$T_A - 2.5 = 0.25a \text{ [3]}$$

Newton's second law for particle P (horizontally to the right) changes to

$$-T_A - 2 = 0.5a \text{ [4]}$$

[3] + [4] gives

$$-4.5 = 0.75a$$

$$a = -6 \text{ so the deceleration of } P \text{ is } 6 \text{ m s}^{-2}$$

9

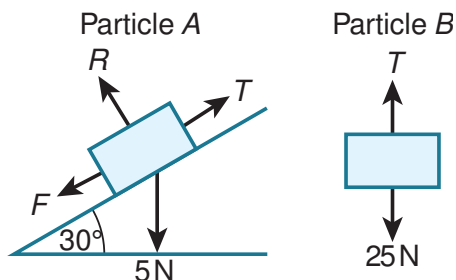

Newton's second law for particle A (perpendicular to the plane)

$$R - 5 \cos 30 = 0 \text{ so } R = 5 \cos 30$$

$$F = \mu R = 0.3 \times 5 \cos 30 = 1.5 \cos 30$$

Newton's second law for particle A (parallel to and up the plane)

$$T - F - 5 \sin 30 = 0.5a$$

$$\text{So } T - 1.5 \cos 30 - 5 \sin 30 = 0.5a \text{ [1]}$$

Newton's second law for particle B (vertically downwards)

$$25 - T = 2.5a \text{ [2]}$$

[1] + [2] gives

$$25 - 1.5 \cos 30 - 5 \sin 30 = 3a$$

$$a = 7.0669 \dots \text{ m s}^{-2}$$

When B reaches the ground, $s = 1 \text{ m}$

$$u = 0, s = 1, a = 7.0669 \dots$$

Using $v^2 = u^2 + 2as$

$$v^2 = 0^2 + 2(1)(7.0669 \dots) = 14.133 \dots$$

$$v = 3.759 \dots \text{ m s}^{-1}$$

When the string is cut, $T = 0$ so

Newton's second law for particle A (parallel to and up the plane) becomes

$$-F - 5 \sin 30 = 0.5a$$

$$\text{or } -1.5 \cos 30 - 5 \sin 30 = 0.5a$$

$$\text{so } a = -7.598 \dots \text{ m s}^{-2}$$

For this part of the motion, the initial speed is $u = 3.759 \dots$ and the final speed is $v = 0$

$$u = 3.759 \dots, v = 0, a = -7.598 \dots$$

Using $v^2 = u^2 + 2as$

$$0^2 = 3.759 \dots^2 + 2(-7.598 \dots)s$$

$$s = 0.9301 \dots \text{ m}$$

The total distance travelled by A is $1 + 0.9301 \dots = 1.9301 \dots = 1.93 \text{ m}$

The height of the pulley above the ground is $4 \sin 30 = 2 \text{ m}$

The length of the string that is hanging vertically is $2 - 1 = 1 \text{ m}$

The original distance of A from the pulley is $3 - 1 = 2 \text{ m}$

So as A only travels 1.93 m it does not reach the pulley.

Use Newton's second law to find the acceleration of each particle before B hits the ground. Find the velocity of the particles when this happens.

Then use Newton's second law to find the new acceleration when the string has been cut. Use the velocity found previously to find the distance A travels before it comes to instantaneous rest.

10 i

Apply Newton's second law separately to each particle to find the acceleration of the system, then use equations of constant acceleration to find the required speed.

Newton's second law for particle A (vertically upwards)

$$R - 2 = 0 \text{ so } R = 2 \text{ N}$$

$$F = \mu R = 0.3 \times 2 = 0.6 \text{ N}$$

Newton's second law for particle A (horizontally to the right)

$$T - F = 0.2a$$

$$T - 0.6 = 0.2a \dots\dots\dots [1]$$

Newton's second law for particle B (vertically downwards)

$$4.5 - T = 0.45a \dots\dots\dots [2]$$

[1] + [2] gives

$$4.5 - 0.6 = 0.65a$$

$$a = 6 \text{ m s}^{-2}$$

The distance travelled by particle B immediately before it hits the floor is $2 - (2.8 - 2.1) = 1.3 \text{ m}$

$$u = 0, s = 1.3, a = 6$$

Using $v^2 = u^2 + 2as$

$$v^2 = 0^2 + 2(1.3)(6) = 15.6$$

$$v = 3.949 \dots = 3.95 \text{ m s}^{-1} \text{ as required}$$

ii As B remains on the floor, $T = 0$ so Newton's second law for particle A (horizontally to the right) becomes

$$-F = 0.2a$$

$$-0.6 = 0.2a$$

$$a = -3 \text{ m s}^{-2}$$

Particle A has $2.1 - 1.3 = 0.8 \text{ m}$ to travel until it reaches the pulley.

$$u = 3.949\dots, s = 0.8, a = -3$$

$$\text{Using } v^2 = u^2 + 2as$$

$$v^2 = 3.949\dots^2 + 2(-3)(0.8) = 10.8$$

$$v = 3.286\dots = 3.29 \text{ m s}^{-1}$$

When the string breaks, $T = 0$ so the acceleration changes and needs recalculating.

11 i Newton's second law for particle A (vertically upwards)

$$R - 3 = 0 \text{ so } R = 3 \text{ N}$$

$$F = \mu R = 0.2 \times 3 = 0.6 \text{ N}$$

Newton's second law for particle A (horizontally to the right)

$$T - F = 0.3a$$

$$T - 0.6 = 0.3a \dots\dots [1]$$

Newton's second law for particle B (vertically downwards)

$$7 - T = 0.7a \dots\dots\dots [2]$$

[1] + [2] gives

$$7 - 0.6 = 1a$$

$$a = 6.4 \text{ m s}^{-2}$$

Find the distance travelled by B and B 's velocity just before the string breaks

$$u = 0, t = 0.25, a = 6.4$$

$$\text{Using } s = ut + \frac{1}{2}at^2$$

$$s = 0 + \frac{1}{2}(6.4)(0.25^2)$$

$$s = 0.2 \text{ m}$$

$$\text{Using } v = u + at$$

$$v = 0 + (6.4)(0.25) = 1.6 \text{ m s}^{-1}$$

After the string breaks, $T = 0$ so for B , $a = 10 \text{ m s}^{-2}$

B needs to travel $0.5 - 0.2 = 0.3 \text{ m}$ to reach the floor.

$$u = 1.6, s = 0.3, a = 10$$

$$\text{Using } v^2 = u^2 + 2as$$

$$v^2 = 1.6^2 + 2(10)(0.3) = 8.56$$

$$v = 2.925\dots = 2.93 \text{ m s}^{-1}$$

ii After the string breaks, Newton's second law for particle A (horizontally to the right) becomes

$$-F = 0.3a$$

$$-0.6 = 0.3a$$

$$a = -2 \text{ m s}^{-2}$$

To find the total distance travelled by A , we need to find how far A travels in this section of the motion until $v = 0$

$$u = 1.6, v = 0, a = -2$$

$$\text{Using } v^2 = u^2 + 2as$$

$$0^2 = 1.6^2 + 2(-2)s$$

$$s = 0.64 \text{ m}$$

So the total distance travelled by A is $0.2 + 0.64 = 0.84 \text{ m}$

12 a Just before B hits the pulley

$$u = 0, s = 0.6, t = 1$$

$$\text{Using } s = \frac{1}{2}(u + v)t$$

$$0.6 = \frac{1}{2}(0 + v)(1)$$

$$v = 1.2 \text{ m s}^{-1}$$

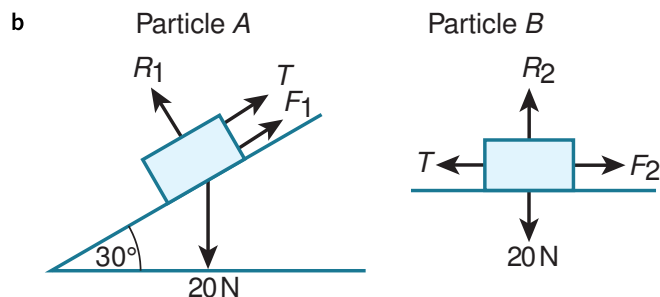

Begin by finding the acceleration of A

$$u = 0, s = 0.6, t = 1$$

$$\text{Using } s = ut + \frac{1}{2}at^2$$

$$0.6 = 0 + \frac{1}{2}a(1^2)$$

$$a = 1.2 \text{ m s}^{-2}$$

Newton's second law for particle A (perpendicular to the plane)

$$R_1 - 20 \cos 30 = 0 \text{ so } R_1 = 20 \cos 30 \text{ N}$$

$$F_1 = \mu R_1 = 0.2 \times 20 \cos 30 = 4 \cos 30 \text{ N}$$

Newton's second law for particle A (parallel to and down the plane)

$$20 \sin 30 - T - F_1 = 2a$$

$$20 \sin 30 - T - 4 \cos 30 = 2 \times 1.2$$

$$T = 20 \sin 30 - 4 \cos 30 - 2.4 = 4.1358 \dots = 4.14 \text{ N as required}$$

c Newton's second law for particle B (vertically)

$$R_2 - 20 = 0 \text{ so } R_2 = 20 \text{ N}$$

$$F_2 = \mu R_2 = 20\mu$$

Newton's second law for particle B (horizontally to the left)

$$T - F_2 = 2a$$

$$4.1358 \dots - 20\mu = 2 \times 1.2$$

$$20\mu = 1.735 \dots$$

$$\mu = 0.08679 \dots = 0.0868$$

d When the string breaks, $T = 0$ so the acceleration changes.

Newton's second law for particle A (parallel to and down the plane) becomes

$$20 \sin 30 - F_1 = 2a$$

$$20 \sin 30 - 4 \cos 30 = 2a$$

$$a = 3.267 \dots \text{ m s}^{-2}$$

From part **a**, $u = 1.2 \text{ m s}^{-1}$

The distance A still has to travel is $1 - 0.6 = 0.4 \text{ m}$

$$u = 1.2, s = 0.4, a = 3.267 \dots$$

$$\text{Using } v^2 = u^2 + 2as$$

$$v^2 = 1.2^2 + 2(3.267 \dots)(0.4) = 4.054 \dots$$

$$v = 2.0135 \dots = 2.01 \text{ m s}^{-1}$$

Chapter 6

General motion in a straight line

EXERCISE 6A

1 $s = 20t - 4$

$$v = \frac{ds}{dt} = 20$$

Numerical value, so a constant velocity of 20 m s^{-1}

2 $s = 2t^4 + 3t^2 + 10t$

$$v = \frac{ds}{dt} = 8t^3 + 6t + 10$$

When $t = 2$, $v = 8(2)^3 + 6(2) + 10 = 86 \text{ m s}^{-1}$

3 a The ball is modelled as a particle, so air resistance can be ignored.

b $s = -5t^2 + 20t$

$$v = \frac{ds}{dt} = -10t + 20$$

When $t = 0$, $v = 20 \text{ m s}^{-1}$

c Using $v = \frac{ds}{dt} = -10t + 20$

When $t = 2$, $v = 0 \text{ m s}^{-1}$

4 a $s = 0.5t^4 - t^2$

$$v = \frac{ds}{dt} = 2t^3 - 2t$$

When $t = 0$, $v = 0$ units per second

b Using $v = \frac{ds}{dt} = 2t^3 - 2t$

When $t = 1$, $v = 0$ units per second

c Using $v = \frac{ds}{dt} = 2t^3 - 2t$

When $t = 2$, $v = 12$ units per second

The question tells you t is only valid for $0 \leq t \leq 2$. As t is time, it would not make sense for it to be negative, and the position of the child must change for $t > 2$.

5 a $s = 3 + 4t - t^2$

When $t = 0$, $s = 3 + 4(0) - (0)^2 = 3$

So the particle starts 3 m from O .

The position the particle started from is the displacement of the particle when $t = 0$.

b $v = \frac{ds}{dt} = 4 - 2t$

$4 - 2t = 0$ occurs when $t = 2$

When $t = 2$, $s = 3 + 4(2) - (2)^2 = 7$ m from O .

The displacement of the particle at $t = 2$ is 7 m from O . However, this is not the same as the distance moved

by the particle in the first 2 seconds. The particle starts at a displacement of 3 m so the distance travelled is $7\text{ m} - 3\text{ m} = 4\text{ m}$.

6 a $s = -5t^2 + 8t$
 $s = 0$ when
 $-5t^2 + 8t = 0$
 $t(-5t + 8) = 0$
 $(t = 0), t = \frac{8}{5} = 1.6\text{ s}$

$s = 0$ at $t = 0$ and $t = 1.6$.

The second time that $s = 0$ is the time when the particle has returned to its starting point.

b $v = \frac{ds}{dt} = -10t + 8 = 0$
 $t = \frac{8}{10} = 0.8\text{ s}$
When $t = 0.8$, $s = -5(0.8)^2 + 8(0.8) = 3.2\text{ m}$

The phrase 'momentarily stationary' means $v = 0$. This is usually referred to as 'instantaneous rest', as seen in Question 5.

7 a Show that when $t = 2$, $v = 13$
 $s = 4t^2 - \sqrt{2t^3}$
Rewrite s as $s = 4t^2 - \sqrt{2}t^{\frac{3}{2}}$
 $v = \frac{ds}{dt} = 8t - \frac{3}{2}\sqrt{2}t^{\frac{1}{2}} = 8t - \frac{3\sqrt{2}t}{2}$
When $t = 2$, $v = 8(2) - \frac{3\sqrt{2}(2)}{2} = 13\text{ m s}^{-1}$ as required

b When $t = 2$, $s = 4(2)^2 - \sqrt{2(2)^3} = 12\text{ m}$

The stone takes 2 s to reach the bottom of the lake, so the depth of the lake is the displacement when $t = 2$.

8 a $s = 4t + t^2$
When $t = 16$,
 $s = 4(16) + 16^2 = 320\text{ m}$

Car A takes 16 seconds to finish the race so the distance from start to finish is the displacement when $t = 16$.

b $v = \frac{ds}{dt} = 4 + 2t$
When $t = 16$, $v = 4 + 2(16) = 36\text{ m s}^{-1}$

c $s = 1.2t^2$
When car B crosses the finish line, $s = 320$
 $1.2t^2 = 320, t = 16.3299\dots$
 $v = \frac{ds}{dt} = 2.4t$
When $t = 16.3299\dots$,
 $v = 2.4(16.3299\dots) = 39.19818\dots = 39.2\text{ m s}^{-1}$

d After 16 s, car B is at $s = 1.2(16)^2 = 307.2\text{ m}$ so is $320 - 307.2 = 12.8\text{ m}$ behind.

The winning car is A as it takes 16 s and car B takes 16.3299... s.

9 $s = 1.8t^2 - 0.3t^4$

$v = \frac{ds}{dt} = 3.6t - 1.2t^3$

When $v = 0$, $3.6t - 1.2t^3 = 0$ so $1.2t(3 - t^2) = 0$

$(t = 0), t = \sqrt{3}$

When $t = \sqrt{3}$, $s = 1.8(\sqrt{3})^2 - 0.3(\sqrt{3})^4 = 2.7 \text{ m}$

Find the time when $v = 0$, then find s at this time to find the distance between the two doors.

10 a $5(4)^2 = A\sqrt{4} + B(4)$

$80 = 2A + 4B$

$40 = A + 2B$

Displacement is continuous (the parachutist does not instantaneously move from one place to another), so when $t = 4$ you know that both $s = 5t^2$ and $s = A\sqrt{t} + Bt$. You can substitute $t = 4$ and equate these to give an equation involving A and B .

b $s = 5t^2$

$v = \frac{ds}{dt} = 10t$

When $t = 4$, $v = 10(4) = 40$

However, the speed of the parachute is immediately reduced by $x \text{ m s}^{-1}$, so the speed at this instant changes to $(40 - x) \text{ m s}^{-1}$.

$s = At^{\frac{1}{2}} + Bt$

$v = \frac{ds}{dt} = \frac{1}{2}At^{-\frac{1}{2}} + B$

When $t = 4$, $v = \frac{1}{2}A(4)^{-\frac{1}{2}} + B = 0.25A + B$

Hence $40 - x = 0.25A + B$

We can equate the two speeds found at $t = 4$ to show the required equation.

c s and v must be the same for both functions at $t = 25$.

Equating functions for s :

$s = \sqrt{25}A + 25B = 25C + 30$

So, $A + 5B = 5C + 6$

$s = Ct + 30$

$v = \frac{ds}{dt} = C$

Equating functions for v :

$v = \frac{1}{2}A(25)^{-\frac{1}{2}} + B = C$

So, $0.1A + B = C$ or $A + 10B = 10C$

Velocity is continuous at $t = 25$, as the speed of the parachutist is not instantaneously changed at this time.

d There are 4 equations in A , B and x

$A + 10B = 10C$[1]

$A + 5B = 5C + 6$[2]

$0.25A + B = 40 - x$[3]

$A + 2B = 40$[4]

Using [1] - 2[2]

$$\begin{aligned}
 A + 10B &= 10C \\
 2A + 10B &= 10C + 12 \\
 -A &= -12 \\
 A &= 12
 \end{aligned}$$

Using [4]

$$\begin{aligned}
 12 + 2B &= 40 \\
 B &= 14
 \end{aligned}$$

Using [3]

$$\begin{aligned}
 0.25(12) + 14 &= 40 - x \\
 x &= 23
 \end{aligned}$$

11 a $v = \frac{ds}{dt} = -2.4t^3 + 7.2t^2 - 7.2t + 2.4$

When $t = 0$, $v = 2.4$

v is positive when $t = 0$ so the particle starts moving in the positive direction.

t is the time for which the particle has been moving, so the particle starts moving at $t = 0$

b $v = 0$ when $-2.4t^3 + 7.2t^2 - 7.2t + 2.4 = 0$

Use an equation solver to find $t = 1$ or you may notice $v = 0$ when $t = 1$.

When $t = 1$,

$$s = -0.6 + 2.4 - 3.6 + 2.4 = 0.6 \text{ m}$$

So $OA = 0.6$

So $OB = -0.6$

Solve $-0.6t^4 + 2.4t^3 - 3.6t^2 + 2.4t = -0.6$ using an equation solver gives $t = 1 + \sqrt[4]{2}$

When $t = 1 + \sqrt[4]{2}$,

$$v = -2.4(1 + \sqrt[4]{2})^3 + 7.2(1 + \sqrt[4]{2})^2 - 7.2(1 + \sqrt[4]{2}) + 2.4$$

$$s = -4.0363 \dots = -4.04 \text{ m s}^{-1}$$

'Instantaneous rest' means when $v = 0$.

12 a $v = \frac{ds}{dt} = -0.04t^3 + 0.6t^2 - 2.64t + 3.2$

$$\text{When } t = 2, v = -0.04(2)^3 + 0.6(2)^2 - 2.64(2) + 3.2 = 0 \text{ m s}^{-1}$$

$$\text{When } t = 5, v = -0.04(5)^3 + 0.6(5)^2 - 2.64(5) + 3.2 = 0 \text{ m s}^{-1}$$

$$\text{When } t = 8, v = -0.04(8)^3 + 0.6(8)^2 - 2.64(8) + 3.2 = 0 \text{ m s}^{-1} \text{ as required.}$$

b As $v = 0$ when $t = 2, 5$ and 8 , you need to find s at these times as well as s when $t = 10$.

$$\text{When } t = 2, s = -0.01(2)^4 + 0.2(2)^3 - 1.32(2)^2 + 3.2(2) = 2.56$$

$$\text{When } t = 5, s = -0.01(5)^4 + 0.2(5)^3 - 1.32(5)^2 + 3.2(5) = 1.75$$

$$\text{When } t = 8, s = -0.01(8)^4 + 0.2(8)^3 - 1.32(8)^2 + 3.2(8) = 2.56$$

$$\text{When } t = 10, s = -0.01(10)^4 + 0.2(10)^3 - 1.32(10)^2 + 3.2(10) = 0$$

The distance travelled is $2.56 + (2.56 - 1.75) + (2.56 - 1.75) + 2.56 = 6.74 \text{ m}$

EXERCISE 6B

$$1 \quad v = 5t^2 - 20 = 0$$

$$t^2 = 4$$

$$t = 2 \text{ s}$$

Although the square root of 4 is ± 2 s, as you are finding time you ignore the value of -2 s as it makes no sense in relation to time. However, if you were calculating displacement or velocity you should consider both positive and negative values, as a negative value makes sense for both of these physical quantities.

$$2 \quad v = t^3 + 3t^2 - 8t + 1$$

$$a = \frac{dv}{dt} = 3t^2 + 6t - 8$$

$$\text{When } t = 2, a = 3(2)^2 + 6(2) - 8 = 16 \text{ m s}^{-2}$$

$$3 \text{ a } \quad v = 20 - 10t$$

$$a = \frac{dv}{dt} = -10 \text{ m s}^{-2}$$

b This is the acceleration due to gravity. It is negative because the upward direction is positive in this question.

$$4 \text{ a } \quad v = 5t + 0.5t^2$$

$$a = \frac{dv}{dt} = 5 + t$$

$$\text{When } t = 0, a = 5 \text{ m s}^{-2}$$

$$\text{b } \quad \text{When } t = 1, a = 5 + 1 = 6 \text{ m s}^{-2}$$

$$\text{c } \quad \text{When } t = 2, a = 5 + 2 = 7 \text{ m s}^{-2}$$

5 a As v is continuous at $t = 1.2$,

$$6 - 1.2^2 = 5 - \frac{1.2k}{30}$$

$$\frac{1.2k}{30} = 0.44$$

$$k = 11$$

b As the boy has velocity 0 m s^{-1} at time T ,

$$5 - \frac{11T}{30} = 0$$

$$T = \frac{150}{11} = 13.6\dot{3}$$

So T is just under 14 s

$$\text{c } \quad \text{Average acceleration} = \frac{\text{change in velocity}}{\text{time}}$$

$$= \frac{(\text{velocity at } t = T) - (\text{velocity at } t = 0)}{T}$$

$$= \frac{0 - 2}{\frac{150}{11}} = -\frac{11}{75} \text{ m s}^{-2} = -0.147 \text{ m s}^{-2}$$

$$\text{d } \quad \text{For } 0 \leq t \leq 1: a = \frac{dv}{dt} = 3 \text{ which is not equal to } -\frac{11}{75} \text{ m s}^{-2}$$

$$\text{For } 1 \leq t \leq 1.2: a = \frac{dv}{dt} = -2t \text{ which is equal to } -\frac{11}{75} \text{ when } t = \frac{11}{150} \text{ which is not in the range.}$$

$$\text{For } 1.2 \leq t \leq T: a = \frac{dv}{dt} = -\frac{k}{30} = -\frac{11}{30} \text{ which is not equal to } -\frac{11}{75} \text{ m s}^{-2}$$

So there is no time at which the acceleration of the boy is the same as his average acceleration.

6 a $s = 6t - t^2$

$$v = \frac{ds}{dt} = 6 - 2t \text{ m s}^{-1}$$

b It starts with speed 6 m s^{-1} but slows down and then stops and returns back the way it came, speeding up all the time.

c $v = 6 - 2t = 0$ when $t = 3\text{s}$

d $a = \frac{dv}{dt} = -2 \text{ m s}^{-2}$

7 $v = -t^3 + 75t$

$$a = \frac{dv}{dt} = -3t^2 + 75 = 0 \text{ when } t = 5$$

$$v = -(5)^3 + 75(5) = 250 \text{ m s}^{-1}$$

‘Maximum speed of the particle’ is usually when $a = 0$, as acceleration is the gradient of a velocity–time graph and a maximum point occurs when the gradient is zero. However, you should also test the end points of the range of times to see whether the speed is largest at either of these points.

For this question, time cannot be equal to 0 or 10, but looking at $t = 0$, gives $v = 0$ and $t = 10$ gives $v = -250$ or a speed of 250 m s^{-1} . As the time cannot reach 10, the maximum speed of the particle is 250 m s^{-1} found from setting $a = 0$.

8 $s = At^3 + Bt^2 + Ct$

$$v = \frac{ds}{dt} = 3At^2 + 2Bt + C$$

When $t = 0$, $v = 2$ so,

$$3A(0)^2 + 2B(0) + C = 2 \text{ so } C = 2$$

When $t = 3$, $v = 0$ so,

$$3A(3)^2 + 2B(3) + 2 = 0$$

$$27A + 6B + 2 = 0 \dots\dots\dots [1]$$

Also, when $t = 3$, $s = 6$ so,

$$A(3)^3 + B(3)^2 + 2(3) = 6$$

$$27A + 9B + 6 = 6$$

$$27A + 9B = 0 \dots\dots\dots [2]$$

$$[1] - [2] \text{ gives } -3B + 2 = 0$$

$$B = \frac{2}{3} \text{ and so } A = -\frac{2}{9}$$

‘Starts with velocity 2 m s^{-1} ’ means $v = 2$ when $t = 0$ and ‘Comes to rest at $t = 3$ ’ means $v = 0$ when $t = 3$.

9 a $s = 4t^2 - 0.25t^3$

$$v = \frac{ds}{dt} = 8t - 0.75t^2$$

$$a = \frac{dv}{dt} = 8 - 1.5t = 0 \text{ when } t = \frac{16}{3} \text{ s}$$

$$v = 8 \left(\frac{16}{3} \right) - 0.75 \left(\frac{16}{3} \right)^2 = 21.3 = 21.3 \text{ m s}^{-1}$$

For this question, time cannot be equal to 0 or 12, but looking at $t = 0$, gives $v = 0$ and $t = 12$ gives $v = -12$ or a speed of 12 m s^{-1} . Therefore the maximum speed of the particle is 21.3 m s^{-1} found from setting $a = 0$.

b The time when the speed is greatest is $\frac{16}{3} \text{ s}$

The time when the speed is least is when $v = 0$ at $t = 0$

$$\text{The time difference is } \frac{16}{3} - 0 = \frac{16}{3} \text{ s}$$

10 a When $t = 0$,

$$v = 5 + 4(0) - (0)^2 = 5 \text{ m s}^{-1}$$

'Initial velocity' is when $t = 0$.

$$\text{b } a = \frac{dv}{dt} = 4 - 2t = 0 \text{ when } t = 2 \text{ s}$$

$$v = 5 + 4(2) - (2)^2 = 9 \text{ m s}^{-1}$$

Here the maximum velocity of the particle is when $a = 0$, as the velocity–time graph is a negative quadratic, so the largest velocity will occur at the maximum turning point.

If you were asked to find the largest speed, you would have to check the end points of the range.

$$\text{c } \text{Average acceleration} = \frac{\text{change in velocity}}{\text{time}}$$

$$\text{When } t = 0, v = 5$$

$$\text{When } t = 5, v = 5 + 4(5) - (5)^2 = 0$$

$$\text{Average acceleration} = \frac{0 - 5}{5} = -1 \text{ m s}^{-2}$$

$$\text{11 a } s = t^2 - 2t^3 + 75t$$

$$v = \frac{ds}{dt} = 2t - 6t^2 + 75$$

$$a = \frac{dv}{dt} = 2 - 12t = 0 \text{ when } t = \frac{1}{6} \text{ hours}$$

$$t = 10 \text{ mins}$$

The fastest speed is when $a = 0$. You are told the train speeds up and then slows down, which means the maximum speed cannot be at the end points of the time.

$$\text{b } v \text{ when } t = \frac{1}{6}$$

$$v = 2 \left(\frac{1}{6} \right) - 6 \left(\frac{1}{6} \right)^2 + 75 = 75 \frac{1}{6} = 75.2 \text{ km h}^{-1}$$

$$\text{or } \frac{75 \frac{1}{6} \times 1000}{60^2} = 20.9 \text{ m s}^{-1}$$

$$\text{c } \text{Slows down when } t = \frac{1}{6} \text{ hour}$$

$$s = \left(\frac{1}{6} \right)^2 - 2 \left(\frac{1}{6} \right)^3 + 75 \left(\frac{1}{6} \right) = 12.5185 \dots = 12.5 \text{ km}$$

EXERCISE 6C

When integrating functions, you have a choice of how to deal with the constant of integration. One way is to use indefinite integration and include a constant of integration which you can find by substituting particular known values (for example, when $t = 0$, $s = 0$). Alternatively, you can use an upper and lower limit of time to perform definite integration.

1 $v = 5t^2 - 20$

$v = 0$ when $t = 2$

$$\begin{aligned} s &= \int v \, dt = \int_0^2 (5t^2 - 20) \, dt = \left[\frac{5t^3}{3} - 20t \right]_0^2 \\ &= \frac{5(2)^3}{3} - 20(2) - (0) \\ &= -\frac{80}{3} = -26.7 \text{ m} \end{aligned}$$

2 $s = \int v \, dt = \int_0^3 (t^3 + 3t^2 - 8t + 1) \, dt = \left[\frac{t^4}{4} + t^3 - 4t^2 + t \right]_0^3$
 $= \frac{(3)^4}{4} + 3^3 - 4(3)^2 + 3 = 14.25 \text{ m}$

3 When $v = 0$

$$\begin{aligned} 20 - 10t &= 0 \\ t &= 2 \end{aligned}$$

$$\begin{aligned} s &= \int v \, dt = \int_0^2 (20 - 10t) \, dt = [20t - 5t^2]_0^2 \\ &= 20(2) - 5(2)^2 = 20 \text{ m} \end{aligned}$$

4 a $s = \int v \, dt = \int (2t + t^2) \, dt = \left[t^2 + \frac{t^3}{3} \right]_0^0$
 When $t = 0$, $s = 0$

b When $t = 1$, $s = \left[t^2 + \frac{t^3}{3} \right]_0^1 = 1^2 + \frac{1^3}{3} = \frac{4}{3} = 1.33 \text{ m}$

c When $t = 2$, $s = \left[t^2 + \frac{t^3}{3} \right]_0^2 = 2^2 + \frac{2^3}{3} = \frac{20}{3} = 6.67 \text{ m}$

5 a Before the stone hits the water $t = 2$, $a = 10$, $u = 0$

Using $s = ut + \frac{1}{2}at^2$

$$s = 0 + \frac{1}{2}(10)(2)^2 = 20 \text{ m}$$

After the stone hits the water, $t = 2.5 - 2 = 0.5$

$$\begin{aligned} s &= \int v \, dt = \int (20 - t) \, dt = \left[20t - \frac{t^2}{2} \right]_0^{0.5} \\ &= 20(0.5) - \frac{0.5^2}{2} = 9.875 \text{ m} \end{aligned}$$

Depth of the well = $20 + 9.875 = 29.875 = 29.9 \text{ m}$

You should consider the motion of the stone in two parts; before and after the stone hits the water.

Before the stone hits the water, acceleration is constant, so you can use equations of constant acceleration (Chapter 1).

After the stone hits the water, $v = 20 - t$, so use integration to find s . Alternatively, you could differentiate to find $a = -1 \text{ m s}^{-2}$, showing the acceleration is again constant, and so again use equations of constant acceleration.

- b You would expect the depth of the well to be smaller if air resistance is taken into account.

If air resistance is taken into account, the deceleration would be greater, meaning the speed of descent would be slower. The stone would travel not as far as before in the same time, meaning the depth of the well would be smaller.

6 a $v = 13 - 10t - 3t^2 = 0$
 $(-3t - 13)(t - 1) = 0$ when $t = 1$ s

- b When $t = 1$,

$$s = \int v dt = \int_0^1 (13 - 10t - 3t^2) dt = [13t - 5t^2 - t^3]_0^1$$

$$= 13(1) - 5(1^2) - 1^3 = 7 \text{ cm}$$

c $s = \int v dt = \int 10T dT = 5T^2 + c$

When $T = 0$, $s = 0$ so $c = 0$

$$s = 5T^2$$

When $s = 7$, $5T^2 = 7$

$$T = \sqrt{\frac{7}{5}} = 1.1832\dots = 1.18 \text{ s}$$

- d There is no resistance on the downward journey, so, for example, the ball bearing does not touch the sides of the hole it has made. You could improve the model by incorporating a factor to represent friction.

7 a $s = \int v dt = \int_0^5 (-t^3 + 9t) dt = \left[-\frac{t^4}{4} + \frac{9t^2}{2}\right]_0^5$

$$= -\frac{(5)^4}{4} + \frac{9(5)^2}{2} = -43.75 = -43.8 \text{ m}$$

- b $v = 0$ when

$$-t^3 + 9t = 0$$

$$t(-t^2 + 9) = 0$$

$$(t = 0), t = 3$$

Find the distance in two separate calculations, from $t = 0$ to $t = 3$ and from $t = 3$ to $t = 5$

$$\text{When } t = 3, s = \left[-\frac{t^4}{4} + \frac{9t^2}{2}\right]_0^3$$

$$= -\frac{(3)^4}{4} + \frac{9(3)^2}{2} = 20.25 \text{ m}$$

$$\text{Total distance} = 20.25 + [20.25 - (-43.75)]$$

$$= 84.25 = 84.3 \text{ m}$$

You are asked to find the distance the particle travels, not the displacement. Therefore you need to consider the distance the particle travels in the positive direction and, separately, the distance travelled in the negative direction.

To find when the particle is travelling in each direction, find the times when $v = 0$. From $t = 0$ to $t = 3$, the particle travels 20.25 m in the positive direction.

You know from part a that the particle is at -43.75 m when $t = 5$ s.

From $t = 3$ to $t = 5$ the particle has travelled from $+20.25$ to -43.75 , a distance of $20.25 - (-43.75)$ m.

8 a $s = \int v dt = \int_0^{25} (16 - 0.5t^{1.5} + t) dt$

$$= \left[16t - \frac{0.5t^{2.5}}{2.5} + \frac{t^2}{2}\right]_0^{25}$$

$$= 16(25) - \frac{0.5(25)^{2.5}}{2.5} + \frac{(25)^2}{2} = 87.5 \text{ m}$$

- b $v = 0$ when

$$16 - 0.5t^{1.5} + t = 0$$

Using an equation solver, gives $t = 16$

Consider distances from $t = 0$ to $t = 16$ and from $t = 16$ to $t = 25$.

When $t = 0$, $s = 0$

$$\text{When } t = 16, s = 16(16) - \frac{0.5(16)^{2.5}}{2.5} + \frac{(16)^2}{2} = 179.2$$

When $t = 25$, from (a), $s = 87.5$ m

$$\text{Total distance} = 179.2 + (179.2 - 87.5) = 270.9 = 271 \text{ m}$$

Find when the car is momentarily at rest at $v = 0$, then find the distance in two separate calculations.

- 9 a As v is continuous at $t = 25$,

$$6 + 25^{0.5} = A - 25$$

$$6 + 5 = A - 25$$

$$A = 6 + 5 + 25 = 36 \text{ as required.}$$

b

The ball changes direction when $v = 0$.

Either $6 + t^{0.5} = 0$ which gives $t = 36$, not in this range

or $A - t = 0$ which gives $t = 36$

So the distance is given by

$$\begin{aligned} s &= \int_0^{25} v \, dt = \int_0^{25} (6 + t^{0.5}) \, dt \\ &= \left[6t + \frac{t^{1.5}}{1.5} \right]_0^{25} \\ &= 6(25) + \frac{25^{1.5}}{1.5} = 233.\dot{3} \end{aligned}$$

and

$$\begin{aligned} s &= \int_{25}^{36} v \, dt = \int_{25}^{36} (36 - t) \, dt \\ &= \left[36t - \frac{t^2}{2} \right]_{25}^{36} \\ &= 36(36) - \frac{36^2}{2} - \left(36(25) - \frac{25^2}{2} \right) = 60.5 \end{aligned}$$

$$\begin{aligned} \text{Total distance} &= 233.\dot{3} + 60.5 = 293.8\dot{3} \\ &= 294 \text{ m} \end{aligned}$$

- 10 a Maximum speed of the vehicle for $0 \leq t \leq 4$ is when $t = 4$ giving $v = 2(4) = 8$

Maximum speed of the vehicle for $4 \leq t \leq 10$ may occur when $a = 0$

$$v = 9 - (t - 5)^2$$

$$a = \frac{dv}{dt} = -2(t - 5) = 0 \text{ is when } t = 5 \text{ giving } v = 9 - (5 - 5)^2 = 9$$

However, at $t = 10$, $v = 9 - (10 - 5)^2 = -16$ giving a maximum speed of 16 m s^{-1} .

From the sketch of $v = 9 - (t - 5)^2$ for $4 \leq t \leq 10$, the maximum speed occurs when $t = 10$ s.

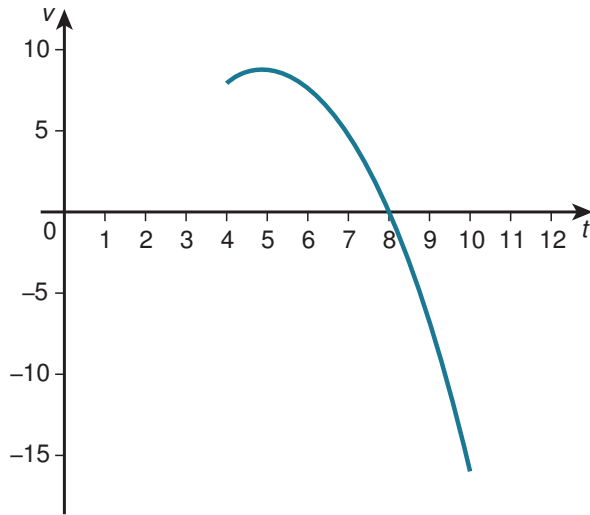

Here the maximum speed is at the end point of the range for t .

b $v = 0$ when

$$9 - (t - 5)^2 = 0$$

$$t - 5 = \pm 3$$

$t = 2$ (not in the range $4 \leq t \leq 10$) and $t = 8$

Find the distance in three separate calculations, from $t = 0$ to $t = 4$, from $t = 4$ to $t = 8$ and from $t = 8$ to $t = 10$.

So the distance is given by

$$s = \int v \, dt = \int_0^4 2t \, dt = [t^2]_0^4 = 4^2 = 16$$

and

$$s = \int v \, dt = \int_4^8 (9 - (t - 5)^2) \, dt$$

$$= \left[9t - \frac{(t - 5)^3}{3} \right]_4^8$$

$$= 9(8) - \frac{(8 - 5)^3}{3} - \left[9(4) - \frac{(4 - 5)^3}{3} \right]$$

$$= 26.\dot{6}$$

and

$$s = \int v \, dt = \int_8^{10} (9 - (t - 5)^2) \, dt$$

$$= \left[9t - \frac{(t - 5)^3}{3} \right]_8^{10}$$

$$= 9(10) - \frac{(10 - 5)^3}{3} - \left[9(8) - \frac{(8 - 5)^3}{3} \right]$$

$$= -14.\dot{6}$$

$$\text{Total distance} = 16 + 26.\dot{6} + 14.\dot{6} = 57.\dot{3}$$

$$= 57.3 \text{ m}$$

The motion of the particle is defined as two different functions. You need to consider each function separately. For $t = 0$ to $t = 4$, the velocity is a linear function so the particle travels in the same direction throughout this motion and you can find the distance travelled in one calculation.

However, the second function is a quadratic. Therefore you need to consider the distance the particle travels in the positive direction and, separately, the distance travelled in the negative direction.

To find when the particle is travelling in each direction, find the times when $v = 0$. From $t = 4$ to $t = 8$, the particle travels 26.6 m in the positive direction and from $t = 8$ to $t = 10$ the particle has travelled from +26.6 to -14.6, a distance of $26.6 - (-14.6)$ m.

By looking at the sketch, the area above the t -axis ($4 \leq t \leq 8$) is a positive displacement and the area below the t -axis ($8 \leq t \leq 10$) is a negative displacement.

- 11 a 1st car $t = 0, v = 0 \text{ m s}^{-1}$
 2nd car $t = 2, v = -16$ so speed = 16 m s^{-1}

Note the second car starts when $t = 2$.

- b $v = 0$ when $7.5t - 0.5t^2 = 0$

$$t(7.5 - 0.5t) = 0$$

$$(t = 0), t = 15 \text{ s}$$

$$\begin{aligned} s &= \int v \, dt = \int_0^{15} (7.5t - 0.5t^2) \, dt \\ &= \left[\frac{7.5t^2}{2} - \frac{0.5t^3}{3} \right]_0^{15} \\ &= \frac{7.5(15)^2}{2} - \frac{0.5(15)^3}{3} - (0) \\ &= 281.25 = 281 \text{ m} \end{aligned}$$

- c $v = 0$ when $(t - 2)^2 - 16 = 0$

$$t - 2 = 4$$

$$t = 6 \text{ s}$$

$$\begin{aligned} s &= \int v \, dt = \int_2^6 ((t - 2)^2 - 16) \, dt \\ &= \left[\frac{(t - 2)^3}{3} - 16t \right]_2^6 \\ &= \frac{(6 - 2)^3}{3} - 16(6) - \left[\frac{(2 - 2)^3}{3} - 16(2) \right] \\ &= -42.6 \end{aligned}$$

Giving a distance of 42.7 m

- d Car 1 stops after 15 s when $s = 281.25 \text{ m}$

Car 2 stops after 6 s when $s = -42.6 \text{ m}$

$$\text{When } t = 6, \text{ car 1 has travelled } \frac{7.5(6)^2}{2} - \frac{0.5(6)^3}{3} = 99 \text{ m}$$

The cars meet when car 1 has travelled $(300 - 42.6) = 257.3 \text{ m}$

The time when this occurs can be found from

$$\frac{7.5t^2}{2} - \frac{0.5t^3}{3} = 257.3$$

Using an equation solver gives $t = 12.308 \dots = 12.3 \text{ s}$

- 12 a As v is continuous at $t = 2$,

$$2 = 2k, k = 1$$

- b For $0 \leq t \leq 2, a = \frac{dv}{dt} = 1 \text{ m s}^{-2}$

$$\text{For } 2 \leq t \leq T, a = \frac{dv}{dt} = 1 - 0.055(2)(t - 2)$$

$$\text{When } t = 2, a = 1 - 0.055(2)(2 - 2) = 1 \text{ m s}^{-2}$$

So no change in acceleration when $t = 2$.

- c For $0 \leq t \leq 2, v_{\max} = 2 \text{ m s}^{-1}$

For $2 \leq t \leq T, v_{\max}$ occurs when $a = 0$

$$1 - 0.055(2)(t - 2) = 0 \text{ when } t = 11.09 \text{ s}$$

$$v_{\max} = 11.0\dot{9} - 0.055(11.0\dot{9} - 2)^2 = 6.5\dot{4} = 6.55 \text{ m s}^{-1}$$

You are told in the question the car starts and finishes at rest, so you do not need to consider the endpoints for the maximum velocity.

d Car stops when $v = 0$,

$$T - 0.055(T - 2)^2 = 0$$

$$0.055T^2 - 1.22T + 0.22 = 0$$

$$11T^2 - 244T + 44 = 0$$

$$(11T - 2)(T - 22) = 0$$

$$T = \frac{2}{11} \text{ (not in range), } T = 22$$

e For $0 \leq t \leq 2$,

$$s = \int v \, dt = \int_0^2 t \, dt = \left[\frac{t^2}{2} \right]_0^2 = \frac{2^2}{2} = 2 \text{ m}$$

and

For $2 \leq t \leq T$,

$$\begin{aligned} s &= \int v \, dt = \int_2^{22} (t - 0.055(t - 2)^2) \, dt \\ &= \left[\frac{t^2}{2} - 0.055 \frac{(t - 2)^3}{3} \right]_2^{22} \\ &= 242 - 146.\dot{6} = 93.\dot{3} \end{aligned}$$

$$\text{Total distance} = 2 + 93.\dot{3} = 95.\dot{3} = 95.3 \text{ m}$$

EXERCISE 6D

$$\begin{aligned}1 \quad v &= \int a \, dt = \int_0^2 (2t^4 + 3t^2 - 12t) \, dt \\ &= \left[\frac{2t^5}{5} + t^3 - 6t^2 \right]_0^2 \\ &= \frac{2(2)^5}{5} + 2^3 - 6(2)^2 = -3.2, \text{ so speed} \\ &= 3.2 \text{ m s}^{-1}\end{aligned}$$

$$2 \quad a = 10t - 4$$

$$a = 0 \text{ when } t = 0.4$$

$$v = \int a \, dt = \int (10t - 4) \, dt = 5t^2 - 4t + c$$

$$v = 15 \text{ when } t = 0, \text{ so } c = 15$$

$$v = 5t^2 - 4t + 15$$

$$\text{When } t = 0.4, v = 5(0.4)^2 - 4(0.4) + 15 = 14.2 \text{ m s}^{-1}$$

Minimum velocity occurs when $a = 0$.

$$3 \quad \text{a} \quad v = \int a \, dt = \int (2t^3 + 6t^2 - 18t) \, dt = \frac{t^4}{2} + 2t^3 - 9t^2 + c$$

$$v = 5 \text{ when } t = 0, \text{ so } c = 5$$

$$v = \frac{t^4}{2} + 2t^3 - 9t^2 + 5$$

$$\text{When } t = 3, v = \frac{3^4}{2} + 2(3)^3 - 9(3)^2 + 5 = 18.5 \text{ m s}^{-1}$$

$$\text{b} \quad s = \int v \, dt = \int_0^3 \left(\frac{t^4}{2} + 2t^3 - 9t^2 + 5 \right) \, dt$$

$$= \left[\frac{t^5}{10} + \frac{t^4}{2} - 3t^3 + 5t \right]_0^3$$

$$= \frac{3^5}{10} + \frac{3^4}{2} - 3(3)^3 + 5(3) = -1.2 \text{ m}$$

c As $v > 0$ when $t = 3$, the body is travelling in a positive direction from a negative position, so is travelling towards O .

$$4 \quad \text{a} \quad v = \int a \, dt = \int \left(\frac{1}{12}(9t^2 - 32t - 10) \right) \, dt$$

$$= \frac{1}{12}(3t^3 - 16t^2 - 10t) + c$$

$$v = 5 \text{ when } t = 0, \text{ so } c = 5$$

$$v = \frac{1}{12}(3t^3 - 16t^2 - 10t) + 5$$

$$\text{When } t = 2, v = \frac{1}{12}(3(2)^3 - 16(2)^2 - 10(2)) + 5$$

$$\frac{1}{12}(24 - 64 - 20) + 5 = -5 + 5 = 0 \text{ m s}^{-1} \text{ as required}$$

$$\begin{aligned}
 \text{b } s &= \int v \, dt = \int_0^2 \left(\frac{1}{12}(3t^3 - 16t^2 - 10t) + 5 \right) dt \\
 &= \left[\frac{1}{12} \left(\frac{3t^4}{4} - \frac{16t^3}{3} - 5t^2 \right) + 5t \right]_0^2 \\
 &= \frac{1}{12} \left(\frac{3(2)^4}{4} - \frac{16(2)^3}{3} - 5(2)^2 \right) + 5(2) \\
 &= 5\frac{7}{9} = 5.78 \text{ m}
 \end{aligned}$$

c When $t = 4.25$,

$$\begin{aligned}
 s &= \frac{1}{12} \left(\frac{3(4.25)^4}{4} - \frac{16(4.25)^3}{3} - 5(4.25)^2 \right) + 5(4.25) \\
 &= -0.003228 \dots \approx 0 \text{ m as required}
 \end{aligned}$$

d When $t = 4.25$, $v = \frac{1}{12}(3(4.25)^3 - 16(4.25)^2 - 10(4.25)) + 5 = -3.4335 \dots$ so speed = 3.43 m s^{-1}

$$5 \quad v = \int a \, dt = \int (0.01(10t - 3)) \, dt = 0.01(5t^2 - 3t) + c$$

$v = 0$ when $t = 0$, so $c = 0$

$$v = 0.01(5t^2 - 3t)$$

When $v = 2.24$,

$$0.01(5t^2 - 3t) = 2.24$$

$$5t^2 - 3t - 224 = 0$$

$(5t + 32)(t - 7) = 0$, giving $t = 7$ s

$$\begin{aligned}
 s &= \int v \, dt = \int_0^7 0.01(5t^2 - 3t) \, dt \\
 &= \left[0.01 \left(\frac{5t^3}{3} - \frac{3t^2}{2} \right) \right]_0^7 \\
 &= 0.01 \left(\frac{5(7)^3}{3} - \frac{3(7)^2}{2} \right) \\
 &= 4.98166 \dots = 4.98 \text{ m}
 \end{aligned}$$

$$6 \quad v = \int a \, dt = \int (0.01(4t + 3t^{0.5})) \, dt = 0.01 \left(2t^2 + \frac{3t^{1.5}}{1.5} \right) + c$$

$v = 0.5$ when $t = 1$, so $c = 0.46$

$$v = 0.01 \left(2t^2 + \frac{3t^{1.5}}{1.5} \right) + 0.46$$

$$\begin{aligned}
 s &= \int v \, dt = \int_0^4 \left(0.01 \left(2t^2 + \frac{3t^{1.5}}{1.5} \right) + 0.46 \right) dt \\
 &= \left[0.01 \left(\frac{2t^3}{3} + \frac{2t^{2.5}}{2.5} \right) + 0.46t \right]_0^4 \\
 &= 0.01 \left(\frac{2(4)^3}{3} + \frac{2(4)^{2.5}}{2.5} \right) + 0.46(4) \\
 &= 2.52266 \dots = 2.52 \text{ m}
 \end{aligned}$$

$$7 \quad \text{a } v = \int a \, dt = \int (40(t - 1)^3) \, dt = 10(t - 1)^4 + c$$

Minimum velocity is 0, and as $10(t - 1)^4$ can never be negative, we must have $c = 0$

$$v = 10(t - 1)^4$$

When $t = 1$, $v = 10(1 - 1)^4 = 0 \text{ m s}^{-1}$ as required

b When the particle is stationary, $t = 1$ (from part a)

$$\begin{aligned}
 s &= \int v \, dt = \int_0^1 (10(t - 1)^4) \, dt = \left[2(t - 1)^5 \right]_0^1 \\
 &= 2(1 - 1)^5 - 2(0 - 1)^5 = 0 - (-2) = 2 \text{ m}
 \end{aligned}$$

$$8 \quad v = \int a \, dt = \int (6t - c) \, dt = 3t^2 - ct + k$$

$$v = 0 \text{ when } t = 0, \text{ so } k = 0$$

$$v = 3t^2 - ct$$

Particle is stationary again when $3t^2 - ct = 0$

$$t(3t - c) = 0$$

$$(t = 0), t = \frac{c}{3}$$

$$s = \int v \, dt = \int_0^{\frac{c}{3}} (3t^2 - ct) \, dt = \left[t^3 - \frac{ct^2}{2} \right]_0^{\frac{c}{3}}$$

$$s = \left(\frac{c}{3}\right)^3 - \frac{c\left(\frac{c}{3}\right)^2}{2} = \frac{c^3}{27} - \frac{c^3}{18} = -\frac{c^3}{54}$$

$$\text{When } s = -4, -\frac{c^3}{54} = -4$$

$$\frac{c^3}{54} = 4, c^3 = 216, c = 6$$

9 For $0 \leq t < 6$

$$a = 0.1t^2(6 - t)$$

$$v = \int a \, dt = \int (0.1(6t^2 - t^3)) \, dt = 0.1 \left(2t^3 - \frac{t^4}{4} \right) + c$$

$$v = 0 \text{ when } t = 0, \text{ so } c = 0$$

$$v = 0.1 \left(2t^3 - \frac{t^4}{4} \right)$$

$$\begin{aligned} s &= \int v \, dt = \int_0^6 \left(0.1 \left(2t^3 - \frac{t^4}{4} \right) \right) \, dt \\ &= \left[0.1 \left(\frac{t^4}{2} - \frac{t^5}{20} \right) \right]_0^6 \\ &= 0.1 \left(\frac{6^4}{2} - \frac{6^5}{20} \right) = 25.92 \text{ m} \end{aligned}$$

Also, when $t = 6$,

$$v = 0.1 \left(2(6)^3 - \frac{(6)^4}{4} \right) = 10.8 \text{ m s}^{-1}$$

For $6 \leq t < 156$:

$$s = 10.8 \times (156 - 6) = 1620 \text{ m}$$

For $156 \leq t < 165$

$$s = \frac{10.8 \times (165 - 156)}{2} = 48.6 \text{ m}$$

$$\begin{aligned} \text{Total distance} &= 25.92 + 1620 + 48.6 = 1694.52 \\ &= 1690 \text{ m} \end{aligned}$$

The motion of the particle is defined as three different functions, so consider each function separately.

For $t = 0$ to $t = 6$, the acceleration is variable so you must integrate to find the distance travelled. Note $v = 0$ only when $t = 0$ in this time interval, so you can integrate from $t = 0$ to $t = 6$ in one go.

For $t = 6$ to $t = 156$, the velocity is constant so you can find the distance travelled as the area of a rectangle on a velocity–time graph.

For $t = 156$ to $t = 165$, the deceleration is constant so you can find the distance travelled either as the area of a triangle on a velocity–time graph or by using equations of constant acceleration.

10 a v is at a maximum when $a = 0$

$$a = 0 \text{ when}$$

$$5 - 2t = 0$$

$$t = 2.5 \text{ s}$$

$$v = \int a \, dt = \int (5 - 2t) \, dt = 5t - t^2 + c$$

$$v = 5t - t^2 + c$$

$$\text{When } t = 2.5, v = 26.01$$

$$5(2.5) - 2.5^2 + c = 26.01$$

$$c = 19.76$$

$$v = 5t - t^2 + 19.76$$

$$\text{When } t = 0, v = 5(0) - 0^2 = 19.76 = 19.8 \text{ ms}^{-1}$$

b When $v = 0$, $5t - t^2 + 19.76 = 0$

$$t = \frac{-5 \pm \sqrt{5^2 - 4(-1)(19.76)}}{2(-1)}$$

$$= -2.6, 7.6$$

$$t = 7.6 \text{ s}$$

c $s = \int v \, dt = \int_0^4 (t^2 - 16) \, dt$

$$= \left[\frac{t^3}{3} - 16t \right]_0^4$$

$$= \frac{4^3}{3} - 16(4) = -42\frac{2}{3}$$

So the second car travels for 42.7 m

The second car stops when $v = 0$, so $t^2 - 16 = 0$ and so $t = 4$ s.

d For the first car,

$$s = \int v \, dt = \int_0^{7.6} (5t - t^2 + 19.76) \, dt$$

$$= \left[\frac{5t^2}{2} - \frac{t^3}{3} + 19.76t \right]_0^{7.6}$$

$$= \frac{5(7.6)^2}{2} - \frac{7.6^3}{3} + 19.76(7.6)$$

$$= 148.2506 \dots$$

Second car travels for $42\frac{2}{3}$ m

Total distance = $148.2506 \dots + 42\frac{2}{3} = 191$ m, which is less than 200 m.

11 a $v = \int a \, dt = \int -0.03t^2 \, dt = -0.01t^3 + c$

$$v = 40 \text{ when } t = 0, \text{ so } c = 40$$

$$v = -0.01t^3 + 40$$

$$s = \int v \, dt = \int_0^2 (-0.01t^3 + 40) \, dt$$

$$= \left[-\frac{0.01t^4}{4} + 40t \right]_0^2$$

$$= -\frac{0.01(2)^4}{4} + 40(2) = 79.96 = 80.0 \text{ m}$$

b When $t = 2$, $v = -0.01(2)^3 + 40 = 39.92 = 39.9 \text{ ms}^{-1}$

c v changes so it becomes $-0.01t^3 - 30$

$$s \text{ changes so it becomes } -\frac{0.01t^4}{4} - 30t$$

$$\text{When } s = -79.96,$$

$$-\frac{0.01t^4}{4} - 30t = -79.96$$

Using an equation solver gives $t = 2.66115 \dots = 2.66$ s

12 a $R = mg = 10$ m

$$Fr = \mu R = 0.01(10 \text{ m}) = 0.1 \text{ m}$$

Using $F = ma$

$$-0.1m - m(0.9 + 1.5t) = ma$$

$$-0.1 - 0.9 - 1.5t = a$$

$$a = -1.5t - 1$$

$$v = \int a \, dt = \int (-1.5t - 1) \, dt = -0.75t^2 - t + C$$

$$v = -0.75t^2 - t + C$$

b When $t = 0, v = 8$ so $C = 8$

$$v = -0.75t^2 - t + 8$$

$$s = \int v \, dt = \int (-0.75t^2 - t + 8) \, dt = -0.25t^3 - \frac{t^2}{2} + 8t$$

$$\text{When } s = 7.25, -0.25t^3 - \frac{t^2}{2} + 8t = 7.25$$

$$-0.25t^3 - \frac{t^2}{2} + 8t - 7.25 = 0$$

Using an equation solver gives solutions of $t = 4.09, t = 1$ and $t = -7.09$.

We also know that the ball's final velocity is 6.25, so

$$6.25 = -0.75t^2 - t + 8$$

$$-0.75t^2 - t + 1.75 = 0$$

This has solutions $t = -2.33$ and $t = 1$.

$t = 1$ s is the only value that satisfies both equations.

- c** According to the model there is still air resistance when the ball comes to the end of the alley, but the ball will stop when it reaches the end of the skittle alley.

END-OF-CHAPTER REVIEW EXERCISE 6

$$1 \quad v = \int a \, dt = \int (-0.01t) \, dt = -0.005t^2 + c$$

When $t = 0$, $v = 2$ so $c = 2$

$$v = -0.005t^2 + 2$$

At rest when $v = 0$

$$-0.005t^2 + 2 = 0$$

$$t^2 = 400, t = 20 \text{ s}$$

$$\begin{aligned} s &= \int v \, dt = \int_0^{20} (-0.005t^2 + 2) \, dt = \left[-\frac{0.005t^3}{3} + 2t \right]_0^{20} \\ &= -\frac{0.005(20)^3}{3} + 2(20) = 26.\dot{6} = 26.7 \text{ m} \end{aligned}$$

$$2 \quad \text{a} \quad v = t^{0.5} - 0.8$$

$$a = \frac{dv}{dt} = 0.5t^{-0.5}, \text{ when } t = 16, a = 0.125 \text{ m s}^{-2}$$

b For $0 \leq t \leq 16$:

$$u = 0, t = 16, a = 0.2$$

$$\text{Using } s = ut + \frac{1}{2}at^2$$

$$s = 0(16) + \frac{1}{2}(0.2)(16^2) = 25.6 \text{ m}$$

For $16 < t \leq 36$:

$$\begin{aligned} s &= \int v \, dt = \int_{16}^{36} (t^{0.5} - 0.8) \, dt = \left[\frac{t^{1.5}}{1.5} - 0.8t \right]_{16}^{36} \\ &= 144 - 28.8 - (42.\dot{6} - 12.8) = 85.\dot{3} \text{ m} \end{aligned}$$

$$\text{Total distance} = 25.6 + 85.\dot{3} = 110.9\dot{3} = 111 \text{ m}$$

You could also find the distance travelled between $t = 16$ and $t = 36$ by indefinite integration. Include a constant of integration and find this by using $s = 25.6$ when $t = 16$. Then find the displacement when $t = 36$.

3 a Speed immediately before collision

$$v = 1.2(20) - 0.03(20^2) = 12 \text{ m s}^{-1}$$

Speed immediately after collision

$$v = 0.3(20) - 9 = -3$$

$$\text{So speed} = 3 \text{ m s}^{-1}$$

b For $0 \leq t \leq 20$

$$\begin{aligned} s &= \int v \, dt = \int_0^{20} (1.2t - 0.03t^2) \, dt = [0.6t^2 - 0.01t^3]_0^{20} \\ &= 0.6(20)^2 - 0.01(20)^3 \\ &= 160 \end{aligned}$$

For $20 \leq t \leq 30$

$$\begin{aligned} s &= \int v \, dt = \int_{20}^{30} (0.3t - 9) \, dt = [0.15t^2 - 9t]_{20}^{30} \\ &= 0.15(30)^2 - 9(30) - [0.15(20)^2 - 9(20)] \\ &= -135 - (-120) \\ &= -15 \end{aligned}$$

$$\text{Total distance} = 160 + 15 = 175 \text{ m}$$

4 a Maximum velocity for $0 \leq t \leq 10$ is when $t = 10$, so $v = 0.8(10) = 8 \text{ m s}^{-1}$

For $10 \leq t \leq 50$, write s as $s = 7t - 100t^{-1} - 20$

$$v = \frac{ds}{dt} = 7 + 100t^{-2} = 7 + \frac{100}{t^2}$$

This is a maximum when t is as small as possible.

When $t = 10$,

$$v = 7 + \frac{100}{10^2} = 8 \text{ m s}^{-1}$$

So $v_{\max} = 8 \text{ m s}^{-1}$

b For $0 \leq t \leq 10$, $a = \frac{dv}{dt} = 0.8 \text{ m s}^{-2}$

For $10 \leq t \leq 50$, $a = \frac{dv}{dt} = -200t^{-3} = -\frac{200}{t^3}$

When $t = 10$, $a = -\frac{200}{10^3} = -0.2 \text{ m s}^{-2}$

Change in acceleration $= -0.2 - 0.8 = -1$

So acceleration has reduced by 1 m s^{-2} as required

5 $v = \int a dt = \int (9000t) dt = 4500t^2 + c$

When $t = 0$, $v = 0$ so $c = 0$

$$v = 4500t^2$$

When $4500t^2 = 28125$, $t = 2.5 \text{ s}$

$$s = \int v dt = \int_0^{2.5} (4500t^2) dt = [1500t^3]_0^{2.5}$$

$$= 1500(2.5)^3 = 23437.5 = 23400 \text{ m or } 23.4 \text{ km}$$

6 a $a = 0.1 - 0.01t = 0$ when $t = 10 \text{ s}$

$$v = \int a dt = \int (0.1 - 0.01t) dt = 0.1t - 0.005t^2 + c$$

When $t = 0$, $v = 4$ so $c = 4$

$$v = 0.1t - 0.005t^2 + 4$$

When $t = 10$, $v = 0.1(10) - 0.005(10)^2 + 4 = 4.5 \text{ m s}^{-1}$

b When $v = 0$, $0.1t - 0.005t^2 + 4 = 0$

$$t^2 - 20t - 800 = 0$$

$$(t - 40)(t + 20) = 0$$

$$t = 40 \text{ s}$$

7 a As a is continuous at $t = 1$,

$$A(1 + 4) = B(30 - 10)$$

$$5A = 20B$$

$$A = 4B \text{ as required}$$

b For $0 \leq t \leq 1$

$$v = \int a dt = \int A(1 + 4t) dt = A(t + 2t^2) + c$$

When $t = 0$, $v = 0$ so $c = 0$

$$v = A(t + 2t^2)$$

When $t = 1$, $v = A(1 + 2) = 3A$

For $1 \leq t \leq 5$

$$v = \int a dt = \int B(30 - 10t^{-3}) dt = B(30t + 5t^{-2}) + c$$

When $t = 5$, $v = 31.8$ so $c = 31.8 - 150.2B$

$$v = B(30t + 5t^{-2}) + 31.8 - 150.2B$$

When $t = 1$, $v = B(30 + 5) + 31.8 - 150.2B = 31.8 - 115.2B$

As v is continuous at $t = 1$,

$$3A = 31.8 - 115.2B$$

From (a) $A = 4B$

$$\text{So } 12B = 31.8 - 115.2B$$

$$127.2B = 31.8$$

$$B = 0.25$$

$$A = 4B = 4(0.25) = 1 \text{ as required}$$

c For $0 \leq t \leq 1$

$$\begin{aligned} s &= \int v \, dt = \int_0^1 (t + 2t^2) \, dt = \left[\frac{t^2}{2} + \frac{2t^3}{3} \right]_0^1 \\ &= \frac{1^2}{2} + \frac{2(1)^3}{3} = \frac{7}{6} \end{aligned}$$

For $1 \leq t \leq 5$, from part **b**

$$v = B(30t + 5t^{-2}) + c$$

$$B = 0.25 \text{ and so } c = 31.8 - 150.2B = -5.75$$

$$v = 0.25(30t + 5t^{-2}) - 5.75$$

$$\begin{aligned} s &= \int v \, dt = \int_1^5 (0.25(30t + 5t^{-2}) - 5.75) \, dt = [0.25(15t^2 - 5t^{-1}) - 5.75t]_1^5 \\ &= 64.75 - (-3.25) = 68 \end{aligned}$$

$$\text{Total distance } \frac{7}{6} + 68 = 69\frac{1}{6} = 69.2 \text{ m}$$

d The gradient of the acceleration–time graph changes suddenly at $t = 1$, which means the velocity of the car instantaneously changes. This would not happen in real life.

8 i At $t = 8$, $v = \frac{1}{2}t^{\frac{2}{3}}$ and $a = \frac{1}{3}t^{-\frac{1}{3}} = \frac{1}{36}(8)^{-\frac{1}{3}} = \frac{1}{6} \text{ m s}^{-2}$

Acceleration before P passed through A was $\frac{1}{4}$

$$\frac{1}{4} - \frac{1}{6} = \frac{1}{12}, \text{ so the acceleration has decreased by } \frac{1}{12} \text{ m s}^{-2}$$

ii For $0 \leq t \leq 8$

$$a = \frac{1}{4}, u = 0, t = 8$$

$$\text{Using } s = ut + \frac{1}{2}at^2$$

$$s = \frac{1}{2} \left(\frac{1}{4} \right) 8^2 = 8 \text{ m}$$

For $8 \leq t \leq 27$

$$\begin{aligned} s &= \int v \, dt = \int_8^{27} \left(\frac{1}{2}t^{\frac{2}{3}} \right) \, dt = \left[\frac{3}{10}t^{\frac{5}{3}} \right]_8^{27} \\ &= \frac{3}{10}(27)^{\frac{5}{3}} - \frac{3}{10}(8)^{\frac{5}{3}} = 63.3 \text{ m} \end{aligned}$$

$$\text{Total distance} = 8 + 63.3 = 71.3 \text{ m}$$

9 a $v = \int a \, dt = \int (-0.6t) \, dt = -0.3t^2 + c$

When $t = 0$, $v = 14$ so $c = 14$

$$v = -0.3t^2 + 14$$

$$\begin{aligned} s &= \int v \, dt = \int_0^{t_1} (-0.3t^2 + 14) \, dt = [-0.1t^3 + 14t]_0^{t_1} = 57.5 \\ -0.1t_1^3 + 14t_1 &= 57.5 \end{aligned}$$

Using an equation solver gives $t_1 = 5 \text{ s}$

$$\text{When } t = 5, v = -0.3(5)^2 + 14 = 6.5 \text{ m s}^{-1}$$

$$\text{b } -0.3t^2 + 14 = 0$$

$$t = 6.8313 \dots$$

$$\text{When } t = 6.8313 \dots, s = -0.1(6.8313 \dots)^3 + 14(6.8313 \dots) = 63.7588 \dots = 63.8 \text{ m}$$

$$\text{c } \text{When } s = 40$$

$$-0.1t^3 + 14t = 40$$

$$\text{Using an equation solver gives } t = 65 - \sqrt{5} = 3.06225 \dots = 3.06 \text{ s}$$

$$\text{10 i } v = \int a \, dt = \int (0.05 - 0.0002t) \, dt = 0.05t - 0.0001t^2 + c$$

$$\text{When } t = 0, v = 0 \text{ so } c = 0$$

$$v = 0.05t - 0.0001t^2$$

$$\text{When } t = 200$$

$$v = 0.05(200) - 0.0001(200)^2 = 6 \text{ m s}^{-1}$$

$$\text{When } t = 500$$

$$v = 0.05(500) - 0.0001(500)^2 = 0 \text{ m s}^{-1}$$

$$\text{ii } \text{Distance covered by } A$$

$$\begin{aligned} s &= \int v \, dt = \int_0^{500} (0.05t - 0.0001t^2) \, dt = \left[\frac{0.05t^2}{2} - \frac{0.0001t^3}{3} \right]_0^{500} \\ &= \frac{0.05(500)^2}{2} - \frac{0.0001(500)^3}{3} = 2083.3 \text{ m} \end{aligned}$$

$$\text{Distance covered by } B = \frac{500 \times 6}{2} = 1500 \text{ m}$$

$$\text{Distance between } A \text{ and } B = 2083.3 - 1500 = 583.3 = 583 \text{ m}$$

As particle B moves with constant acceleration followed by constant deceleration, the velocity–time graph of this particle is a triangle with base 500 (total time) and height 6 (v when $t = 200$, found in part **a**). The area of the triangle gives the distance covered by B .

$$\text{11 i } s = \int v \, dt = \int_0^{15} A(t - 0.05t^2) \, dt = \left[A \left(\frac{t^2}{2} - \frac{0.05t^3}{3} \right) \right]_0^{15} = 225$$

$$A \left(\frac{(15)^2}{2} - \frac{0.05(15)^3}{3} \right) = 225$$

$$56.25A = 225$$

$$A = 4$$

$$\text{As } v \text{ is continuous at } t = 15$$

$$4[15 - 0.05(15)^2] = \frac{B}{15^2}$$

$$4(3.75) = \frac{B}{225}$$

$$B = 3375$$

$$\text{ii } s = \int v \, dt = \int (3375t^{-2}) \, dt = -3375t^{-1} + c$$

$$\text{When } t = 15, s = 225$$

$$-3375(15)^{-1} + c = 225$$

$$c = 450$$

$$s = \left(450 - \frac{3375}{t} \right) \text{ m}$$

$$\text{iii } \text{When } s = 315$$

$$450 - \frac{3375}{t} = 315$$

$$\frac{3375}{t} = 135$$

$$t = 25 \text{ s}$$

$$\text{When } t = 25, v = \frac{3375}{25^2} = 5.4 \text{ m s}^{-1}$$

12 a $u = 2, a = 0.1, t = 10$

$$\text{Using } s = ut + \frac{1}{2}at^2$$

$$s = 2(10) + \frac{1}{2}(0.1)(10)^2 = 25 \text{ m}$$

b $u = 2, a = 0.1, t = 10$

$$\text{Using } v = u + at$$

$$v = 2 + 0.1(10) = 3 \text{ m s}^{-1}$$

c When $t = 10$

$$v_1 = 0.003(10)^2 + 0.06(10) + k = 3$$

$$0.3 + 0.6 + k = 3$$

$$k = 2.1$$

d $v_2 = 0$ when $4 - 0.1t = 0$

$$t = 40 \text{ s}$$

$$\begin{aligned} s &= \int v \, dt = \int_{10}^{40} (4 - 0.1t) \, dt = \left[4t - \frac{0.1t^2}{2} \right]_{10}^{40} \\ &= 4(40) - \frac{0.1(40)^2}{2} - \left[4(10) - \frac{0.1(10)^2}{2} \right] = 45 \text{ m} \end{aligned}$$

$$\text{Distance from } A \text{ to } C = 25 + 45 = 70 \text{ m}$$

e $s = \int v \, dt = \int_{10}^{40} (0.4t - 0.01t^2) \, dt = \left[0.2t^2 - \frac{0.01t^3}{3} \right]_{10}^{40}$

$$= 0.2(40)^2 - \frac{0.01(40)^3}{3} - \left(0.2(10)^2 - \frac{0.01(10)^3}{3} \right)$$
$$= 90 \text{ m}$$

So Q can travel 90 m in the same time it takes P to travel 45 m, so Q reaches C first.

CROSS-TOPIC REVIEW EXERCISE 2

- 1 a Newton's second law for B (vertically downwards)

$$60 - T = 6a \dots\dots\dots [1]$$

Newton's second law for A (vertically upwards)

$$T - 40 = 4a \dots\dots\dots [2]$$

[1] + [2] gives

$$60 - 40 = 10a$$

$$20 = 10a$$

$$a = 2 \text{ m s}^{-2}$$

From [2], $T = 4a + 40 = 4 \times 2 + 40 = 48 \text{ N}$

- b The magnitude of the resultant force exerted on the pulley is $2T = 2 \times 48 = 96 \text{ N}$

- 2 Component of weight down the slope is $30 \sin 27 = 13.619 \dots$

Component of pulling force up the slope = $5 \cos 10 = 4.924 \dots$

As $30 \sin 27 > 5 \cos 10$ it means the particle is about to slip down the slope, so friction acts up the slope.

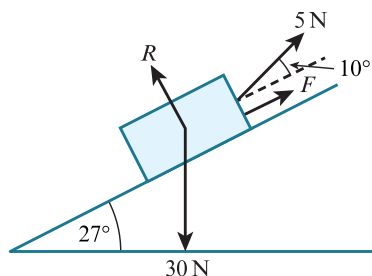

Newton's second law (perpendicular to the plane)

$$R - 30 \cos 27 + 5 \sin 10 = 0$$

$$\text{so } R = 30 \cos 27 - 5 \sin 10$$

$$F = \mu R = (30 \cos 27 - 5 \sin 10) \mu$$

Newton's second law (parallel to and down plane)

$$30 \sin 27 - 5 \cos 10 - F = 0$$

$$30 \sin 27 - 5 \cos 10 - (30 \cos 27 - 5 \sin 10) \mu = 0$$

$$(30 \cos 27 - 5 \sin 10) \mu = 30 \sin 27 - 5 \cos 10$$

$$\mu = \frac{30 \sin 27 - 5 \cos 10}{30 \cos 27 - 5 \sin 10} = 0.33623 \dots = 0.336$$

Note both the weight and the pulling force have components both parallel and perpendicular to the slope.

- 3 **Particle P** **Particle Q**

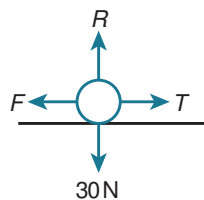

Newton's second law for P (vertically)

$$R - 30 = 0$$

$$\text{so } R = 30$$

$$F = \mu R = 0.4 \times 30 = 12 \text{ N}$$

Newton's second law for P (horizontally to the right)

$$T - F = 3a$$

$$T - 12 = 3a \dots\dots\dots [1]$$

Newton's second law for Q (vertically downwards)

$$50 - T = 5a \dots\dots\dots [2]$$

[1] + [2] gives

$$\begin{aligned} 50 - 12 &= 8a \\ 38 &= 8a \\ a &= 4.75 \text{ m s}^{-2} \end{aligned}$$

Particle P hits the pulley when $s = 0.8 \text{ m}$

$$u = 0, s = 0.8, a = 4.75$$

$$\text{Using } s = ut + \frac{1}{2}at^2$$

$$0.8 = 0 + \frac{1}{2}(4.75)t^2$$

$$t^2 = 0.3368\dots$$

$$t = 0.5803\dots = 0.580\text{s}$$

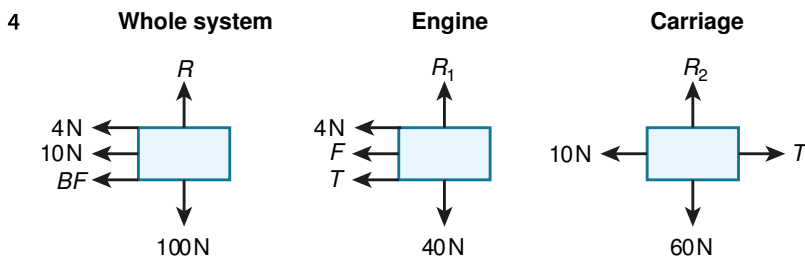

Newton's second law for the whole system

$$\begin{aligned} -4 - 10 - BF &= (4 + 6) \times (-2) \\ -14 - BF &= -20 \\ BF &= 6 \text{ N} \end{aligned}$$

Newton's second law for the engine

$$\begin{aligned} -4 - BF - T &= 4 \times (-2) \\ -4 - 6 - T &= -8 \end{aligned}$$

$T = -2$ so the force in the tow-bar is 2 N and is a compression.

Instead of using Newton's second law for the engine you could use Newton's second law for the carriage and this would again give a compression of 2 N.

5 a When $t = 1, v = 27 \text{ m s}^{-1}$

When $t = 5, v = 7.668\dots \text{ m s}^{-1}$

$$v = 3t^{0.5} + \frac{24}{t^2} = 3t^{0.5} + 24t^{-2}$$

$$a = \frac{dv}{dt} = 1.5t^{-0.5} - 48t^{-3}$$

When $a = 0,$

$$1.5t^{-0.5} - 48t^{-3} = 0$$

Multiply by t^3

$$1.5t^{2.5} - 48 = 0$$

$$t^{2.5} = 32$$

$$\sqrt{t^5} = 32$$

$$t = \sqrt[5]{32^2} = 4\text{s}$$

When $t = 4, v = 7.5$

This is lower than at the end points of the range of times so $v_{\min} = 7.5 \text{ m s}^{-1}$

'Minimum velocity of the particle' is usually when $a = 0$, as acceleration is the gradient of a velocity-time graph and a minimum point occurs when the gradient is zero. However, you should also test the end points of the range of times to see whether the speed is smaller at either of these points than where the acceleration is zero.

- b v must be the same for both functions at $t = 1$

$$\text{so } k = 3 + \frac{24}{1} = 27$$

$$\begin{aligned} s &= \int v \, dt = \int_0^1 27 \, dt + \int_1^4 \left(3t^{\frac{1}{2}} + \frac{24}{t^2} \right) dt = [27t]_0^1 + \left[\frac{3t^{1.5}}{1.5} - 24t^{-1} \right]_1^4 \\ &= 27 + [2(4)^{1.5} - 24(4)^{-1}] - [2(1)^{1.5} - 24(1)^{-1}] \\ &= 27 + 16 - 6 - (2 - 24) = 59 \text{ m} \end{aligned}$$

Velocity is continuous at $t = 1$, as the speed of the particle is not instantaneously changed at this time.

- 6 a

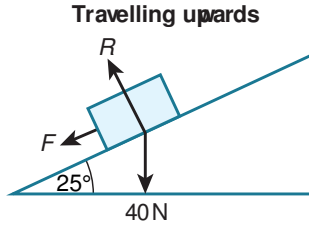

Newton's second law (perpendicular to the plane)

$$R - 40 \cos 25 = 0$$

$$\text{so } R = 40 \cos 25$$

$$F = \mu R = 0.4 \times 40 \cos 25 = 16 \cos 25$$

Newton's second law (parallel to and up plane)

$$-40 \sin 25 - F = 4a$$

$$-40 \sin 25 - 16 \cos 25 = 4a$$

$$a = -7.851\dots$$

$$a = -7.851\dots, u = 5, v = 0$$

Using $v^2 = u^2 + 2as$

$$0^2 = 5^2 + 2(-7.851\dots)s$$

$$s = 1.592\dots = 1.59 \text{ m}$$

- b The time taken for the particle to come to rest is given by

$$a = -7.851\dots, u = 5, v = 0$$

Using $v = u + at$

$$0 = 5 - 7.851\dots t$$

$$t = 0.6368\dots \text{s}$$

Newton's second law (parallel to and down plane)

$$40 \sin 25 - F = 4a$$

$$40 \sin 25 - 16 \cos 25 = 4a$$

$$a = 0.6009\dots$$

$$a = 0.6009\dots, u = 0, s = 1.592\dots$$

Using $s = ut + \frac{1}{2}at^2$

$$1.592\dots = 0 + \frac{1}{2}(0.6009\dots)t^2$$

$$t^2 = 5.298\dots$$

$$t = 2.3017\dots \text{s}$$

The total time for the particle to return to A is $0.6368\dots + 2.3017\dots = 2.938\dots = 2.94 \text{ s}$

Notice that the time it takes the particle to move back to A is not double the time it takes the particle to come to rest, as the acceleration has a different magnitude. Use Newton's second law again to find the new acceleration when the particle is moving down the slope.

Remember that friction acts in the opposite direction when the particle moves down the slope; this is the reason for the difference in magnitude of the acceleration.

- 7 a Maximum value of the velocity is when $a = 0$

$$v = 12t + t^3 - 0.3t^5$$

$$a = \frac{dv}{dt} = 12 + 3t^2 - 1.5t^4$$

When $a = 0$,

$$12 + 3t^2 - 1.5t^4 = 0$$

Solve for t^2 using $\frac{-b \pm \sqrt{b^2 - 4ac}}{2a}$

$$t^2 = \frac{-3 \pm \sqrt{3^2 - 4(-1.5)(12)}}{2(-1.5)} = 4$$

$$t = 2\text{s}$$

When solving the quadratic in t^2 you are only interested in the positive square root, as $t^2 = -2$ has no real solutions.

You could have factorised or completed the square instead, as the equation is a quadratic in t^2 . Using the quadratic formula is just one way to solve the equation.

Find s when $t = 2\text{s}$

$$v = 12t + t^3 - 0.3t^5$$

$$\begin{aligned} s &= \int v \, dt = \int_0^2 (12t + t^3 - 0.3t^5) \, dt = \left[6t^2 + \frac{t^4}{4} - \frac{0.3t^6}{6} \right]_0^2 \\ &= \left[6(2)^2 + \frac{(2)^4}{4} - \frac{0.3(2)^6}{6} \right] = 24.8 \text{ m} \end{aligned}$$

- b When the particles collide, s is the same for both. For particle P

$$s = \int v \, dt = \int (12t + t^3 - 0.3t^5) \, dt = 6t^2 + \frac{t^4}{4} - \frac{0.3t^6}{6} + c$$

When $t = 0$, $s = 0$ so $c = 0$

$$s = 6t^2 + \frac{t^4}{4} - \frac{0.3t^6}{6}$$

At time T

$$6T^2 + \frac{T^4}{4} - \frac{0.3T^6}{6} = 74.25 - 0.05T^6$$

$$\frac{T^4}{4} + 6T^2 - 74.25 = 0$$

Solve for T^2 using $\frac{-b \pm \sqrt{b^2 - 4ac}}{2a}$

$$T^2 = \frac{-6 \pm \sqrt{6^2 - 4(0.25)(-74.25)}}{2(0.25)} = 9$$

$$T = 3\text{s}$$

Rather than using the quadratic formula, you could instead use:

$$T^4 - 24T^2 - 297 = 0$$

$$(T^2 - 9)(T^2 + 33) = 0$$

$$T^2 = 9 \text{ so } T = 3\text{s}$$

- 8 a Newton's second law for A (vertically downwards)

$$80 - T = 8a \dots\dots\dots [1]$$

Newton's second law for B (vertically upwards)

$$T - 50 = 5a \dots\dots\dots [2]$$

[1] + [2] gives

$$80 - 50 = 13a$$

$$30 = 13a$$

$$a = \frac{30}{13} \text{ m s}^{-2}$$

Find v when A hits the ground, this can then be used as u for B 's subsequent motion.

$$a = \frac{30}{13}, u = 0, s = 1.2$$

$$\text{Using } v^2 = u^2 + 2as$$

$$v^2 = 0^2 + 2 \left(\frac{30}{13} \right) (1.2)$$

$$v^2 = 5.538\dots$$

$$v = 2.353\dots$$

For B 's motion when A hits the ground, the tension is now zero and acceleration is -10 m s^{-2} using upwards as positive

$$a = -10, u = 2.353\dots, v = 0$$

$$\text{Using } v^2 = u^2 + 2as$$

$$0^2 = 2.353^2 + 2(-10)s$$

$$s = 0.2769\dots$$

The maximum height reached by B is $0.2769\dots + 2 \times 1.2 = 2.676\dots = 2.68 \text{ m}$

Particle B begins 1.2 m above the ground and reaches a further 1.2 m above the ground when A hits the ground.

b

There are three times to consider. The time for A to reach the ground, the time for B to reach the maximum height from when the string is cut and the time for B to reach the ground from the maximum height.

Time for A to reach the ground

$$a = \frac{30}{13}, u = 0, s = 1.2$$

$$\text{Using } s = ut + \frac{1}{2}at^2$$

$$1.2 = 0 + \frac{1}{2} \left(\frac{30}{13} \right) t^2$$

$$t^2 = 1.04$$

$$t = 1.0198\dots \text{s}$$

Time for B to reach the maximum height from when the string is cut, taking upwards as positive

$$a = -10, v = 0, u = 2.353\dots$$

$$\text{Using } v = u + at$$

$$0 = 2.353\dots - 10t$$

$$t = 0.2353\dots \text{s}$$

Time for B to reach the ground from the maximum height, taking downwards as positive $a = 10, u = 0,$

$$s = 2.676\dots$$

$$\text{Using } s = ut + \frac{1}{2}at^2$$

$$2.676\dots = 0 + \frac{1}{2}(10)t^2$$

$$t = 0.73169\dots \text{s}$$

The total time = $1.0198\dots + 0.2353\dots + 0.7316\dots = 1.9868\dots = 1.99 \text{ s}$

9 a The particle is first stationary when $v = 0$

$$s = 0.12t + 10 - 0.01t^3$$

$$v = \frac{ds}{dt} = 0.12 - 0.03t^2$$

$$\text{When } v = 0, 0.12 - 0.03t^2 = 0$$

$$0.03t^2 = 0.12$$

$$t^2 = 4$$

$$t = 2\text{s}$$

- b** The total distance travelled in the first 10 s needs finding in two separate blocks, between $t = 0$ and $t = 2\text{s}$ and between $t = 2$ and $t = 10\text{s}$

$$\text{When } t = 0, s = 0.12 \times 0 + 10 - 0.01 \times 0^3 = 10$$

$$\text{When } t = 2, s = 0.12 \times 2 + 10 - 0.01 \times 2^3 = 10.16$$

$$\text{When } t = 10, s = 0.12 \times 10 + 10 - 0.01 \times 10^3 = 1.2$$

$$\text{So the distance travelled is } |10.16 - 10| + |1.2 - 10.16| = 0.16 + 8.96 = 9.12\text{ m}$$

As P and Q come to rest alongside each other, you know from part **a** that for both particles when $t = 2, s = 10.16, v = 0$

- c** For P and also for Q , when $t = 2, s = 10.16, v = 0$

$$a = 0.4 - 0.06t$$

$$v = \int a \, dt = \int (0.4 - 0.06t) \, dt = 0.4t - 0.03t^2 + c$$

$$\text{When } t = 2, v = 0$$

$$\text{so } 0.4(2) - 0.03(2)^2 + c = 0$$

$$c = -0.68$$

$$v = 0.4t - 0.03t^2 - 0.68$$

$$s = \int v \, dt = \int (0.4t - 0.03t^2 - 0.68) \, dt = 0.2t^2 - 0.01t^3 - 0.68t + c$$

$$\text{When } t = 2, s = 10.16$$

$$\text{so } 0.2(2)^2 - 0.01(2)^3 - 0.68(2) + c = 10.16$$

$$c = 10.8$$

$$s = 0.2t^2 - 0.01t^3 - 0.68t + 10.8$$

$$\text{When } t = 10, s = 0.2(10)^2 - 0.01(10)^3 - 0.68(10) + 10.8 = 14\text{ m}$$

10 10 kg mass

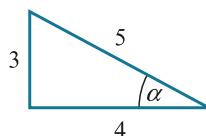
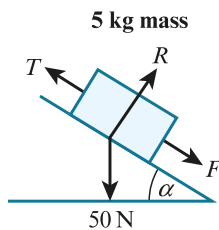

$$\tan \alpha = \frac{3}{4}, \text{ so from the right-angled } 3, 4, 5 \text{ triangle: } \sin \alpha = \frac{3}{5}, \cos \alpha = \frac{4}{5}$$

Notice that the value of α has not been calculated. In fact, this should be avoided as it can lead to premature approximations and rounding errors.

Newton's second law for the 5 kg mass (perpendicular to the plane)

$$R - 50 \cos \alpha = 0 \text{ so } R = 50 \cos \alpha = 50 \left(\frac{4}{5} \right) = 40$$

$$F = \mu R = 0.5 \times 40 = 20$$

Newton's second law for the 5 kg mass (parallel to and up the plane)

$$T - F - 50 \sin \alpha = 5a$$

$$\text{So } T - 20 - 30 = 5a \dots\dots [1]$$

Newton's second law for the 10 kg mass (vertically downwards)

$$100 - T = 10a \dots\dots\dots [2]$$

[1] + [2] gives

$$100 - 20 - 30 = 15a$$

$$a = 3. \dot{3} = 3.33 \text{ m s}^{-2}$$

From [1] $T = 5a + 50 = 5 \times 3. \dot{3} + 50 = 66. \dot{6} = 66.7 \text{ N}$

11 i

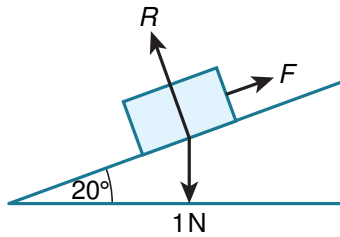

$$u = 0, t = 5, v = 2$$

Using $v = u + at$

$$2 = 0 + 5a$$

$$a = 0.4 \text{ m s}^{-2}$$

Newton's second law (parallel to and down the plane)

$$1 \sin 20 - F = 0.1a$$

$$\sin 20 - F = 0.1 \times 0.4 = 0.04$$

$$F = \sin 20 - 0.04 = 0.30202 \dots = 0.302 \text{ as required}$$

ii Newton's second law (perpendicular to the plane)

$$R - 1 \cos 20 = 0 \text{ so } R = \cos 20$$

$$F = \mu R$$

$$\text{so } 0.30202 \dots = \mu \cos 20$$

$$\mu = 0.32140 \dots = 0.321$$

12 i $v = 6t^2 - 30t + 24$

$$a = \frac{dv}{dt} = 12t - 30$$

When $a < 0$,

$$12t - 30 < 0$$

$$t < 2.5$$

ii When P is at instantaneous rest, $v = 0$

$$v = 6t^2 - 30t + 24 = 0$$

$$t^2 - 5t + 4 = 0$$

$$(t - 1)(t - 4) = 0$$

$$t = 1, 4$$

$$\begin{aligned} s &= \int_1^4 v \, dt = \int_1^4 (6t^2 - 30t + 24) \, dt = [2t^3 - 15t^2 + 24t]_1^4 \\ &= 2(4)^3 - 15(4)^2 + 24(4) - [2(1)^3 - 15(1)^2 + 24(1)] \\ &= -27 \end{aligned}$$

So the distance travelled is 27 m

iii When $s = 0$, $2t^3 - 15t^2 + 24t = 0$

$$2t^3 - 15t^2 + 24t = 0$$

$$t(2t^2 - 15t + 24) = 0$$

$$t = 0, t = \frac{15 \pm \sqrt{15^2 - 4(2)(24)}}{2(2)}$$

$$t = \frac{15 \pm \sqrt{33}}{4}$$

So $t = 0$ (not a positive value), $t = 5.186 \dots$, $2.3138 \dots$

$$t = 5.19 \text{ and } 2.31$$

13 Newton's second law for P (vertically downwards)

$$9 - 7.2 = 0.9a$$

$$0.9a = 1.8$$

$$a = 2 \text{ m s}^{-2}$$

Find v^2 when P hits the ground

$$u = 0, a = 2, s = 2$$

$$\text{Using } v^2 = u^2 + 2as$$

$$v^2 = 0^2 + 2(2)(2) = 8$$

You do not need to find v when P hits the ground, it can be left as v^2 as this is used in the next equation of motion as u^2 .

After P hits the ground, $T = 0$ and $a = -10$ taking upwards as positive

Find the distance travelled by Q until it reaches instantaneous rest

$$v = 0, a = -10, u^2 = 8$$

$$\text{Using } v^2 = u^2 + 2as$$

$$0^2 = 8 + 2(-10)s$$

$$s = 0.4$$

The total distance travelled by Q from the instant it first reaches X until it returns to X is $2 \times 0.4 = 0.8 \text{ m}$

Chapter 7

Momentum

EXERCISE 7A

- 1 Momentum = $mv = 10 \times 8 = 80 \text{ Ns}$
- 2 Momentum = $mv = 1500 \times 22 = 33000 \text{ Ns}$
- 3 $57g = 0.057 \text{ kg}$

$$180 \text{ kmh}^{-1} = \frac{(180 \times 1000)}{(60 \times 60)} = 50 \text{ m s}^{-1}$$

$$\text{Momentum} = mv = 0.057 \times 50 = 2.85 \text{ Ns}$$

Remember to work in SI units. You should convert any units at the start.

- 4 $40 \text{ g} = 0.04 \text{ kg}$
Momentum before = $0.04 \times 2.2 = 0.088 \text{ Ns}$
Momentum after = $0.04 \times 0.8 = 0.032 \text{ Ns}$
Decrease in momentum = $0.088 - 0.032 = 0.056 \text{ Ns}$
- 5 Initial momentum = $4 \times 3 = 12 \text{ Ns}$
Final momentum = $4 \times -6 = -24 \text{ Ns}$
Change in momentum = $12 - (-24) = 36 \text{ Ns}$

Note the rock has changed direction. The velocity changes sign and the momentum of the rock is negative just before the rock lands.

- 6 a $u = 0, a = 10, s = 2.45$
Using $v^2 = u^2 + 2as$
 $v^2 = 0 + 2(10)(2.45) = 49$
 $v = \pm 7$
So speed = 7 m s^{-1}

Use equations of constant acceleration to find the speed of the girl when she lands on the beach. Note that you were asked for speed, so you use the positive value of the velocity. If the question asked for velocity, you would need to consider the situation to decide whether the positive or the negative value is the most appropriate.

- b Momentum = $mv = 35 \times 7 = 245 \text{ Ns}$
- 7 a $u = 0, a = 10, s = 1.8$
Using $v^2 = u^2 + 2as$
 $v^2 = 0 + 2(10)(1.8) = 36$
 $v = 6 \text{ m s}^{-1}$
b Momentum = $mv = 2 \times 6 = 12 \text{ Ns}$
- 8 a $u = 0, a = 10, s = 1.25$
Using $v^2 = u^2 + 2as$
 $v^2 = 2(10)(1.25) = 25$
 $v = 5 \text{ m s}^{-1}$

The momentum of the ball when it is about to hit the ground is $mv = 0.2 \times 5 = 1 \text{ Ns}$

The momentum of the ball just after it hits the ground is $1 - 1.6 = -0.6 \text{ Ns}$

Velocity of the ball just after it hits the ground is

$$\frac{-0.6}{0.2} = -3 \text{ m s}^{-1}$$

When the ball reaches its greatest height, $v = 0$

$$u = -3, a = 10, v = 0$$

Using $v^2 = u^2 + 2as$

$$0^2 = (-3)^2 + 2(10)s$$

$$s = -0.45 \text{ m}$$

The ball has been displaced 0.45 m upwards, so the height of the ball is 0.45 m.

Begin by finding the momentum of the ball when it is about to hit the ground.

- b The ball is modelled as a particle with no size and it is assumed there is no air resistance. Air resistance would slow the ball, so it would have a smaller velocity when it reaches the ground and consequently a smaller velocity after the bounce. If the ball has size then the centre of the ball does not reach the ground so the distance travelled is reduced and again this will reduce the velocity after the bounce. A reduced rebound velocity will reduce the height reached.

9 $25g = 0.025 \text{ kg}$

Initial momentum = $0.025 \times 3 = 0.075 \text{ Ns}$

Final momentum = $0.025 \times -2 = -0.05 \text{ Ns}$

Change in momentum = $0.075 - (-0.05) = 0.125 \text{ Ns}$

10 $a = -0.5 - kt$

$$v = \int a \, dt = \int (-0.5 - kt) \, dt = -0.5t - \frac{kt^2}{2} + c$$

When $t = 0, v = 8$ so $c = 8$

$$v = -0.5t - \frac{kt^2}{2} + 8$$

$$\begin{aligned} s &= \int v \, dt = \int_0^2 \left(-0.5t - \frac{kt^2}{2} + 8 \right) dt \\ &= \left[-0.25t^2 - \frac{kt^3}{6} + 8t \right]_0^2 = \frac{41}{3} \\ -0.25(2)^2 - \frac{k(2)^3}{6} + 8(2) &= \frac{41}{3} \\ k &= 1 \end{aligned}$$

So $v = -0.5t - \frac{t^2}{2} + 8$

Just before the hit:

$$v = -0.5(2) - \frac{(2)^2}{2} + 8 = 5 \text{ m s}^{-1}$$

Momentum before = $0.2 \times 5 = 1 \text{ Ns}$

Momentum after = $0.2 \times -5 = -1 \text{ Ns}$

Change in momentum = $1 - (-1) = 2 \text{ Ns}$ as required

Use integration to find an expression for the velocity and then the displacement of the hockey ball. Use the displacement expression and $s = \frac{41}{3}$ when $t = 1$ to find k .

Note that the direction of the ball changes after it is hit by the second player so the velocity becomes negative.

11 Loss in momentum for particle $A = (5 \times 2) - (5 \times 0) = 10 \text{ Ns}$

So gain in momentum for particle $B = 10 \text{ Ns}$

As B is initially stationary $2v = 10$

$$v = 5$$

As the speed is stated as $v \text{ m s}^{-1}$, the value of v is 5 rather than 5 m s^{-1}

- 12 Let the distance the ball travels before it reaches the first cushion be x .

Find the velocity just before the ball strikes the first cushion

$$u = 10, a = -1, s = x$$

Using $v^2 = u^2 + 2as$

$$v^2 = 10^2 + 2(-1)x$$

$$v^2 = 100 - 2x$$

$$v = \sqrt{100 - 2x}$$

As the magnitude of the momentum after the rebound is 50% of the magnitude of the momentum before, and the mass does not alter, the velocity after the rebound is half the velocity before the rebound. It has the opposite sign as the ball is now travelling in the opposite direction.

$$\text{So, } u = -\frac{\sqrt{100 - 2x}}{2}$$

Find the velocity just before the ball strikes the second cushion

$$u = -\frac{\sqrt{100 - 2x}}{2}, a = -1, s = 3.5$$

Using $v^2 = u^2 + 2as$

$$v^2 = \left(-\frac{\sqrt{100 - 2x}}{2}\right)^2 + 2(-1)(3.5)$$

$$v^2 = \frac{100 - 2x}{4} - 7 = \frac{36 - x}{2}$$

$$v = -\sqrt{\frac{36 - x}{2}}$$

To be consistent with direction, take the negative square root for the velocity just before the rebound.

As the magnitude of the momentum after the rebound is 50% of the magnitude of the momentum before, and again the mass does not change, the velocity after the second rebound is half the velocity before the rebound, but of the opposite sign as the ball is now travelling in the opposite direction. So

$$u = \frac{1}{2}\sqrt{\frac{36 - x}{2}}$$

As the ball comes to rest when it returns to its starting point,

$$u = \frac{1}{2}\sqrt{\frac{36 - x}{2}}, v = 0, a = -1, s = 3.5 - x$$

Using $v^2 = u^2 + 2as$

$$0^2 = \left(\frac{1}{2}\sqrt{\frac{36 - x}{2}}\right)^2 + 2(-1)(3.5 - x)$$

$$0 = \frac{1}{4}\left(\frac{36 - x}{2}\right) - 7 + 2x$$

$$7 - 2x = \frac{36 - x}{8}$$

$$56 - 16x = 36 - x$$

$$20 = 15x$$

$$x = 1.\dot{3} = 1.33 \text{ m}$$

EXERCISE 7B

1 Total momentum before = $80 \times 3 = 240$

Total momentum after = $2(80 + m)$

$$240 = 2(80 + m)$$

$$240 = 160 + 2m$$

$$m = 40 \text{ kg}$$

2 Total momentum before = $0.04 \times 3 = 0.12$

Total momentum after = $0.06v$

$$0.12 = 0.06v$$

$$v = 2 \text{ m s}^{-1}$$

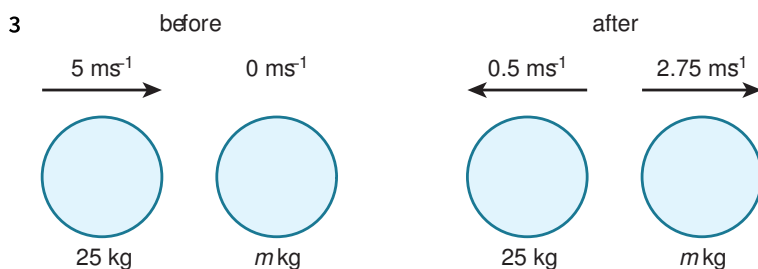

Total momentum before = $25 \times 5 = 125$

Total momentum after = $2.75m + 25(-0.5)$

$$125 = 2.75m - 12.5$$

$$m = 50 \text{ kg}$$

Note that as the ball has reversed its direction, the sign of its momentum has changed.

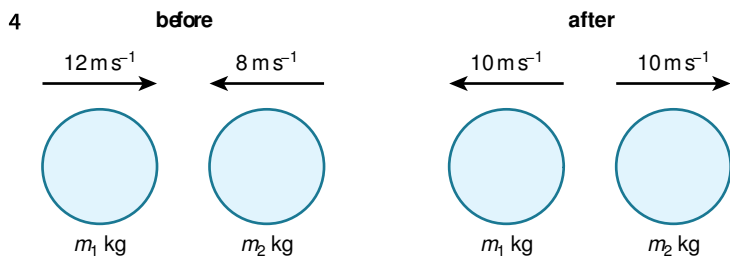

Let the mass of the first ball be m_1 and the mass of the second ball be m_2 .

Total momentum before = $12m_1 - 8m_2$

Total momentum after = $10m_2 - 10m_1$

$$12m_1 - 8m_2 = 10m_2 - 10m_1$$

$$22m_1 = 18m_2$$

$$11m_1 = 9m_2$$

The ratio of the masses of $m_1 : m_2$ is 9 : 11

Care is needed with the signs for the momentum of each ball. Make sure you are consistent with the direction you take as positive throughout the question.

5

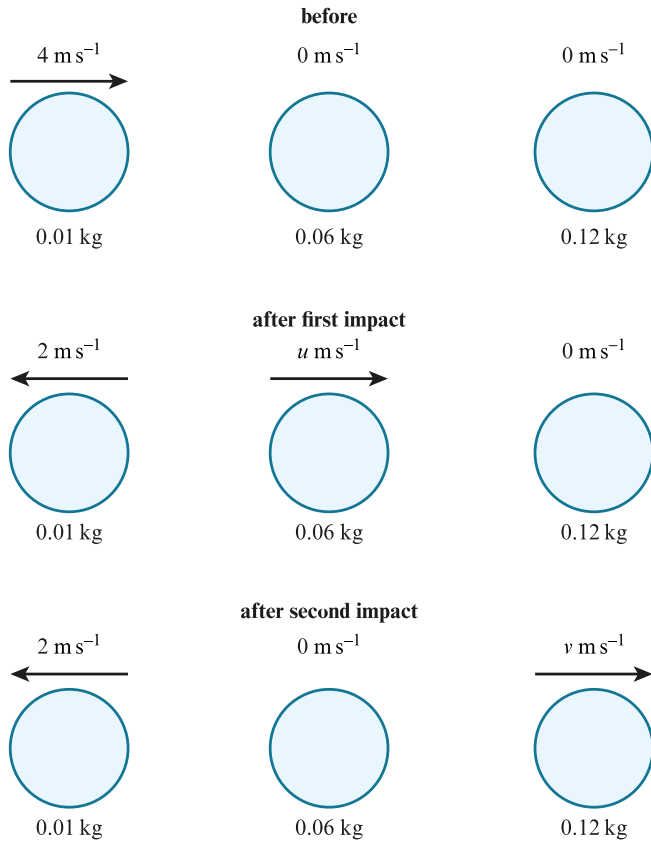

Total momentum before the first collision = $0.01 \times 4 = 0.04$

Let the velocity of particle *C* after the second collision be v .

Total momentum after the second collision = $0.12v + 0.01 \times (-2) = 0.12v - 0.02$

$$0.04 = 0.12v - 0.02$$

$$0.12v = 0.06$$

$$v = 0.5 \text{ m s}^{-1}$$

Alternatively, you could equate the momentum before and after the first collision to find the velocity of particle *B* after this collision. Then equate the momentum before and after the second collision to find the velocity of particle *C* after the second collision. This is an acceptable method, but it will take a bit longer to work out.

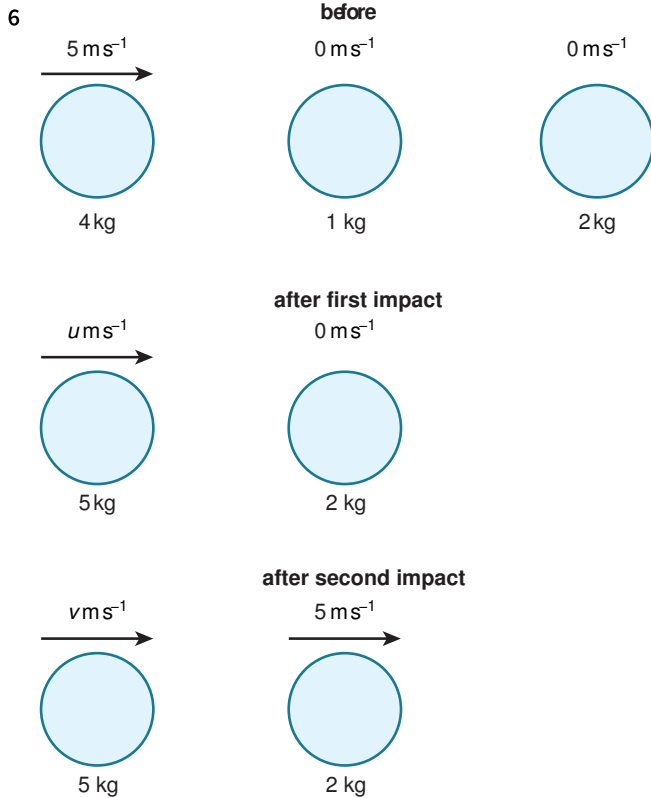

Total momentum before the first collision = $4 \times 5 = 20$

Let the velocity of particle *D* after the second collision be v .

Total momentum after the second collision = $2 \times 5 + 5v = 10 + 5v$

$$20 = 10 + 5v$$

$$5v = 10$$

$v = 2 \text{ m s}^{-1}$ in the same direction as *C*.

As velocity is asked for rather than speed, you should clearly state the direction.

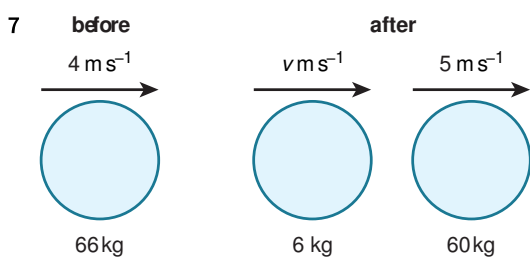

a Total momentum before = $66 \times 4 = 264$

Total momentum after = $6v + 60 \times 5 = 6v + 300$

$$264 = 6v + 300$$

$$6v = -36$$

$$v = -6$$

The velocity of the chair is 6 m s^{-1} in the opposite direction to Jayne.

b The motion is in a straight line. Jayne just stands and does not 'push off' with her skates. Jayne and the chair can be modelled as particles.

8 $100 \text{ g} = 0.1 \text{ kg}$

Total momentum before = $0.1 \times 5 = 0.5$

Total momentum after = $0.1(0.1 + m)$

$$0.5 = 0.1(0.1 + m)$$

$$0.5 = 0.01 + 0.1m$$

$$0.1m = 0.49$$

$$m = 4.9 \text{ kg}$$

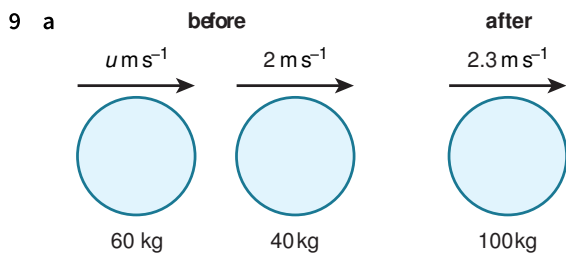

Let Sarah's speed just before she lands on the sledge be u .

$$\text{Total momentum before} = 60u + 40 \times 2 = 60u + 80$$

$$\text{Total momentum after} = (60 + 40) \times 2.3 = 230$$

$$60u + 80 = 230$$

$$60u = 150$$

$$u = 2.5 \text{ m s}^{-1}$$

b Sarah's velocity is horizontal.

10 a Let the speed of the shuttle immediately after the rocket boosters are detached be u .

$$\text{Total momentum before} = [60\,000 + 2(20\,000)] \times 1500 = 150\,000\,000$$

$$\text{Total momentum after} = 60\,000u$$

$$150\,000\,000 = 60\,000u$$

$$u = 2500 \text{ m s}^{-1} \text{ as required}$$

b Let the speed of the shuttle immediately after the first rocket booster is detached be v .

$$\text{Total momentum before} = [60\,000 + 2(20\,000) + 450\,000] \times 500 = 275\,000\,000$$

$$\text{Total momentum after} = (60\,000 + 20\,000 + 450\,000)v$$

$$275\,000\,000 = 530\,000v$$

$$v = 518.867 \dots = 518.9 \text{ m s}^{-1} \text{ as required}$$

c Let the speed of the shuttle just before the second rocket booster is detached be w .

$$\text{Total momentum before} = (60\,000 + 20\,000)w = 80\,000w$$

$$\text{Total momentum after} = 60\,000 \times 2500 = 150\,000\,000$$

$$80\,000w = 150\,000\,000$$

$$w = 1875 = 1880 \text{ m s}^{-1}$$

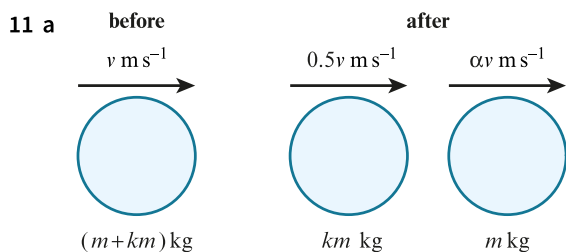

$$\text{Total momentum before} = v(km + m)$$

$$\text{Total momentum after} = 0.5vkm + \alpha vm$$

$$v(km + m) = 0.5vkm + \alpha vm$$

Cancel vm throughout

$$k + 1 = 0.5k + \alpha$$

$$0.5k + 1 = \alpha$$

$$\text{If } \alpha = 1.3$$

$$0.5k + 1 = 1.3$$

$$k = 0.6$$

as required

b From a $0.5k + 1 = \alpha$
 $0.5k = \alpha - 1$
 $k = 2(\alpha - 1)$

12 a

Before the collision, the particles could be travelling in the same direction or towards each other in opposite directions. After the collision, the particles could be travelling in the same direction or away from each other in opposite directions. This means there are four situations to consider. Each diagram looks at a different situation showing the direction of motion of each particle before and after impact.

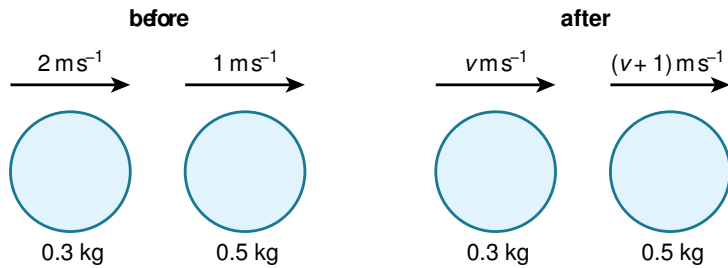

Total momentum before = $0.3 \times 2 + 0.5 \times 1 = 1.1$

Total momentum after = $0.3v + 0.5(v+1) = 0.8v + 0.5$

$0.8v + 0.5 = 1.1$

$0.8v = 0.6$

$v = 0.75 \text{ m s}^{-1}$

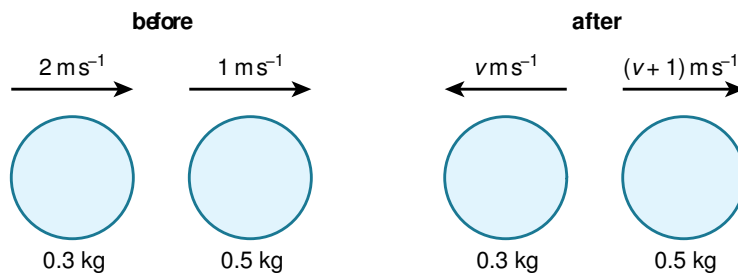

Total momentum before = $0.3 \times 2 + 0.5 \times 1 = 1.1$

Total momentum after = $-0.3v + 0.5(v+1) = 0.2v + 0.5$

$0.2v + 0.5 = 1.1$

$0.2v = 0.6$

$v = 3 \text{ m s}^{-1}$

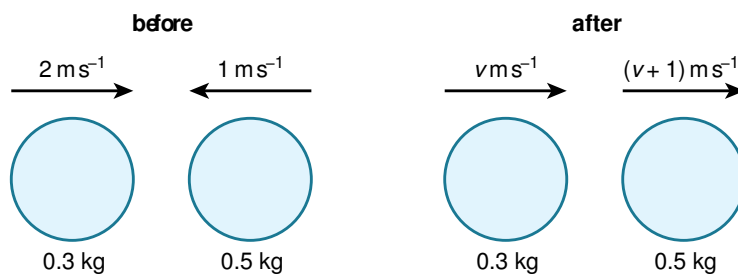

Total momentum before = $0.3 \times 2 + 0.5 \times (-1) = 0.1$

Total momentum after = $0.3v + 0.5(v+1) = 0.8v + 0.5$

$0.8v + 0.5 = 0.1$

$0.8v = -0.4$

$v = -0.5 \text{ m s}^{-1}$

Meaning the first particle moves with speed 0.5 m s^{-1}

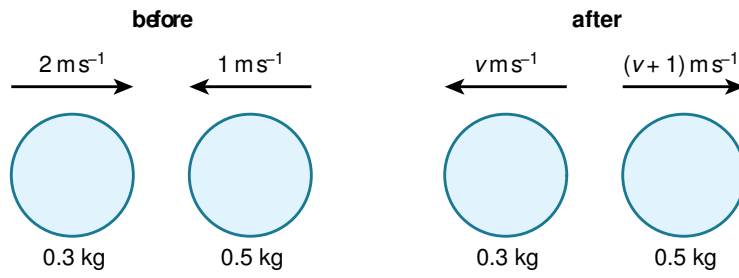

Total momentum before = $0.3 \times 2 + 0.5 \times (-1) = 0.1$

Total momentum after = $-0.3v + 0.5(v + 1) = 0.2v + 0.5$

$0.2v + 0.5 = 0.1$

$0.2v = -0.4$

$v = -2 \text{ m s}^{-1}$

Meaning the smaller particle moves with speed 2 m s^{-1}

- b** The smallest of these possible speeds is 0.5 m s^{-1} and this occurs in the third scenario in part **a** when the particles are travelling in opposite directions before impact.

END-OF-CHAPTER REVIEW EXERCISE 7

1 Total momentum before = $4 \times 3 = 12$

Total momentum after = $6u$

$$12 = 6u$$

$$u = 2$$

As the speed is stated as $u \text{ m s}^{-1}$, the value of u is 2 rather than 2 m s^{-1}

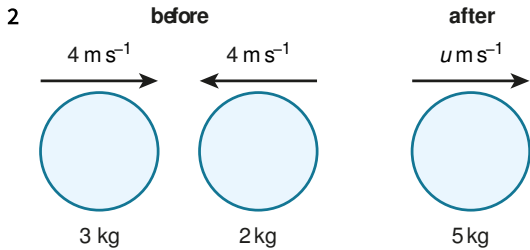

Let the speed of the combined particle be u

Total momentum before = $3 \times 4 - 2 \times 4 = 4$

Total momentum after = $5u$

$$4 = 5u$$

$$u = 0.8 \text{ m s}^{-1}$$

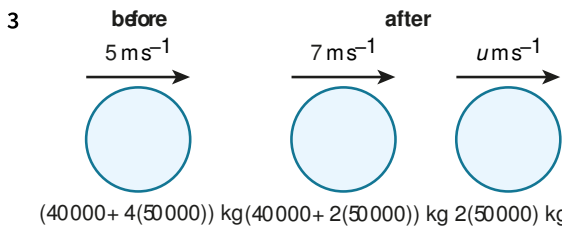

Let the speed of the two rear coaches be u

Total momentum before = $[40\,000 + 4(50\,000)] \times 5 = 1\,200\,000$

Total momentum after = $[40\,000 + 2(50\,000)] \times 7 + 2(50\,000)u = 980\,000 + 100\,000u$

$$1\,200\,000 = 980\,000 + 100\,000u$$

$$100\,000u = 220\,000$$

$$u = 2.2 \text{ m s}^{-1}$$

$$u = 2.2, v = 0, s = 100$$

Using $s = \frac{1}{2}(u + v)t$

$$100 = \frac{1}{2}(2.2 + 0)t$$

$$100 = 1.1t$$

$$t = 90.9 \dot{0} = 90.9 \text{ s}$$

Find the velocity of the two rear coaches using conservation of momentum then use equations of constant acceleration to find the time to come to rest.

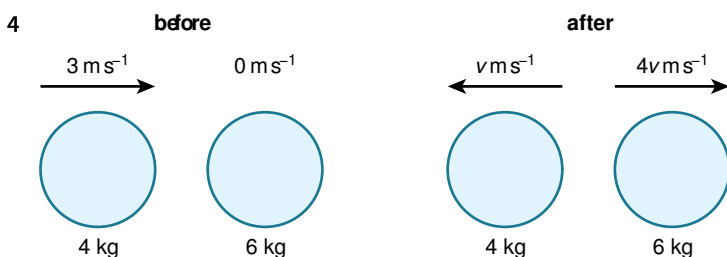

Total momentum before = $4 \times 3 = 12$

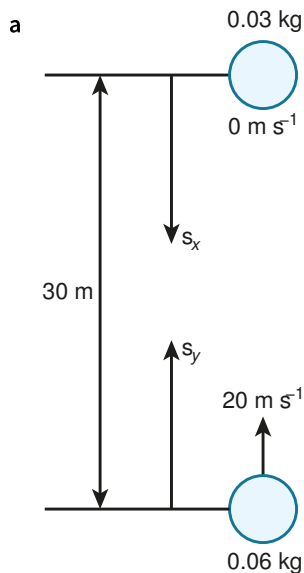

For ball *X*, taking downwards as positive, and measuring s_x from the window level where *X* is released, 30 m above the floor:

$$u = 0, a = 10, s = s_x, t = t$$

$$\text{Using } s = ut + \frac{1}{2}at^2$$

$$s_x = 0(t) + \frac{1}{2}(10)t^2 = 5t^2 \dots\dots\dots [1]$$

For ball *Y*, taking upwards as positive, and measuring s_y from ground level:

$$u = 20, a = -10, s = s_y, t = t$$

$$\text{Using } s = ut + \frac{1}{2}at^2$$

$$s_y = 20t + \frac{1}{2}(-10)t^2 = 20t - 5t^2 \dots\dots [2]$$

The balls meet when $s_x + s_y = 30$

$$5t^2 + 20t - 5t^2 = 30$$

$$20t = 30$$

$$t = 1.5 \text{ s}$$

$$v_X = 0 + 10(1.5) = 15 \text{ m s}^{-1}$$

Momentum of *X* is $0.03 \times 15 = 0.45 \text{ Ns}$

$$v_Y = -20 + 10(1.5) = -5 \text{ m s}^{-1}$$

Momentum of *Y* is $0.01 \times -5 = -0.05 \text{ Ns}$

b Height when particles meet is s_Y when $t = 1.5$

$$\text{Using [2], } s_Y = 20 \times 1.5 - 5 \times 1.5^2 = 18.75$$

Let the speed of the combined object be u

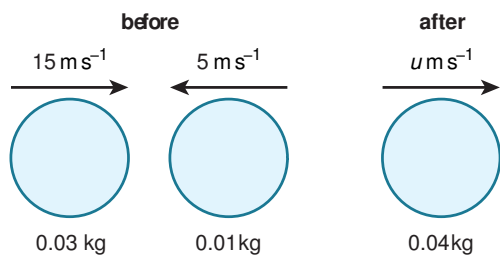

From part **a** the total momentum before = $0.45 - 0.05 = 0.4$

Total momentum after = $(0.03 + 0.01)u$

$$(0.03 + 0.01)u = 0.4$$

$$0.04u = 0.4$$

$$u = 10 \text{ m s}^{-1}$$

Find time for combined object to reach ground:

$$u = 10, a = 10, s = 18.75$$

$$\text{Using } s = ut + \frac{1}{2}at^2$$

$$18.75 = 10t + \frac{1}{2}(10)t^2$$

$$5t^2 + 10t - 18.75 = 0$$

$$t = \frac{-10 \pm \sqrt{10^2 - 4(5)(-18.75)}}{2(5)} = \frac{-10 \pm \sqrt{475}}{2(5)} = 1.179 \dots \text{ s}$$

$$\text{Total time from when } X \text{ starts to fall} = 1.5 + 1.179 \dots = 2.6794 \dots = 2.68 \text{ s}$$

9

Consider the velocity of B after each collision, and the constraints on each of these velocities.

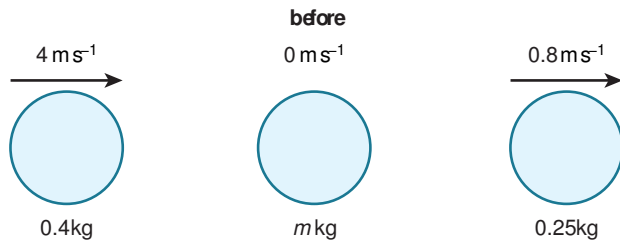

Let the speed of B after the first collision be u

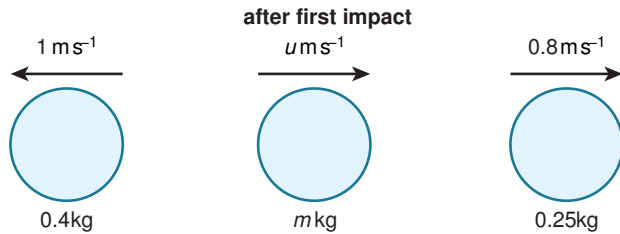

$$\text{Total momentum before} = 0.4 \times 4 + 0.8 \times 0.25 = 1.8$$

$$\text{Total momentum after} = 0.4 \times (-1) + mu + 0.25 \times 0.8 = mu - 0.2$$

$$1.8 = mu - 0.2$$

$$mu = 2$$

As B catches up with and collides with C , we know that $u > 0.8$

$$\text{So as } mu = 2, m < \frac{2}{0.8} \text{ or } m < 2.5$$

After the second collision, B could be moving in the positive or negative direction so you should consider both possibilities.

Let the speed of B after the second collision be v .

If B moves in the positive direction:

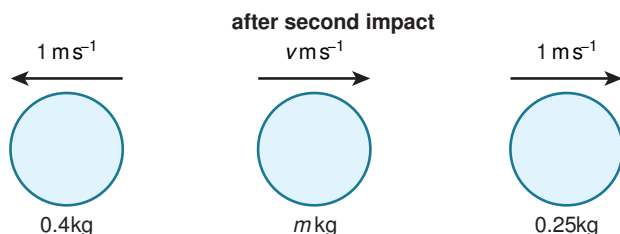

$$\text{Total momentum before any impact is still } 0.4 \times 4 + 0.8 \times 0.25 = 1.8$$

$$\text{Total momentum after second collision} = 0.4 \times (-1) + mv + 0.25 \times 1 = mv - 0.15$$

$$mv - 0.15 = 1.8$$

$$mv = 1.95$$

As there are no more collisions, $v < 1$

$$\text{So as } mv = 1.95, m > \frac{1.95}{1} \text{ or } m > 1.95$$

If B moves in the negative direction:

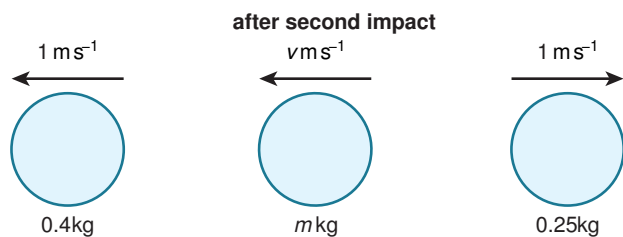

Total momentum after both collisions = $0.4 \times (-1) - mv + 0.25 \times 1 = -mv - 0.15$

$$-mv - 0.15 = 1.8$$

$$mv = -1.95$$

As there are no more collisions, $v > -1$

So as $mv = -1.95$, $m > \frac{1.95}{1}$ or $m > 1.95$ as before

So $1.95 < m < 2.5$

10 a $u = 0$, $a = 10$, $s = 1.8$

$$v^2 = u^2 + 2as$$

$$v^2 = 0^2 + 2(10)(1.8) = 36$$

$$v = 6 \text{ m s}^{-1}$$

Momentum just before the bounce = $mv = 0.6(6) = 3.6 \text{ Ns}$

10% of the speed is lost after the bounce, so new speed = $6 \times 0.9 = 5.4$, but new velocity = -5.4 m s^{-1}

Momentum just after the bounce = $mv = 0.6(-5.4) = -3.24 \text{ Ns}$

Amount of momentum absorbed by the floor = decrease in momentum of the ball = $3.6 - (-3.24) = 6.84 \text{ Ns}$

Use equations of constant acceleration to find the speed of the ball just before the bounce, so the loss of momentum can then be found.

b Taking downwards as positive

After the first bounce, the height reached is found from

$$u = -5.4, v = 0, a = 10$$

$$v^2 = u^2 + 2as$$

$$0^2 = (-5.4)^2 + 2(10)s$$

$$s = -\frac{29.16}{20} = -1.458$$

A height of 1.46 m is reached

Just before the second bounce $v = 5.4$

Just after the second bounce $v = 0.9 \times -5.4 = -4.86$

After the second bounce, the height reached is found from

$$u = -4.86, v = 0, a = 10$$

$$v^2 = u^2 + 2as$$

$$0^2 = (-4.86)^2 + 2(10)s$$

$$s = -\frac{23.6196}{20} = -1.18098$$

A height of 1.18 m is reached.

Just before the third bounce $v = 4.86$

Just after the third bounce $v = 0.9 \times -4.86 = -4.374$

After the third bounce, the height reached is found from

$$u = -4.374, v = 0, a = 10$$

$$v^2 = u^2 + 2as$$

$$0^2 = (-4.374)^2 + 2(10)s$$

$$s = -\frac{19.131876}{20} = -0.95658 \dots$$

So the ball fails to reach a height of 1 m after the third bounce, as required.

c The ball can be modelled as a particle, so the ball has no size, and there is no air resistance.

11 a

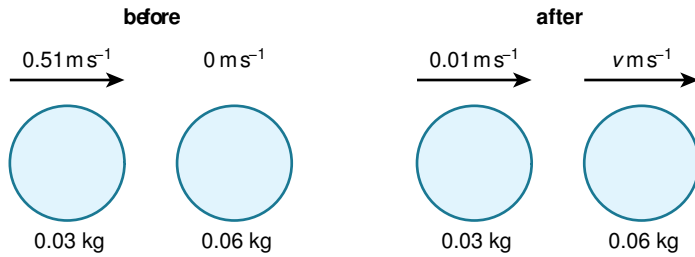

$$30 \text{ g} = 0.03 \text{ kg}$$

$$60 \text{ g} = 0.06 \text{ kg}$$

Let the speed of Y after the first collision be v

$$\text{Total momentum before the first collision} = 0.03 \times 0.51 = 0.0153$$

$$\text{Total momentum after the first collision} = 0.03 \times 0.01 + 0.06v = 0.0003 + 0.06v$$

$$0.0153 = 0.0003 + 0.06v$$

$$0.06v = 0.015$$

$$v = 0.25 \text{ m s}^{-1}$$

So the velocity of Y after the collision with the wall is -0.125 m s^{-1}

$$\text{Amount of momentum absorbed by the wall is } 0.06 [0.25 - (-0.125)] = 0.0225 \text{ N s}$$

b Let the original direction of travel for X be the positive direction.

$$\text{Total momentum before impact} = 0.03 \times 0.01 + 0.06 \times -0.125 = -0.0072 \text{ N s.}$$

This is negative so at least one ball must be travelling in the negative direction after impact.

Y cannot pass through X, so X must reverse its direction of travel.

c Let the speed of Y after the final collision be v

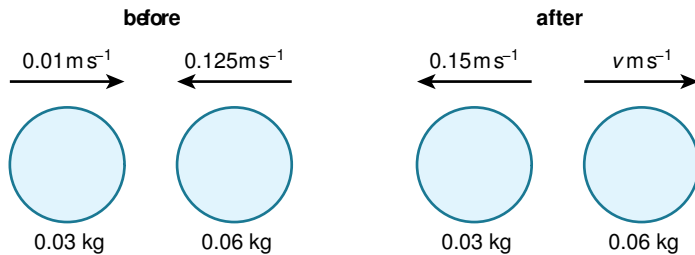

$$\text{Total momentum before the final collision} = 0.03 \times 0.01 + 0.06 \times (-0.125) = -0.0072$$

$$\text{Total momentum after the final collision} = 0.03 \times (-0.15) + 0.06v = -0.0045 + 0.06v$$

$$-0.0072 = -0.0045 + 0.06v$$

$$0.06v = -0.0027$$

$$v = -0.045 \text{ m s}^{-1}$$

12 Let the speed of X after the first collision be v , then the speed of ball Y is $3v$.

Both X and Y must be travelling towards Z because Y next collides with Z and then collides again with X while travelling at the same speed as X.

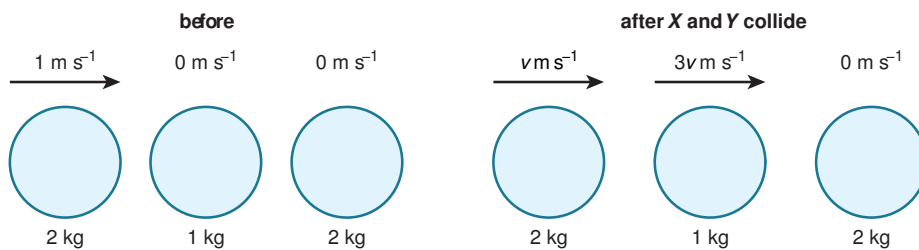

$$\text{Total momentum before the first collision} = 2 \times 1 = 2$$

$$\text{Total momentum after the first collision} = 2v + 1 \times 3v = 5v$$

$$2 = 5v$$

$$v = 0.4$$

So X has velocity 0.4

Y has velocity $3 \times 4 = 1.2$ (positive as it goes on to collide with Z)

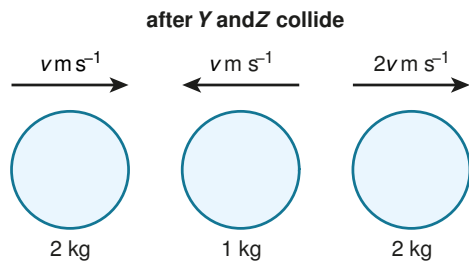

After Y collides with Z

Y has velocity -0.4 (negative as it goes on to collide with X and as both have the same speed, they must be travelling towards each other in order to collide)

Z has velocity $2 \times 0.4 = 0.8$ (positive as Z cannot pass through Y and is travelling faster than Y)

After Y collides with X for a second time

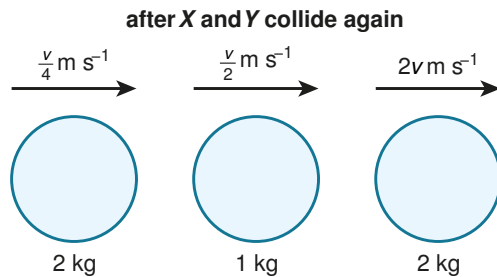

Y has velocity $\frac{0.8}{4} = 0.2$ (positive as Y is travelling faster than X and cannot pass through X)

Speed of X = $\frac{0.2}{2} = 0.1$

To find the direction of X, find the total momentum.

From previous work, total momentum before the first collision = $2 \times 1 = 2$

If X travels in negative direction, total final momentum = $2 \times (-0.1) + 1 \times 0.2 + 2 \times 0.8 = 1.6$

If X travels in positive direction, total final momentum = $2 \times (0.1) + 1 \times 0.2 + 2 \times 0.8 = 2$

Momentum is conserved, and so X must travel in positive direction and have velocity 0.1

So all balls are travelling in the same direction.

Speed of X (0.1 m s^{-1}) < speed of Y (0.2 m s^{-1}) < speed of Z (0.8 m s^{-1})

No further collisions can occur, as all balls are travelling in the same direction and X cannot catch up with Y which in turn cannot catch up with Z.

Chapter 8

Work and energy

EXERCISE 8A

1 Work done = $Fd = 30 \times 2 = 60 \text{ J}$

Remember to give units.

2 a Work done = $Fd = 20 \times 5 = 100 \text{ J}$

b Work done = $Fd \cos \theta = 20 \times 5 \cos 40 = 76.604 \dots = 76.6 \text{ J}$

You can think of this as $20 \text{ N} \times 5 \cos 40 \text{ m}$ or $20 \cos 40 \text{ N} \times 5 \text{ m}$

3 a Work done = $Fd = 0.4 \times (-2) = -0.8 \text{ J}$

When the ball rises, the work done by gravity is -0.8 J or the work done against gravity is $+0.8 \text{ J}$.

b Work done = $Fd = 0.4 \times 2 = 0.8 \text{ J}$

c Work done = $Fd = 0.4 \times 0 = 0 \text{ J}$

The ball is at the same level at the end of the motion as at the beginning, so the difference in height is zero.

4 Work done = $Fd = 600 \times 10 - 600 \times 6 = 2400 \text{ J}$

Alternatively, the difference in height is $10 - 6 = 4 \text{ m}$ so the work done = $Fd = 600 \times 4 = 2400 \text{ J}$.

5 a Friction from the edge of the canal, resistance from the water and some air resistance.

b Work done = $Fd = 100 \times 20 = 2000 \text{ J}$

6 a i Work done = $Fd \cos \theta = 150 \times 40 \cos 10 = 5908.84 \dots = 5910 \text{ J}$

ii Work done = $Fd \cos \theta = 150 \times 40 \cos 20 = 5638.155 \dots = 5640 \text{ J}$

b Work done = $Fd \cos \theta = T \times 40 \cos 20 = 5908.84 \dots$

$T = 157.20 \dots = 157.2 \text{ N}$ as required

c The component of the tension perpendicular to the direction of motion is more than double in the second situation ($157.2 \cos 70 = 53.8 \text{ N}$) compared with the first ($150 \cos 80 = 26.0 \text{ N}$) so the frictional resistance will be greater.

7 a Work done against friction = $Fd = 3 \times 2 = 6 \text{ J}$

b Work done by the tension = $Fd \cos \theta = 10 \times 2 \cos 30 = 17.320 \dots = 17.3 \text{ J}$

c Work done by the weight = $Fd = 10 \text{ m} \times 0 = 0 \text{ J}$

As no motion occurs in the direction in which the weight acts, there is zero work done by the weight.

d Work done by the normal contact force = $Fd = (10 \text{ m} - 10 \sin 30) \times 0 = 0 \text{ J}$

Similarly to part c, as no motion occurs in the direction in which the normal contact force acts, there is zero work done by the normal contact force.

e Total work done = $17.320 \dots - 6 = 11.320 \dots = 11.3 \text{ J}$

Total work done = work done by tension – work done against friction is positive, which represents the work done in moving the box.

8

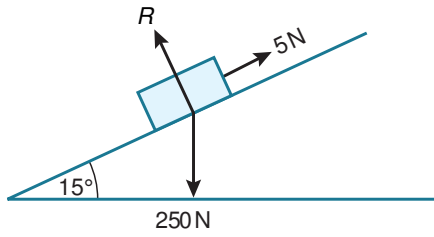

a Work done against non-gravitational resistance = $Fd = 5 \times 4 = 20 \text{ J}$

b Work done by gravity = $Fd = 250 \times 4 \sin 15 = 258.81 \dots = 259 \text{ J}$

So, work done against gravity = -259 J

Work done against gravity is negative because the object is moving downwards.

c Work done by the normal contact force = $Fd = 250 \cos 15 \times 0 = 0 \text{ J}$

d Total work done = $258.81 \dots - 20 = 238.81 \dots = 239 \text{ J}$

Total work done by all the forces is:

work done by gravity – work done against non-gravitational resistance

9

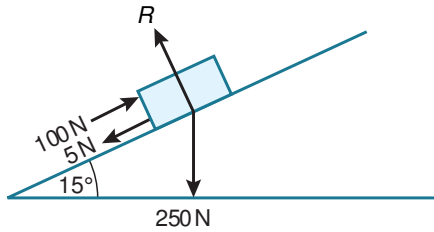

a Work done by the force of $100 \text{ N} = Fd = 100 \times 4 = 400 \text{ J}$

b Work done against non-gravitational resistance = $Fd = 5 \times 4 = 20 \text{ J}$

c Work done against gravity = $Fd = 250 \times 4 \sin 15 = 258.81 \dots = 259 \text{ J}$

d Work done by the normal contact force = $Fd = 250 \times 0 = 0 \text{ J}$

e Total work done = $400 - 20 - 258.81 \dots = 121.18 \dots = 121 \text{ J}$

10

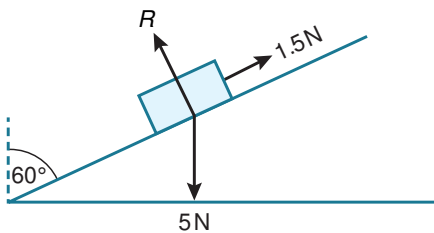

a Work done by gravity = $Fd = 5 \times 2 \cos 60 = 5 \text{ J}$

b Work done against friction = $Fd = 1.5 \times 2 = 3 \text{ J}$

c Work done by the normal contact force = $Fd = 5 \sin 60 \times 0 = 0 \text{ J}$

d Total work done = $5 - 3 = 2 \text{ J}$

11 Work done = work done by tension – work done against frictional resistance

= $25 \times 12 \cos 10 - 1 \times 12 + 20 \times 0 = 283.44 \dots = 283 \text{ J}$

As the work done by normal contact force is zero, there is no need to include it in the calculation for the total

12

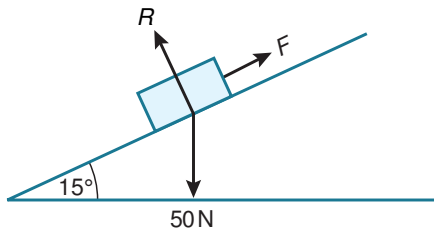

To find the work done against friction, first find the frictional force.

Newton's second law (perpendicular to the plane)

$$R - 50 \cos 15 = 0 \text{ so } R = 50 \cos 15$$

$$F = \mu R = 0.25 \times 50 \cos 15 = 12.5 \cos 15$$

Work done = work done by weight - work done against friction

$$= 50 \sin 15 \times 2 - 12.5 \cos 15 \times 2$$

$$= 1.733 \dots = 1.73 \text{ J}$$

EXERCISE 8B

1 $KE = \frac{1}{2}mv^2 = \frac{1}{2}(10)(8^2) = 320 \text{ J}$

2 $KE = \frac{1}{2}mv^2 = \frac{1}{2}(1500)(22^2) = 363\,000 \text{ J}$ or 363 kJ

3 $57 \text{ g} = 0.057 \text{ kg}$

$$180 \text{ kmh}^{-1} = \frac{180 \times 1000}{60 \times 60} = 50 \text{ m s}^{-1}$$

$$KE = \frac{1}{2}mv^2 = \frac{1}{2}(0.057)(50^2) = 71.25 = 71.3 \text{ J}$$

4 KE before = $\frac{1}{2}(4)(3^2) = 18$

$$KE \text{ after} = \frac{1}{2}(4)(6^2) = 72$$

$$\text{Increase in KE} = 72 - 18 = 54 \text{ J}$$

5 a $a = 10, u = 0, s = 10.8$

$$\text{Using } v^2 = u^2 + 2as$$

$$v^2 = 0^2 + 2(10)(10.8) = 216$$

$$v = \pm 14.696\dots$$

$$\text{So the speed is } 14.7 \text{ m s}^{-1}$$

b KE before = 0 as the book falls from rest

$$KE \text{ after} = \frac{1}{2}mv^2 = \frac{1}{2}(2)(216) = 216$$

$$\text{Increase in KE} = 216 - 0 = 216 \text{ J}$$

Use $v^2 = 216$ from part **a** rather than $v = 14.7$ to avoid rounding errors.

6 a $u = 3, s = 40, t = 5$

$$\text{Using } s = \frac{1}{2}(u + v)t$$

$$40 = \frac{1}{2}(3 + v)(5)$$

$$16 = 3 + v$$

$$v = 13 \text{ m s}^{-1}$$

b KE before = $\frac{1}{2}(1)(3^2) = 4.5$

$$KE \text{ after} = \frac{1}{2}(1)(13^2) = 84.5$$

$$\text{Increase in KE} = 84.5 - 4.5 = 80 \text{ J}$$

Note the increase in KE can also be calculated as $\frac{1}{2} \times 1 \times (13^2 - 3^2)$ but not as $\frac{1}{2} \times 1 \times (13 - 3)^2$.

7 Initial KE = 0.735 J

$$\text{Final KE} = 0 \text{ as ball bearing is at rest}$$

$$\text{Loss in KE} = 0.735 = \frac{1}{2}mv^2 = \frac{1}{2}(0.03)v^2$$

$$0.015v^2 = 0.735$$

$$v^2 = 49$$

$$v = \pm 7 \text{ so the speed is } 7 \text{ m s}^{-1}$$

8 Increase in KE = 375 J

Box starts from rest, so initial KE is 0 and final KE is 375 J

$$\frac{1}{2}mv^2 = \frac{1}{2}(30)v^2 = 375$$

$$v^2 = 25$$

$v = \pm 5$ so the speed of the box at the bottom of the slope is 5 m s^{-1}

To find the box's acceleration use Newton's second law (parallel to and down the slope)

$$30 \sin 30 = 3a$$

$$a = 10 \sin 30 \text{ m s}^{-2}$$

$$a = 10 \sin 30, u = 0, v = 5$$

Using $v^2 = u^2 + 2as$

$$5^2 = 0^2 + 2(10 \sin 30)s$$

$$10s = 25$$

$$s = 2.5 \text{ m}$$

Find the speed of the box at the bottom of the slope, then use equations of constant acceleration to find the length of the slope.

- 9 a Constant speed, so acceleration is zero. Speed = distance \div time = $100 \div 16 = 6.25 \text{ m s}^{-1}$

$$\text{KE} = \frac{1}{2}mv^2 = \frac{1}{2}(64)(6.25^2) = 1250 \text{ J}$$

- b There will be no difference if the track was curved, provided the speed is still constant.

- 10 a 2 million = 2 000 000 kg

Increase in KE = final KE - initial KE

Initial KE = 0 as rocket is at rest

$$\text{So increase in KE} = \text{final KE} = \frac{1}{2}mv^2$$

$$= \frac{1}{2}(2\,000\,000)(75\,000^2) = 5.625 \times 10^{15} = 5.63 \times 10^{15} \text{ J}$$

- b The calculated value will be too high because fuel will be used while the rocket is accelerating, so the mass will decrease, meaning the KE will decrease.

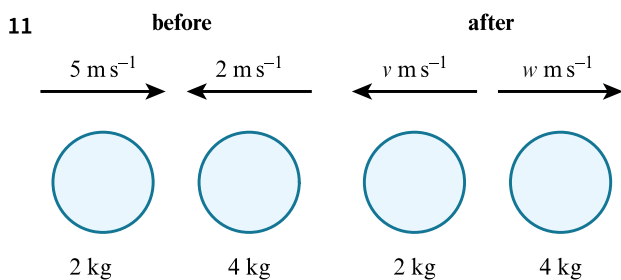

- a Let the speed of ball A after the impact be v and let the speed of ball B after the impact be w .

Use conservation of momentum to find an equation connecting v and w .

$$\text{Total momentum before} = 2 \times 5 - 4 \times 2 = 2$$

$$\text{Total momentum after} = 4w + 2(-v) = 4w - 2v$$

$$4w - 2v = 2$$

$$2w - v = 1$$

$$w = \frac{1+v}{2} \dots\dots\dots [1]$$

$$\text{KE before} = \frac{1}{2}(2)(5^2) + \frac{1}{2}(4)(2^2) = 33$$

$$\text{KE after} = \frac{1}{2}(2)(v^2) + \frac{1}{2}(4)(w^2) = v^2 + 2w^2$$

Although the velocity of ball B is negative, when finding its KE you are squaring the velocity so you can use $(-v)^2$ or v^2 .

$$\text{KE lost} = \text{KE before} - \text{KE after} = 33 - (v^2 + 2w^2) = 12.5 \dots\dots\dots [2]$$

Substitute [1] into [2]

$$33 - v^2 - 2\left(\frac{1+v}{2}\right)^2 = 12.5$$

$$33 - v^2 - 2\left(\frac{1+2v+v^2}{4}\right) = 12.5$$

$$33 - v^2 - 0.5 - v - 0.5v^2 = 12.5$$

$$1.5v^2 + v - 20 = 0$$

Using $\frac{-b \pm \sqrt{b^2 - 4ac}}{2a}$

$$v = \frac{-1 \pm \sqrt{1^2 - 4(1.5)(-20)}}{2(1.5)} = \frac{-1 \pm 11}{3}$$

$v > 0$, as each ball reverses its direction of travel after the impact, so $v = \frac{10}{3} \text{ m s}^{-1}$ as required

The question asks for the speed of ball A after the impact but you may find it simpler to write $v = 2w + 1$ for equation [1] and substitute to find the speed of ball B first and then work out the speed of ball A .

b The speed of ball B after impact is $w = \frac{1+v}{2}$ from [1]

$$w = \frac{1 + \left(\frac{10}{3}\right)}{2} = \frac{13}{3} \div 2 = \frac{13}{6} = 2.1\dot{6} = 2.17 \text{ m s}^{-1}$$

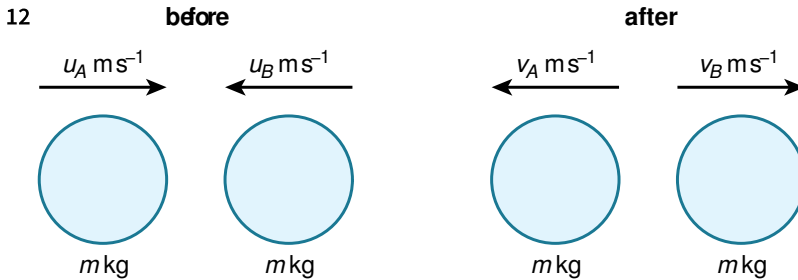

Let the mass of both balls be m .

$$\text{Total momentum before} = mu_A + m(-u_B) = mu_A - mu_B$$

$$\text{Total momentum after} = mv_B + m(-v_A) = mv_B - mv_A$$

$$\text{So } mu_A - mu_B = mv_B - mv_A$$

$$u_A - u_B = v_B - v_A$$

$$u_A + v_A = v_B + u_B \dots\dots\dots [1]$$

$$\text{KE before} = \frac{1}{2}mu_A^2 + \frac{1}{2}mu_B^2$$

$$\text{KE after} = \frac{1}{2}mv_A^2 + \frac{1}{2}mv_B^2$$

KE is conserved, so KE before = KE after

$$\frac{1}{2}mu_A^2 + \frac{1}{2}mu_B^2 = \frac{1}{2}mv_A^2 + \frac{1}{2}mv_B^2$$

$$u_A^2 + u_B^2 = v_A^2 + v_B^2$$

$$u_A^2 - v_A^2 = v_B^2 - u_B^2$$

$$(u_A + v_A)(u_A - v_A) = (v_B + u_B)(v_B - u_B)$$

Substitute in [1]

$$(v_B + u_B)(u_A - v_A) = (v_B + u_B)(v_B - u_B) \dots\dots\dots [2]$$

$$\text{So } u_A - v_A = v_B - u_B$$

Add equation [1]

$$2u_A = 2v_B$$

So $u_A = v_B$

and then from [2] $u_A - v_A = v_B - u_B$ and as $u_A = v_B$ this means $-v_A = -u_B$ or $v_A = u_B$ as required.

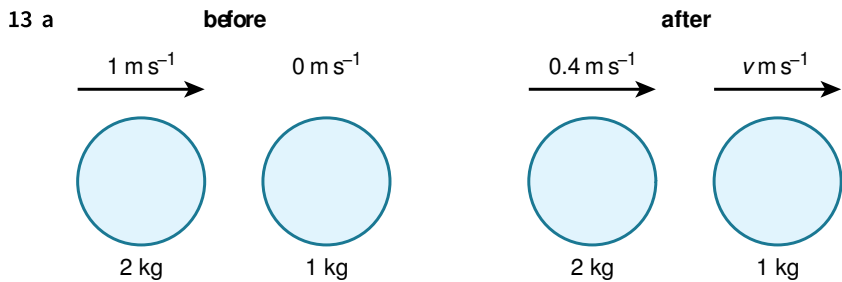

As ball X travels in its original direction after the first collision, ball Y must also travel in this direction as it cannot pass through ball X .

Let the speed of ball Y after the impact be v .

Total momentum before = $2 \times 1 = 2$

Total momentum after = $2 \times 0.4 + 1v = 0.8 + v$

$$0.8 + v = 2$$

$$v = 1.2 \text{ m s}^{-1}$$

$$\text{KE before} = \frac{1}{2}(2)(1^2) = 1$$

$$\text{KE after} = \frac{1}{2}(2)(0.4^2) + \frac{1}{2}(1)(1.2^2) = 0.88$$

$$\text{Loss of KE} = \text{KE before} - \text{KE after} = 1 - 0.88 = 0.12 \text{ J}$$

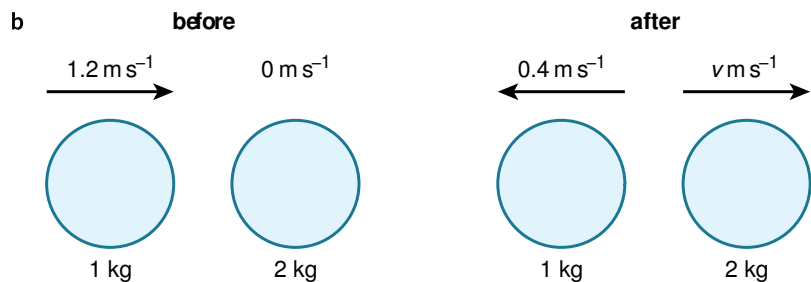

Consider just balls Y and Z , and let the speed of ball Z after the impact be v .

Total momentum before = $1 \times 1.2 = 1.2$

Total momentum after = $2v + 1 \times (-0.4) = 2v - 0.4$

$$2v - 0.4 = 1.2$$

$$v = 0.8 \text{ m s}^{-1}$$

$$\text{KE before} = \frac{1}{2}(1)(1.2^2) = 0.72$$

$$\text{KE after} = \frac{1}{2}(1)(0.4^2) + \frac{1}{2}(2)(0.8^2) = 0.72$$

$$\text{Loss of KE} = \text{KE before} - \text{KE after} = 0.72 - 0.72 = 0 \text{ J}$$

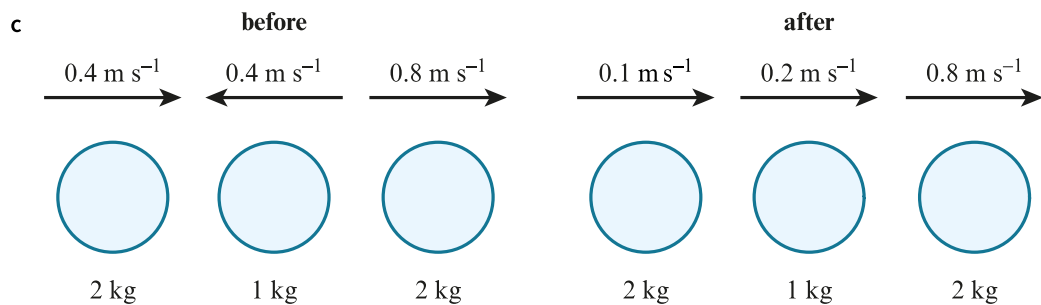

Now consider all three particles before and after the third impact

Particle X has velocity 0.4 m s^{-1} before the impact (stated in the stem of the question) and 0.1 m s^{-1} after the

impact (the speed of Z is 0.8 m s^{-1} as found in part **b**, so the speed of Y is 0.2 m s^{-1} as it is a quarter of the speed of Z and the speed of X is 0.1 m s^{-1} as it is half the speed of Y).

Particle Y has velocity -0.4 m s^{-1} before the impact (stated in the question before part **b**) and its speed after the impact is 0.2 m s^{-1} as it is a quarter of the speed of Z .

As particle Z is not involved in the third impact, its velocity is 0.8 m s^{-1} both before and after this impact.

$$\text{KE before} = \frac{1}{2}(2)(0.4^2) + \frac{1}{2}(1)(0.4^2) + \frac{1}{2}(2)(0.8^2) = 0.88$$

$$\text{KE after} = \frac{1}{2}(2)(0.1^2) + \frac{1}{2}(1)(0.2^2) + \frac{1}{2}(2)(0.8^2) = 0.67$$

$$\text{Loss of KE} = \text{KE before} - \text{KE after} = 0.88 - 0.67 = 0.21 \text{ J}$$

The KE for the particle Z has been included in the calculations, but it could have been excluded as it does not change before and after the third impact.

EXERCISE 8C

- 1 Increase in PE = $mgh = 5 \times 10 \times 2 = 100 \text{ J}$
- 2 As the body has fallen, the PE change is a decrease.
Decrease in PE = $mgh = 10 \times 10 \times 6 = 600 \text{ J}$
- 3 $57 \text{ g} = 0.057 \text{ kg}$
 $70 \text{ cm} = 0.7 \text{ m}$
Increase in PE = $mgh = 0.057 \times 10 \times 0.7 = 0.399 \text{ J}$
- 4 a Loss in PE = $mgh = 25 \times 10 \times 2 = 500 \text{ J}$
- b Work done by gravity = loss in PE = 500 J
- c $a = 10, u = 0, s = 2$
Using $v^2 = u^2 + 2as$
 $v^2 = 0^2 + 2(10)(2) = 40$

As you are finding the increase in KE, only v^2 is needed, not v .

$$\text{Gain in KE} = \frac{1}{2}(25)(40) = 500 \text{ J}$$

Notice this answer is the same as the loss in PE found in part b.

- 5 Decrease in PE = $mgh = 1.2 \times 10 \times 3 \sin 35 = 20.648 \dots = 20.6 \text{ J}$

Remember h is the vertical distance fallen and not the distance travelled down the slope.

- 6 $18 \text{ cm} = 0.18 \text{ m}$
Height climbed = flights \times stairs in each flight \times depth of each stair = $3 \times 15 \times 0.18 = 8.1 \text{ m}$
Increase in PE = $mgh = 70 \times 10 \times 8.1 = 5670 \text{ J}$
- 7 Let the mass of the crate be m .
Using work done = Fd , distance moved by the crate up the slope = $75 \div 50 = 1.5 \text{ m}$
Increase in PE = $168 = mgh = m \times 10 \times 1.5 \sin \theta = 15 \times 0.28 m$
 $168 = 4.2 m$
 $m = 40 \text{ kg}$

- 8 a

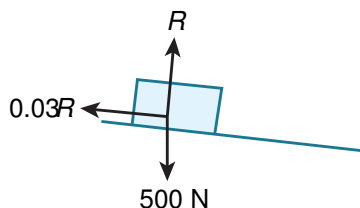

- b Let the length of the ramp be s .

As the ramp raises 10 cm for every 80 cm along the sloping surface, $\sin \theta = \frac{10}{80} = 0.125$

$$\text{so } \cos \theta = \sqrt{1 - 0.125^2} = \sqrt{0.984375}$$

Remember

$$\sin^2 \theta + \cos^2 \theta = 1$$

$$\text{So } \cos^2 \theta = 1 - \sin^2 \theta$$

$$\text{and } \cos \theta = \sqrt{1 - \sin^2 \theta}$$

Using Newton's second law perpendicular to the slope

$$R - 500 \cos \theta = 0$$

$$R = 500 \cos \theta$$

$$\text{But } F = \mu R = 0.03(500 \cos \theta)$$

Newton's second law (parallel to and down the slope)

$$500 \sin \theta - F = 50 a$$

$$500 \sin \theta - 0.03(500 \cos \theta) = 50 a$$

$$47.6176 \dots = 50 a$$

$$a = 0.9523 \dots = 0.952 \text{ m s}^{-2}$$

As the box starts from rest, when the box reaches the bottom of the ramp

$$a = 0.9523 \dots, u = 0, v = 2$$

$$\text{Using } v^2 = u^2 + 2as$$

$$2^2 = 0^2 + 2(0.9523 \dots)s$$

$$s = 2.1000 \dots = 2.10 \text{ m}$$

c Decrease in PE = $mgh = 50 \times 10 \times 2.1 \sin \theta = 131.253 \dots = 131 \text{ J}$

9 a

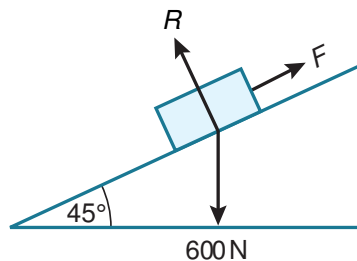

Using Newton's second law perpendicular to the slope

$$R - 600 \cos 45 = 0$$

$$R = 600 \cos 45$$

$$\text{But } F = \mu R = 0.2(600 \cos 45)$$

Newton's second law (parallel to and down the slope)

$$600 \sin 45 - F = 60 a$$

$$600 \sin 45 - 0.2(600 \cos 45) = 60 a$$

$$339.411 \dots = 60 a$$

$$a = 5.656 \dots = 5.66 \text{ m s}^{-2} \text{ as required}$$

b $a = 5.66, u = 0$

$$\text{Using } v^2 = u^2 + 2as$$

$$v^2 = 0^2 + 2(5.66)s$$

$$s = \frac{v^2}{11.32} \text{ m}$$

c Loss in PE = $mgh = 600 \times 10 \times \sin 45 s$

$$\text{From part b } s = \frac{v^2}{11.32} \text{ so loss in PE} = \frac{6000 \sin 45 v^2}{11.32}$$

$$= 37.479 \dots v^2 = 37.5 v^2 \text{ J}$$

d The boy is modelled as a particle, which means air resistance is ignored. Air resistance would slow the boy down, so the slope would be longer and the loss in GPE would be greater than the values given. The slope is modelled as a straight line. In reality it would flatten out towards the bottom, so the boy would slow down while travelling horizontally, his speed at the bottom of the descent would be greater than v and the loss in GPE would be greater than the value given.

10 The slope for the ramp is 1 : 12 meaning $\sin \theta = \frac{1}{12}$

$$\text{KE before} = \frac{1}{2}(90)(2^2) = 180$$

$$\text{KE after} = \frac{1}{2}(90)(4^2) = 720$$

$$\text{Increase in KE} = 720 - 180 = 540 \text{ J}$$

$$\text{Decrease in PE} = mgh = 90 \times 10 \times 8 \sin \theta = 600 \text{ J}$$

$$\text{Change in total mechanical energy} = \text{increase in KE} - \text{decrease in PE} = 540 - 600 = -60 \text{ J}$$

11 Using Newton's second law (vertically upwards)

When using Newton's second law to find the acceleration of the ball, don't forget about the weight of the ball.

$$-0.1t^{0.5} - 0.02g = 0.02a$$

$$a = -5t^{0.5} - 10$$

$$v = \int a dt = \int (-5t^{0.5} - 10) dt = -\frac{5t^{1.5}}{1.5} - 10t + c$$

$$v = \frac{35}{12} \text{ when } t = 0, \text{ so } c = \frac{35}{12}$$

$$v = -\frac{5t^{1.5}}{1.5} - 10t + \frac{35}{12}$$

$$v = 0 \text{ when } -\frac{5t^{1.5}}{1.5} - 10t + \frac{35}{12} = 0$$

Using an equation solver gives $t = 0.25 \text{ s}$

$$s = \int v dt = \int_0^{0.25} \left(-\frac{5t^{1.5}}{1.5} - 10t + \frac{35}{12} \right) dt = \left[-\frac{5t^{2.5}}{3.75} - 5t^2 + \frac{35}{12}t \right]_0^{0.25}$$

$$s = 0.375 \text{ m}$$

$$\text{Increase in PE} = mgh = 0.02 \times 10 \times 0.375 = 0.075 \text{ J}$$

12

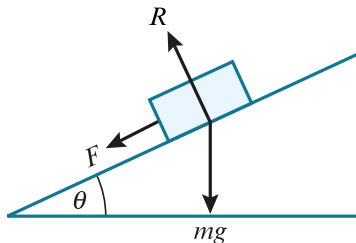

Using Newton's second law perpendicular to the slope

$$R - mg \cos \theta = 0$$

$$R = mg \cos \theta$$

$$\text{But } F = \mu R = \mu mg \cos \theta$$

Using Newton's second law parallel to and up the slope

$$-F - mg \sin \theta = ma$$

$$-\mu mg \cos \theta - mg \sin \theta = ma$$

$$a = -\mu g \cos \theta - g \sin \theta$$

$$a = -\mu g \cos \theta - g \sin \theta, u = v, v = 0$$

$$\text{Using } v^2 = u^2 + 2as$$

$$0^2 = v^2 + 2(-\mu g \cos \theta - g \sin \theta)s$$

$$v^2 = 2(\mu g \cos \theta + g \sin \theta)s$$

$$s = \frac{v^2}{2(\mu g \cos \theta + g \sin \theta)}$$

This is the distance travelled up the slope when the particle comes to rest.

$$\text{Increase in PE} = mgh = mg \sin \theta s$$

$$\begin{aligned} \text{PE} &= mg \sin \theta s = \frac{mg \sin \theta v^2}{2(\mu g \cos \theta + g \sin \theta)} \\ &= \frac{mv^2 \sin \theta}{2(\mu \cos \theta + \sin \theta)} \end{aligned}$$

Divide every term by $\cos \theta$ and using $\frac{\sin \theta}{\cos \theta} = \tan \theta$

$$\text{Increase in PE} = \frac{mv^2 \tan \theta}{2(\mu + \tan \theta)}$$

When PE has increased by $\frac{mv^2 \tan \theta}{2(\mu + \tan \theta)}$ the particle comes to rest.

END-OF-CHAPTER REVIEW EXERCISE 8

1 Work done = $Fd \cos \theta = 180 \times 50 \cos \alpha = 8200$

$$\cos \alpha = \frac{8200}{9000}$$

$$\alpha = 24.340 \dots = 24.3$$

2 a $30 \text{ g} = 0.03 \text{ kg}$

$$\text{Decrease in KE} = \frac{1}{2}mv^2 = \frac{1}{2}(0.03)(4^2) = 0.24 \text{ J}$$

b $80 \text{ cm} = 0.8 \text{ m}$

$$\text{Increase in PE} = mgh = 0.03 \times 10 \times 0.8 = 0.24 \text{ J}$$

3 a $u = 3, v = 20, s = 200$

$$\text{Using } v^2 = u^2 + 2as$$

$$20^2 = 3^2 + 2(200)a$$

$$400 = 9 + 400a$$

$$400a = 391$$

$$a = 0.9775 = 0.978 \text{ m s}^{-2}$$

b Using Newton's second law along the horizontal road

$$D - 40 = ma$$

$$D - 40 = 1600(0.9775)$$

$$D = 1604 \text{ N}$$

$$\text{Work done by driving force} = D \times d = 1604 \times 200 = 320\,800 \text{ J or } 321 \text{ kJ}$$

4 a Work done by the push force = $Fd = 3F = 900$

$$\text{Push force} = 300 \text{ N}$$

b

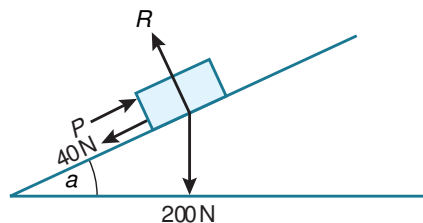

Using Newton's second law (parallel to and up the slope)

$$300 - 40 - 20g \sin \alpha = 20a$$

$$260 - 200 \sin \alpha = 20a$$

$$a = 13 - 10 \sin \alpha \text{ as required}$$

c The push force and resistance are constant.

5 i Work done by the pulling force = 1150 J

$$\text{Increase in KE} = \frac{1}{2}mv^2 = \frac{1}{2}(16)(10^2) = 800 \text{ J}$$

$$\text{Loss in PE} = mgh = 16 \times 10 \times 50 \sin \theta = 400 \text{ J}$$

Work done by pulling force = Increase in KE - loss in PE + work done against the resistance to motion

$$1150 = 800 - 400 + \text{work done against the resistance to motion}$$

$$\text{work done against the resistance to motion} = 750 \text{ J}$$

ii Work done against the resistance to motion is still 750 J

Work done by the pulling force is still 1150 J

Loss in PE is now a gain in PE with the same value of 400 J

Increase in KE is still 800 J

$$800 = \frac{1}{2}mv^2$$

$$800 = \frac{1}{2}(16)v^2$$

$$v = 10 \text{ m s}^{-1} \text{ as before}$$

6 a KE before = $\frac{1}{2}(0.625)(6^2) = 11.25$

$$\text{KE after} = \frac{1}{2}(0.625)(4^2) = 5$$

$$\text{Change in KE} = 11.25 - 5 = 6.25 \text{ J}$$

The change in KE is a decrease as the speed has decreased.

b PE before = $mgh = 0.625 \times 10 \times 2 = 12.5$

$$\text{PE after} = 0.625 \times 10 \times 3 = 18.75$$

$$\text{Change in PE} = 18.75 - 12.5 = 6.25 \text{ J}$$

The change in PE is an increase as the basketball is higher.

c There would be no difference to the numerical answers, but it would affect how far the ball travels horizontally, the height the ball reaches and also the angle that the path of the ball makes with the vertical when the ball passes through the hoop.

7 i

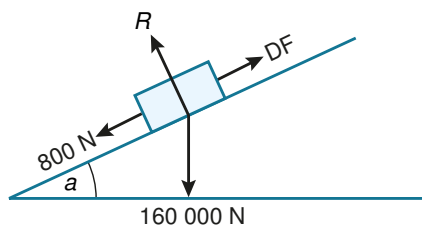

Work done against resistance + increase in PE = work done by driving force

$$\text{Work done against resistance} = Fd = 800 \times 500 = 400\,000$$

$$\text{Increase in PE} = mgh = 16\,000 \times 10 \times 500 \sin \alpha = 80\,000\,000 \sin \alpha$$

$$\text{Work done by driving force} = 2\,800\,000$$

$$400\,000 + 80\,000\,000 \sin \alpha = 2\,800\,000$$

$$80\,000\,000 \sin \alpha = 2\,400\,000$$

$$\sin \alpha = 0.03$$

$$\alpha = 1.719 \dots = 1.7$$

ii

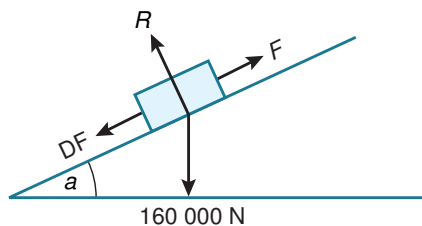

Work done against resistance + increase in KE + increase in PE = work done by driving force

$$\text{Work done against resistance} = 800\,000$$

$$\text{Work done by driving force} = 2\,400\,000$$

$$\text{Increase in KE} = \frac{1}{2}(16\,000)v^2 - \frac{1}{2}(16\,000)(20^2) = 8000v^2 - 3\,200\,000$$

$$\text{Increase in PE} = mgh = 16\,000 \times 10 \times (-500 \sin \alpha) = -80\,000\,000 \sin \alpha = -2\,400\,000$$

$$800\,000 + 8000v^2 - 3\,200\,000 - 2\,400\,000 = 2\,400\,000$$

$$8000v^2 = 7\,200\,000$$

$$v^2 = 900$$

$$v = \pm 30 \text{ so the speed of the lorry is } 30 \text{ m s}^{-1}$$

8 a Using Newton's second law (vertically upwards)

$$R - 200 = 0$$

$$R = 200$$

$$\text{But } F = \mu R = 0.2(200) = 40 \text{ N}$$

Newton's second law (horizontally in the direction of motion)

$$-F = 20a$$

$$-40 = 20a$$

$$a = -2 \text{ so the retardation is } 2 \text{ m s}^{-2}$$

Calculate the acceleration as normal, but as you are asked for the retardation, a final statement regarding the retardation is needed.

b $u = 3, v = 0, a = -2$

$$\text{Using } v^2 = u^2 + 2as$$

$$0^2 = 3^2 + 2(-2)s$$

$$0 = 9 - 4s$$

$$s = 2.25 \text{ m}$$

c Work done against friction = $Fd = 40 \times 2.25 = 90 \text{ J}$

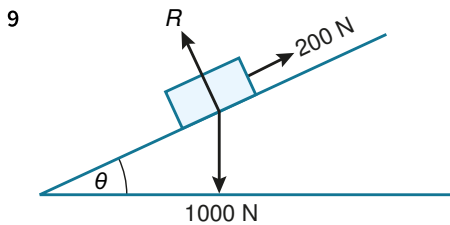

a Increase in KE = $\frac{1}{2}mv^2 = \frac{1}{2}(100)(20^2) = 20\,000 \text{ J}$

b Decrease in PE = $mgh = 100 \times 10 \times 10 = 10\,000 \text{ J}$

c $\sin \theta = \frac{10}{x}$
 $x = \frac{10}{\sin \theta} = \frac{10}{0.2} = 50 \text{ m}$

d Work done against resistance = $Fd = 200 \times 50 = 10\,000 \text{ J}$

10 a Increase in PE = $mgh = \text{weight} \times h = 1280$

$$\text{Weight} \times 2 = 1280$$

$$\text{Weight} = 640 \text{ N}$$

b Work done = $80 = Fd = 20d$

$$d = 4 \text{ m}$$

c Using the height of the slide as 2 m and the length of the slide as 4 m

$$\sin \theta = 2 \div 4 = 0.5$$

$$\theta = 30^\circ$$

d Work done against resistance = decrease in PE – increase in KE

$$\text{Work done against resistance} = 80 \text{ J}$$

$$\text{Decrease in PE} = 1280 \text{ J}$$

$$\text{Increase in KE} = \frac{1}{2}mv^2 = \frac{1}{2}(64)v^2$$

$$80 = 1280 - \frac{1}{2}(64)v^2$$

$$32v^2 = 1200$$

$$v^2 = 37.5$$

$$v = \pm 6.1237 \dots \text{ so speed is } 6.12 \text{ m s}^{-1}$$

11 a Using Newton's second law (perpendicular to the slope)

$$R - 40g \cos \theta = 0$$

$$R = 40g \cos \theta$$

$$F = \mu R = 0.05(40g \cos \theta)$$

Using Newton's second law (parallel to and up the slope)

$$-F - 40g \sin \theta = 40a$$

$$-0.05(40g \cos \theta) - 40g \sin \theta = 40a$$

$$\sin \theta = 0.1 \text{ so } \cos \theta = \sqrt{1 - 0.1^2} = 0.9949\dots$$

$$a = -1.4974\dots \text{ so acceleration is } 1.50 \text{ m s}^{-2} \text{ down the slope}$$

b $u = 5$, $v = 0$, $a = -1.4974\dots$

$$\text{Using } v^2 = u^2 + 2as$$

$$0^2 = 5^2 + 2(-1.4974\dots)s$$

$$s = 8.347\dots = 8.35 \text{ m}$$

c Gain in PE = $mgh = 40 \times 10 \times 8.347\dots \sin \theta = 333.891\dots = 334 \text{ J}$

d Loss in KE = $\frac{1}{2}mv^2 = \frac{1}{2}(40)(5^2) = 500 \text{ J}$

$$\text{Loss in mechanical energy} = \text{loss in PE} + \text{loss in KE} = -333.891\dots + 500 = 166.108\dots = 166 \text{ J as required}$$

Notice the loss in mechanical energy is loss in PE + loss in KE. In part c you found the **gain** in PE so this becomes negative when described as a loss.

12 a The only force acting on Jack during the flight is his weight, which is vertical, so there is no horizontal resultant force and hence no horizontal acceleration.

b Jack's speed is the magnitude of his horizontal and vertical velocity combined.

When Jack hits the trampoline, his horizontal velocity is $12 \cos 45$, the same as his horizontal velocity when he is projected.

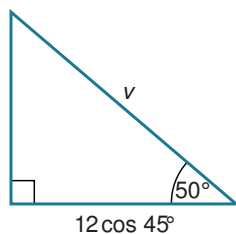

From the triangle, Jack's speed, v can be found from $v \cos 50 = 12 \cos 45$

$$v = \frac{12 \cos 45}{\cos 50} = 13.200\dots = 13.2 \text{ m s}^{-1}$$

c Gain in KE = $\frac{1}{2}mv^2 = \frac{1}{2}(70)(13.2\dots^2) - \frac{1}{2}(70)(12^2) = 1059.097\dots = 1060 \text{ J}$

d Loss in PE = $1059.097\dots = mgh = 70 \times 10h$

$$h = 1.51299\dots = 1.51 \text{ m}$$

e He could easily slide off the trampoline.

f He would bounce up to quite a height and could bounce several times before coming to rest.

Chapter 9

The work–energy principle and power

EXERCISE 9A

Note that some of these questions could alternatively be solved by Newton's second law. However, questions may insist upon the use of the work–energy principle so you should be equally confident with either method.

- 1 a Work done against friction = $Fd = 12 \times 5 = 60 \text{ J}$
b Work done by tension = $Fd = 22 \times 5 = 110 \text{ J}$
c Total work done by all forces = work done by tension – work done against friction = $110 - 60 = 50 \text{ J}$
d Using the work–energy principle

Increase in KE = work done by all forces

The box starts from rest so $u = 0$ and so the initial KE = 0

$$\frac{1}{2}mv^2 = \frac{1}{2}(25)v^2 = 50$$

$$v^2 = 4$$

$$v = \pm 2 \text{ so speed is } 2 \text{ m s}^{-1}$$

State you are using the work–energy principle.

Remember you can think of the work–energy principle as

Increase in KE = work done in speeding up the body – work done in slowing down the body.

- 2 When the rope is inclined at 40° above the horizontal:

$$\text{Work done against friction} = Fd = 12 \times 5 = 60 \text{ J}$$

$$\text{Work done by tension} = Fd \cos 40 = 22 \times 5 \cos 40 = 84.264 \dots$$

$$\text{Total work done by all forces} = \text{work done by tension} - \text{work done against friction} = 84.264 \dots - 60 = 24.264 \dots$$

Increase in KE = work done by all forces

$$\frac{1}{2}mv^2 = \frac{1}{2}(25)v^2 = 24.264 \dots$$

$$v^2 = 1.941 \dots$$

$$v = \pm 1.393 \dots \text{ so speed is } 1.39 \text{ m s}^{-1}$$

When the rope is inclined at 40° above the horizontal, the only change in the calculation is in the work done by the tension.

- 3 a Increase in KE = $\frac{1}{2}mv^2 = \frac{1}{2}(50)(4^2) = 400 \text{ J}$
b Increase in KE + increase in PE = total work done
Increase in KE + increase in PE = 0
So increase in KE = – increase in PE = decrease in PE = 400 J

Decrease in PE = increase in KE because there is no work done by forces either in speeding up or in slowing down the crate.

$$\begin{aligned} \text{c} \quad \text{Decrease in PE} &= mgh = 400 \\ 50 \times 10 h &= 400 \\ h &= 0.8 \text{ m} \end{aligned}$$

$$4 \quad \text{a} \quad \text{Work done by gravity} = mgh = 85 \times 10 \times 3 = 2550 \text{ J}$$

b Increase in KE = work done by gravity

$$\begin{aligned} \frac{1}{2}mv^2 &= \frac{1}{2}(85)v^2 = 2550 \\ v^2 &= 60 \end{aligned}$$

$$v = \pm 7.7459 \dots \text{ so the speed at the end of his descent is } 7.75 \text{ m s}^{-1}$$

Increase in KE = work done by gravity because there is no work done by forces either in speeding up or in slowing down the sledge.

c Increase in KE = work done by gravity

$$\begin{aligned} \frac{1}{2}mv^2 - \frac{1}{2}mu^2 &= mgh \\ \frac{1}{2}mv^2 &= \frac{1}{2}(85 + 35)v^2 = (85 + 35) \times 10 \times 3 = 3600 \\ v^2 &= 60 \end{aligned}$$

$$v = \pm 7.7459 \dots \text{ so the speed at the end of their descent is } 7.75 \text{ m s}^{-1} \text{ as before.}$$

Note the speed at the end of their descent is the same as in part **a** so the velocity does not depend on the mass. You can also see this from the equation at the start of part **c**; as m is present in every term you could cancel through at the start if you wish.

5 a Increase in KE = work done by gravity

$$\begin{aligned} \frac{1}{2}mv^2 - \frac{1}{2}mu^2 &= \frac{1}{2}(50)v^2 - \frac{1}{2}(50)(2^2) = 50 \times 10 \times 5 \\ 25v^2 - 100 &= 2500 \\ v^2 &= 104 \end{aligned}$$

$$v = \pm 10.198 \dots \text{ so the speed at the end of her descent is } 10.2 \text{ m s}^{-1}$$

b Increase in KE = work done by gravity – work done against resistance

$$\begin{aligned} \frac{1}{2}(50)(8^2) - \frac{1}{2}(50)(2^2) &= 50 \times 10 \times 5 - 40s \\ 1600 - 100 &= 2500 - 40s \\ 40s &= 1000 \\ s &= 25 \text{ m} \end{aligned}$$

Now there is work done against resistance to be taken into account, so the work–energy principle becomes: increase in KE = work done by gravity – work done against resistance.

6 Increase in KE = work done by gravity – work done against resistance

$$\begin{aligned} \frac{1}{2}(45)(5^2) - \frac{1}{2}(45)(1^2) &= 45 \times 10 \times 4 - 20R \\ 562.5 - 22.5 &= 1800 - 20R \\ 20R &= 1260 \\ R &= 63 \text{ N} \end{aligned}$$

7 Increase in KE = work done by gravity

Let the mass of the boy be m .

$$\begin{aligned} \frac{1}{2}mv^2 - \frac{1}{2}mu^2 &= \frac{1}{2}m(10^2) - \frac{1}{2}m(0^2) = mgh \\ 50 &= 10h \\ h &= 5 \text{ m} \end{aligned}$$

Notice that although you are not told the mass of the boy, this does not matter as all values of m cancel in the equation when you have only KE and PE terms.

- 8 a Increase in KE = work done by gravity – work done against resistance

$$\frac{1}{2}(50)(9.9^2) - \frac{1}{2}(50)(0^2) = 50 \times 10 \times 5 - 100R$$

$$2450.25 = 2500 - 100R$$

$$100R = 49.75$$

$$R = 0.4975 = 0.498 \text{ N}$$

- b Very small resistance force so the grass is very slippery; perhaps the grass is wet.

- 9 a Loss of gravitational potential energy = $mgh = 40 \times 10 \times 2 = 800 \text{ J}$

- b Let the distance the child travels be d .

Increase in KE = work done by gravity – work done against resistance

$$\frac{1}{2}40(0^2) = 800 - 112d$$

$$0 = 800 - 112d$$

So work done against resistance = loss of gravitational potential energy

$$112d = 800$$

$$d = 7.1428 \dots = 7.14 \text{ m}$$

There is no change in KE as the child starts at rest and ends at rest. There is no need to include KE in the energy equation.

- c Let the length of the sloping part of the slide be s .

$$\sin 30 = \frac{2}{s}$$

$$s = \frac{2}{\sin 30} = 4$$

Then the length of the level part of the slide = $7.1428 \dots - 4 = 3.1428 \dots = 3.14 \text{ m}$

- 10 Let the initial speed be $u \text{ m s}^{-1}$ and the final speed be $v \text{ m s}^{-1}$.

Increase in KE = work done by driving force – work done against resistance

$$\frac{1}{2}(1600)(v^2) - \frac{1}{2}(1600)(u^2) = 2000 \times 200 - 800 \times 200$$

$$800(v^2 - u^2) = 240000$$

$$v^2 - u^2 = 300 \text{ so } v^2 = 300 + u^2 \dots\dots\dots [1]$$

As the driver claims the speed was less than 30, so $v < 30$, or $v^2 < 900$

$$\text{So from [1], } 300 + u^2 < 900$$

$$u^2 < 600$$

$$u < \pm 24.494 \dots \text{ so the initial speed must be less than } 24.5 \text{ m s}^{-1}$$

- 11 a Let the greatest average frictional force be F .

The greatest average frictional force is when the mass is a maximum.

Maximum overall mass is $100 + 2 \times 80 = 260 \text{ N}$

Increase in KE + increase in PE = – work done by friction

Using the maximum overall mass gives

$$\frac{1}{2}(260)(15^2) - 260 \times 10 \times 12 \leq -100F$$

$$29250 - 31200 \leq -100F$$

$$100F \leq 1950$$

$$F \leq 19.5 \text{ N so } F \text{ must be less than } 20 \text{ N as required}$$

- b Let the least average frictional force be G .

Minimum overall mass is $100 + 2 \times 50 = 200 \text{ N}$

Increase in KE + increase in PE = - work done by friction

As the change in PE is a decrease, the increase in PE is a negative value.

Using the minimum overall mass gives

$$\frac{1}{2}(200)(15^2) - 200 \times 10 \times 12 \geq -100G$$

$$22500 - 24000 \geq -100G$$

$$100G \geq 1500$$

$G \geq 15$ so G must be at least 15 N as required

The least average frictional force is when the mass is a minimum.

You could solve parts **a** and **b** by letting the overall mass be m and the average frictional force be F to give

$\frac{1}{2}m(15^2) - m \times 10 \times 12 = -100F$ and so $F = 0.075m$. You can then find the greatest and least average frictional forces from this equation by substituting in the appropriate value for m .

12 a

As the ball is travelling in a circular path, you need to use the work-energy method to solve. This is because acceleration is not constant for motion on a curve.

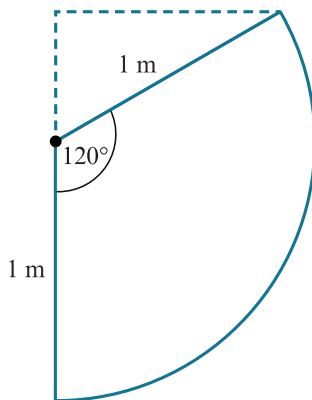

Gain in gravitational potential energy = $mgh = 1 \times 10 \times (1 + \cos 60) = 15 \text{ J}$

b Decrease in KE = gain in gravitational potential energy

$$\frac{1}{2}(1)v^2 - \frac{1}{2}(1)u^2 = 15$$

$$v^2 - u^2 = 30$$

$$u^2 = v^2 - 30$$

$$u = \sqrt{v^2 - 30} \text{ m s}^{-1} \text{ as required}$$

c Using $u = \sqrt{v^2 - 30}$ when $v = 8$, $u = \sqrt{8^2 - 30} = \sqrt{34} = 5.830 \dots = 5.83 \text{ m s}^{-1}$

You can use the result from part **b**.

d Using $u = \sqrt{v^2 - 30}$ when $u = 0$, $\sqrt{v^2 - 30} = 0$

$$v^2 = 30$$

$$v = 5.477 \dots = 5.48 \text{ m s}^{-1}$$

e

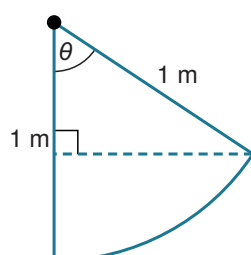

When $\theta < 90^\circ$, gain in gravitational potential energy = $mgh = 1 \times 10 \times (1 - \cos \theta)$

Decrease in KE = gain in gravitational potential energy

$$\frac{1}{2}(1)(3.5^2) - \frac{1}{2}(1)(0^2) = 1 \times 10 \times (1 - \cos \theta)$$

$$1 - \cos \theta = 0.6125$$

$$\cos \theta = 0.3875$$

$$\theta = 67.200\dots = 67.2^\circ$$

The result from part **b** now cannot be used as it is only valid for when $\theta = 120^\circ$. Draw a new diagram to consider the gain in gravitational potential energy when $\theta < 90^\circ$.

f When $\theta = 180^\circ$, gain in gravitational potential energy = $mgh = 1 \times 10 \times 2 = 20 \text{ J}$

Decrease in KE = gain in gravitational potential energy

$$\frac{1}{2}(1)v^2 = 20$$

$$v^2 = 40$$

$$v = 6.324\dots = 6.32 \text{ m s}^{-1}$$

For the ball to just make a complete circle, the speed at the top of the circular path is 0 m s^{-1} , the angle travelled through is 180° and the height gained by the ball is $2 \times \text{radius} = 2 \text{ m}$.

EXERCISE 9B

- 1 Increase in KE = decrease in PE

Height of slope = $3.5 \sin 20$

$$\frac{1}{2}(3)(8^2) - \frac{1}{2}(3)(u^2) = 3 \times 10 \times 3.5 \sin 20$$

$$96 - 1.5u^2 = 35.912 \dots$$

$$1.5u^2 = 60.087 \dots$$

$$u^2 = 40.058 \dots$$

$u = \pm 6.329 \dots$ so the speed at the top of the slope was 6.33 m s^{-1}

When you find the increase in PE, remember that h is the change in vertical height, not the distance travelled along the slope.

- 2 Increase in KE = decrease in PE

$$\frac{1}{2}mv^2 = m \times 10 \times 1.43$$

$$v^2 = 28.6$$

$v = \pm 5.347 \dots$ so the speed of the plate when it hits the floor is 5.35 m s^{-1}

Note that although the mass of the plate is unknown, you can still find its speed as, in the first equation of the question, m can be cancelled in each term. This shows that in the absence of resistance all objects will fall at the same speed.

- 3 a $57 \text{ g} = 0.057 \text{ kg}$

Increase in gravitational potential energy = $mgh = 0.057 \times 10 \times 1 = 0.57 \text{ J}$

b $180 \text{ km h}^{-1} = \frac{180 \times 1000}{60^2} = 50 \text{ m s}^{-1}$

Decrease in KE = increase in PE

$$\frac{1}{2}(0.057)(50^2) - \frac{1}{2}(0.057)(v^2) = 0.57$$

$$50^2 - v^2 = 20$$

$$v^2 = 2480$$

$v = \pm 49.799 \dots$ so the horizontal speed of the ball at the top of its flight is 49.8 m s^{-1} or $\frac{49.8 \times 60^2}{1000} = 179 \text{ km h}^{-1}$

Remember to change the mass and speed to SI units.

- 4 $20 \text{ cm} = 0.2 \text{ m}$

Increase in KE = decrease in PE

$$\frac{1}{2}mv^2 = m \times 10 \times 0.2$$

$$v^2 = 4$$

$v = \pm 2$ so the speed of the box at the bottom of the ramp is 2 m s^{-1}

- 5 Decrease in KE = increase in PE

Height of slope = $2.5 \sin 30 = 1.25 \text{ m}$

$$\frac{1}{2}mv^2 = m \times 10 \times 1.25$$

$$v^2 = 25$$

$v = \pm 5$ so the launch speed of the ball is 5 m s^{-1}

- 6 Decrease in KE = increase in PE

Height of slope = $1.2 \sin 10$

Let v be the launch speed for the ball bearing.

For the ball bearing to stop at start of slope:

$$\frac{1}{2}mv^2 = m \times 10 \times 1.2 \sin 10$$

$$v^2 = 24 \sin 10$$

$v = \pm 2.0414 \dots$ so the maximum initial speed of the ball bearing is 2.04 m s^{-1}

7 Height of hill is h m

Increase in KE = decrease in PE

$$\frac{1}{2}mv^2 = mgh$$

$$0.5v^2 = 10h$$

$$h = 0.05v^2 \text{ m}$$

As in the previous exercise, not knowing the mass of the boy does not matter as all values of m cancel in the equations when you have only KE and PE terms.

8 a Increase in KE = decrease in PE

$$\frac{1}{2}mv^2 - \frac{1}{2}mu^2 = mgh$$

$$v^2 - u^2 = 200$$

$$v^2 = 200 + u^2$$

$$v = \left(\sqrt{200 + u^2}\right) \text{ m s}^{-1}$$

b The diver is modelled as a particle so there is no air resistance, no spin, etc. The end of the board is assumed to be 10 m above the water at take-off, but if it is a flexible board it may be less (or more) than 10 m.

9 a Decrease in KE = increase in PE

$$\frac{1}{2}m(15^2) - \frac{1}{2}mv^2 = m \times 10 \times 1$$

$$225 - v^2 = 20$$

$$v^2 = 205$$

$v = \pm 14.317 \dots$ so the speed of the ball is 14.3 m s^{-1}

b The only force acting is the weight, which is vertically downwards, so there is no horizontal component to the acceleration.

c The horizontal component of the velocity remains at $15 \cos \theta$.

The vertical component of the velocity is zero when the ball reaches the top of its flight.

The overall velocity of the ball at the top of its flight is then $15 \cos \theta$.

Decrease in KE = increase in PE

$$\frac{1}{2}m(15^2) - \frac{1}{2}m(15 \cos \theta)^2 = m \times 10 \times 1.45$$

$$225 - 225 \cos^2 \theta = 29$$

$$\cos^2 \theta = 0.871$$

$$\cos \theta = 0.93$$

$\theta = 21.039 \dots = 21.0^\circ$ as required

From part b there is no horizontal component to the acceleration, meaning the horizontal component of the velocity does not change throughout the flight so remains at $15 \cos \theta$.

10 a i Decrease in PE for the ball = $10mh$ J

ii Increase in KE for the ball $0.5mv^2$ J

iii Increase in height of the crate is $h \sin \theta$

Increase in mechanical energy = increase in KE for the crate + increase in PE for the crate

Increase in mechanical energy = $0.5 Mv^2 + 10Mh \sin \theta$ J

- b Increase in mechanical energy for the crate = decrease in mechanical energy for the ball

$$0.5Mv^2 + 10Mh \sin \theta = 10Mh - 0.5mv^2$$

$$0.5mv^2 + 0.5Mv^2 = 10Mh - 10Mh \sin \theta$$

$$\frac{v^2(m + M)}{2} = 10h(m - M \sin \theta)$$

$$v^2 = \frac{20h(m - M \sin \theta)}{(m + M)}$$

$$v = \sqrt{\frac{20h(m - M \sin \theta)}{(m + M)}} \text{ as required}$$

The decrease in mechanical energy for the ball is the decrease in PE for the ball minus the increase in KE for the ball.

- 11 a i Increase in KE = decrease in PE

$$\frac{1}{2}(0.2)v^2 = 0.2 \times 10 \times 2.45$$

$$0.1v^2 = 4.9$$

$$v^2 = 49$$

$v = 7$ so the speed of the particle when it is at B is 7 m s^{-1}

As B is level with the centre of the circle, when the particle reaches B it has fallen a height equal to the radius of 2.45 m.

- ii Increase in KE = decrease in PE

$$\frac{1}{2}(0.2)v^2 = 0.2 \times 10 \times 6.05$$

$$0.1v^2 = 12.1$$

$$v^2 = 121$$

$v = 11$ so the speed of the particle when it is at B is 11 m s^{-1}

When the particle reaches C it has fallen a height equal to the radius of 2.45 m plus the further 3.6 m to the floor, which is 6.05 m.

- b The surface is smooth, so there is no frictional force acting on the particle.

- c If the mass is doubled, part i becomes

$$\frac{1}{2}(0.4)v^2 = 0.4 \times 10 \times 2.45$$

$$0.2v^2 = 9.8$$

$v^2 = 49$ so the speed at B is still 7 m s^{-1}

and part ii becomes

$$\frac{1}{2}(0.4)v^2 = 0.4 \times 10 \times 6.05$$

$$0.2v^2 = 24.2$$

$v^2 = 121$ so the speed at C is still 11 m s^{-1}

There is no difference if the mass of the particle is doubled.

There is no difference if the mass of the particle is doubled because all values of m cancel in the equations when you have only KE and PE terms.

- 12 a Increase in KE = decrease in PE

Let the mass of the boy and his skateboard be m .

$$\frac{1}{2}mv^2 - \frac{1}{2}m(2^2) = m \times 10 \times 0.8$$

$$\frac{1}{2}v^2 - 2 = 8$$

$$v^2 = 20$$

$v = 4.472 \dots$ so the speed of the boy at the bottom of the circle is 4.47 m s^{-1}

When the boy reaches the bottom of the circle his height has decreased by a value equal to the diameter of the circle, which is 0.8 m .

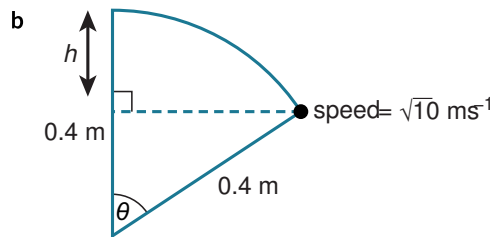

Increase in KE = decrease in PE

$$\frac{1}{2}m(\sqrt{10})^2 - \frac{1}{2}m(2^2) = m \times 10 \times (0.4 - 0.4 \cos \theta)$$

$$5 - 2 = 4 - 4 \cos \theta$$

$$4 \cos \theta = 1$$

$$\cos \theta = 0.25$$

$\theta = 75.522 \dots$ so the angle is 75.5°

From the diagram, the height has decreased by $0.4 - 0.4 \cos \theta$.

EXERCISE 9C

- 1 a Increase in KE + increase in PE = work done

Let the length of the slide be d .

$$\frac{1}{2}(60)(10^2) - 60 \times 10 \times 7 = -50d$$

$$50d = 4200 - 3000 = 1200$$

$$d = 24 \text{ m}$$

As the PE is a decrease, it becomes negative when inserted into the equation. Also, the work done here is work done against friction, so this is also a negative amount.

- b mechanical energy at the start = $60 \times 10 \times 7 = 4200 \text{ J}$ (as there is only PE)

$$\text{mechanical energy at the end} = \frac{1}{2}(60)(10^2) = 3000 \text{ J (as there is only KE)}$$

$$\text{mechanical energy lost} = 4200 - 3000 = 1200 \text{ J}$$

Remember mechanical energy = PE + KE

- c Most of the mechanical energy lost is changed into heat energy.

2

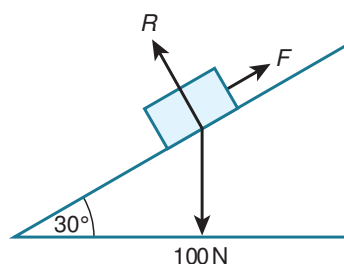

Increase in KE + increase in PE = work done

The work done is against friction, so you need to find the frictional force acting on the box.

Let the coefficient of friction between the box and the slope be μ .

Newton's second law (perpendicular to the plane)

$$R - 100 \cos 30 = 0 \text{ so } R = 100 \cos 30$$

$$F = \mu R = 100\mu \cos 30$$

$$\frac{1}{2}(10)(5^2) - \frac{1}{2}(10)(3.25^2) - 10 \times 10 \times 3 \sin 30 = -100\mu \cos 30 \times 3$$

$$-77.8125 = -259.807 \dots \mu$$

$$\mu = 0.29950 \dots = 0.300$$

Use Newton's second law perpendicular to the plane to find the normal contact force, then use $F = \mu R$ to find an expression for the frictional force. Remember the work done against friction is then $-Fd$.

- 3 mechanical energy at the top = $12 \times 10 \times 2 = 240 \text{ J}$ (as there is only PE)

$$\text{mechanical energy at the bottom} = \frac{1}{2}(12)(6^2) = 216 \text{ J (as there is only KE)}$$

$$\text{mechanical energy lost (or dissipated)} = 240 - 216 = 24 \text{ J}$$

Remember mechanical energy = PE + KE

- 4 $u = 0$, $a = 10$, $s = 1000$

$$\text{Using } v^2 = u^2 + 2as$$

$$v^2 = 0^2 + 2(10)(1000) = 20000$$

$$v = \sqrt{20000} \text{ m s}^{-1}$$

Let the average resistance force when the skydiver is falling be R

Increase in KE + increase in PE = work done

$$\begin{aligned}\frac{1}{2}(80)(5^2) - \frac{1}{2}(80)(20\,000) - 80 \times 10 \times 2000 &= -2000R \\ -2\,399\,000 &= -2000R \\ R &= 1199.5 = 1200 \text{ N}\end{aligned}$$

Use equations of constant acceleration to find the speed when the skydiver opens his parachute, then the work – energy principle to find the average resistance.

5 Let the frictional force between the tile and the roof be F .

Increase in KE + increase in PE = work done

$$\begin{aligned}\frac{1}{2}(1)(10.5^2) - 1 \times 10 \times (3 \sin 20 + 5) &= -3F \\ 3F &= 5.1356043 \\ F &= 1.711868 = 1.71 \text{ N}\end{aligned}$$

The height lost by the tile is $3 \sin 20$ (the height lost when it reaches the edge of the roof) plus 5 (the vertical distance to the ground), giving an overall height loss of $3 \sin 20 + 5$.

6 $50g = 0.05 \text{ kg}$

Increase in PE = work done

Let the distance the car has travelled be s .

$$\begin{aligned}-0.05 \times 10 \times 2 &= -0.05s \\ s &= 20 \text{ m}\end{aligned}$$

There is no change in KE as the car starts from rest and ends at rest.

7 Increase in KE + increase in PE = work done

Let the distance the diver has travelled be s and the mass of the diver be m .

The resistance acting on the diver is 0.5 N kg^{-1} so the resistance force acting on a diver of mass m will be $0.5m \text{ N}$.

$$\begin{aligned}-\frac{1}{2}mu^2 + mgs &= -0.5ms \\ 0.5s + gs &= 0.5u^2 \\ 10.5s &= 0.5u^2 \\ s &= \frac{0.5u^2}{10.5} = \frac{u^2}{21}\end{aligned}$$

Therefore the total height of the diver above the swimming pool at the highest point of the dive is $\left(10 + \frac{u^2}{21}\right) \text{ m}$

Remember both the decrease in PE and the work done against resistance will contain s , and that the diver is initially travelling upwards!

8 a $45.9 \text{ g} = 0.0459 \text{ kg}$

Increase in KE + increase in PE = work done

Let the speed of the ball just before it hits the water be v .

$$\begin{aligned}\frac{1}{2}(0.0459)v^2 - \frac{1}{2}(0.0459)(50^2) - 0.0459 \times 10 \times 5 &= -0.3 \times 160 \\ 0.02295v^2 - 57.375 - 2.295 &= -48 \\ 0.02295v^2 &= 11.67 \\ v^2 &= 508.496 \dots\end{aligned}$$

$v = 22.54 \dots$ so the speed of the ball just before it hits the water is 22.5 m s^{-1}

b The energy at the point of impact is kinetic, and is equal to $\frac{1}{2}(0.0459)(22.54 \dots)^2 = 11.6699 \dots \text{ J}$

8 J are absorbed, so the kinetic energy of the ball is now $11.6699 \dots - 8 = 3.6699 \dots \text{ J}$

Work – energy equation for the ball from the moment it hits the water until it comes to rest at the bottom of the pond:

Increase in KE + increase in PE = work done

Let the depth of the pond be s .

$$-3.6699 \dots - 0.0459 \times 10 \times s = -3s$$

$$s(3 - 0.459) = 3.6699 \dots$$

$$2.541s = 3.6699 \dots$$

$$s = 1.444 \dots = 1.44 \text{ m}$$

9 a $45.9 \text{ g} = 0.0459 \text{ kg}$

$$180 \text{ km h}^{-1} = \frac{(180 \times 1000)}{(60 \times 60)} = 50 \text{ m s}^{-1}$$

$$144 \text{ km h}^{-1} = \frac{(144 \times 1000)}{(60 \times 60)} = 40 \text{ m s}^{-1}$$

Increase in KE + increase in PE = work done

Let the magnitude of the average resistance force acting on the golf ball be R .

$$\frac{1}{2}(0.0459)(40^2) - \frac{1}{2}(0.0459)(50^2) + 0.0459 \times 10 \times 20 = -61.875R$$

$$61.875R = 11.475$$

$$R = 0.18545 \dots = 0.185 \text{ N}$$

Remember to change the mass and speed to SI units.

b Increase in KE + increase in PE = work done

Use the starting point of the golf ball at the tee.

$$\frac{1}{2}(0.0459)v^2 - \frac{1}{2}(0.0459)(50^2) - 0.0459 \times 10 \times 4 = -0.18545 \dots \times (61.875 + 105.8)$$

$$0.02295v^2 = 28.115 \dots$$

$$v^2 = 1225.08 \dots$$

$$v = 35.001 \dots = 35 \text{ m s}^{-1} \text{ or } 126 \text{ km h}^{-1}$$

c The energy of the golf ball at impact is kinetic and is equal to $\frac{1}{2}(0.0459)(35^2) = 28.113 \dots = 28.1 \text{ J}$

As the ball is brought to rest, all this energy is absorbed by the green.

10 a Increase in KE + increase in PE = work done

Let x be the number of rotations the ball has made.

$$\frac{1}{2}(2)(0.2^2) + \frac{1}{2}(5)(0.2^2) + 2 \times 10 \times 1.6 - 5 \times 10 \times 1.6 = -10x$$

$$0.04 + 0.1 + 32 - 80 = -10x$$

$$10x = 47.86$$

$$x = 4.786 = 4.79 \text{ rotations}$$

The increase in KE of the system is the increase in KE of each ball, and the increase in PE of the system is the increase in PE of each ball. However, the ball of mass 5 kg has a decrease in PE as this has a heavier weight so will move downwards whereas the ball of mass 2 kg has a lighter weight so will move upwards.

b $2\pi r \times 4.786 = 1.6$

$$r = \frac{1.6}{9.572\pi} = 0.05320 \dots$$

$$= 0.0532 \text{ m} = 5.32 \text{ cm}$$

The distance each particle has moved, 1.6 m, is the same as the number of rotations of the pulley multiplied by the circumference of the pulley.

11 a Increase in KE + increase in PE = work done

Let the average resistive force acting on the woman be R .

$$\frac{1}{2}(5.4)(7^2) - \frac{1}{2}(5.4)(1^2) - 54 \times 3 = -16.2R$$

$$132.3 - 2.7 - 162 = -16.2R$$

$$16.2R = 32.4$$

$$R = 2 \text{ N}$$

Note the weight of the woman is given as 54 N so her mass is $54 \div 10 = 5.4 \text{ kg}$.

b $\frac{1}{2}(5.4)v^2 - \frac{1}{2}(5.4)(1^2) - 54 \times 3 = -16.2R$

$$2.7v^2 - 2.7 - 162 = -16.2R$$

$$16.2R = -2.7v^2 + 164.7$$

$$\frac{81R}{5} = -\frac{27v^2}{10} + \frac{1647}{10}$$

$$R = -\frac{v^2}{6} + \frac{61}{6} = \left(\frac{61 - v^2}{6}\right) \text{ N}$$

The equations in part **b** are the same as in part **a** but replace 7 with v .

You could give the answer using decimals, as an exact answer is not requested, but the fractional answer is more elegant.

12 a Decrease in mechanical energy = $0.2 \times 10 \times 2.45 + 0.2 \times 10 \times 3.6 - \frac{1}{2}(0.2)(10^2) = 2.1 \text{ J}$

The decrease in mechanical energy for the particle is the decrease in PE in moving from A to B plus the decrease in PE in moving from B to C minus the increase in KE in moving from A to C .

b Let the average frictional force between the surface and the particle be F .

$$Fd = 2.1$$

The distance the average frictional force acts for is a quarter of the circumference of the circle, or $\frac{2\pi(2.45)}{4}$

$$\text{So } \frac{2\pi(2.45)}{4}F = 2.1$$

$$1.225\pi F = 2.1$$

$$F = 0.5456\dots = 0.546 \text{ N as required}$$

The average frictional force can be found from:

$$\text{work done by the frictional force} = \text{loss in mechanical energy} = 2.1 \text{ J}$$

c At the start of the motion when the particle is on the top of the sculpture the normal contact force is 2 N and $0.546 \div 2 = 0.273$. However, as the particle moves down the surface of the sculpture the frictional force reduces to 0. The value 0.546 N for the frictional force is an average and at the start the frictional force is greater than this, and so the value of μ must be greater than 0.273.

EXERCISE 9D

- 1 a $0.5 \times 2000 \times (20^2 - 10^2) = \text{WD by engine}$
 $\text{WD} = 300000 \text{ J or } 300 \text{ kJ}$

Increase in KE = WD by engine

- b Average power = $300\,000 \div 8 = 37\,500 \text{ W or } 37.5 \text{ kW}$

Average power = $\text{WD} \div \text{time taken}$

- 2 $400 \text{ kW} = 400\,000 \text{ W}$

Resultant force = driving force – 20 000

At the maximum speed, acceleration = 0 so at this point, resultant force = 0

So driving force = 20 000 N

Power = driving force \times speed

$$400\,000 = 20\,000 \times \text{speed}$$

speed = 20 so the maximum speed the truck can achieve is 20 m s^{-1}

Use Newton's second law to find the driving force.

- 3 $140 \text{ kW} = 140\,000 \text{ W}$

Resultant force = driving force – 10 000

At the maximum speed, acceleration = 0 so at this point, resultant force = 0

So driving force = 10 000 N

Power = driving force \times speed

$$140\,000 = 10\,000 \times \text{speed}$$

speed = 14 so the maximum speed the boat can achieve is 14 m s^{-1}

As you have not used the mass of the boat, the maximum speed is the same for any engine that has this maximum power and this resistance to motion.

- 4 Increase in KE = WD by engine

$$0.5 \times 0.2 \times (8^2 - 2^2) = \text{WD by engine}$$

$$\text{WD} = 6 \text{ J}$$

Average power = $\text{WD} \div \text{time taken}$

$$\text{Average power} = 6 \div 3 = 2 \text{ W}$$

- 5 $120 \text{ kW} = 120\,000 \text{ W}$

Maximum power = driving force \times maximum speed

$$120\,000 = \text{DF} \times 10$$

$$\text{DF} = 12\,000 \text{ N}$$

Resultant force = 12 000 – resistance force

At the maximum speed, acceleration = 0 so at this point, resultant force = 0

So resistance force = 12 000 N = 12 kN

6

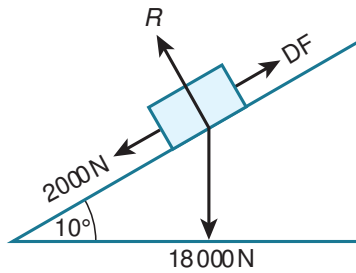

Use Newton's second law (parallel to and up the slope)

$$DF - 2000 - 18000 \sin 10 = 0 \text{ (remember the car is driven at a constant speed so } a = 0)$$

$$DF = 2000 + 18000 \sin 10$$

$$\begin{aligned} \text{Power} &= \text{driving force} \times \text{speed} = (2000 + 18000 \sin 10) \times 15 \\ &= 76885 \dots \\ &= 76900 \text{ W or } 76.9 \text{ kW} \end{aligned}$$

The rate at which the engine is working is the same as the power of the engine.

7 Assuming constant acceleration, $u = 10$, $v = 12$, $t = 60$

Using $v = u + at$

$$12 = 10 + 60a$$

$$a = \frac{1}{30} \text{ ms}^{-2}$$

Use Newton's second law (parallel to and up the slope)

$$\frac{P}{11} - 16000 \sin 10 = 1600 \left(\frac{1}{30} \right)$$

$$P = 31148.7 \dots$$

$$P = 31.1 \text{ kW}$$

Driving force = power \div speed

8

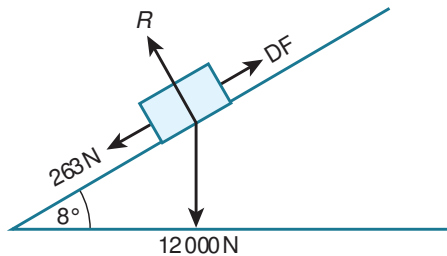

$$75 \text{ kW} = 75000 \text{ W}$$

Power = driving force \times speed

$$\text{At this particular instant, } 75000 = DF \times 25 \text{ so } DF = 3000 \text{ N}$$

Use Newton's second law (parallel to and up the slope)

$$DF - 263 - 12000 \sin 8 = 1200a$$

$$3000 - 263 - 12000 \sin 8 = 1200a$$

$$1200a = 1066.922 \dots$$

$$a = 0.8891 \dots = 0.889 \text{ m s}^{-2}$$

9 a $48 \text{ kW} = 48000 \text{ W}$

Power = driving force \times speed

$$48000 = DF \times v$$

$$DF = \left(\frac{48000}{v} \right) \text{ N}$$

b Use Newton's second law (horizontally in the direction of motion)

$$DF - 2400 = 1600a$$

$$\left(\frac{48000}{v}\right) - 2400 = 1600a$$

$$a = \left(\frac{30}{v} - 1.5\right) \text{ m s}^{-2}$$

- c If the initial value of v is zero the initial driving force and the initial acceleration would both be infinite, as in each case they have v in the denominator of their expressions.

- 10 a Resultant force = driving force – 15

At the maximum speed, acceleration = 0 so at this point, resultant force = 0

So driving force = 15 N

Maximum power = driving force × maximum speed

$$750 = 15 \times \text{maximum speed}$$

$$\text{Maximum speed} = 50 \text{ m s}^{-1}$$

- b Maximum speed = 25 m s⁻¹

Maximum power = driving force × maximum speed

$$\text{Driving force} = 750 \div 25 = 30 \text{ N}$$

Resultant force = 30 – resistance = 0 as the acceleration = 0

So the resistance has changed and is now 30 N

11

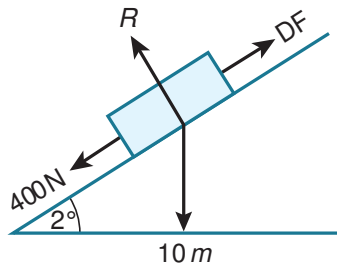

When $v = 20 \text{ m s}^{-1}$ driving force = $30\,000 \div 20 = 1500 \text{ N}$

Use Newton's second law (in the direction of motion)

$$\text{DF} - 400 - 10 m \sin 2 = 0.1 m$$

$$1500 - 400 = m(0.1 + 10 \sin 2)$$

$$1100 = m(0.1 + 10 \sin 2)$$

$$m = 2449.9 \dots = 2450$$

Power = driving force × speed

- 12 a 25 kW = 25 000 W

Work done by engine = average power × time = $25\,000 \times 5$

$$\text{Energy dissipated} = 25\,000 \times 5 + 0.5 \times 1250 \times (10^2 - v^2)$$

$$= 125\,000 + 625(100 - v^2)$$

$$= 625(300 - v^2) \text{ J}$$

Let the distance travelled during this time be s .

But also energy dissipated = WD against resistance = $500s$

$$\text{So } 625(300 - v^2) = 500s$$

$$s = 1.25(300 - v^2) \text{ m}$$

Energy dissipated = WD by engine + loss in KE (as there is no loss in PE)

- b Use Newton's second law (horizontally in the direction of motion)

$$\text{DF} - 500 = 1250a$$

$$\text{DF} = 25\,000 \div v$$

$$\frac{25\,000}{v} - 500 = 1250a$$

$$a = \left(\frac{20}{v} - 0.4 \right) \text{ m s}^{-2}$$

As v varies, a varies, so it is not constant acceleration.

Driving force = power \div speed

- c Car B has a constant acceleration after 5 s of $\frac{20}{v} - 0.4$, which means equations of constant acceleration can be used.

$$a = \frac{20}{v} - 0.4, u = 10, t = 5$$

Using $v = u + at$

$$v = 10 + \left(\frac{20}{v} - 0.4 \right) (5)$$

$$v^2 = 10v + (20 - 0.4v)(5)$$

$$v^2 = 10v + 100 - 2v$$

$$v^2 - 8v = 100 \text{ as required}$$

$$v^2 - 8v - 100 = 0$$

Using $\frac{-b \pm \sqrt{b^2 - 4ac}}{2a}$

$$v = \frac{8 \pm \sqrt{8^2 - 4(-100)}}{2} = \frac{8 \pm \sqrt{464}}{2}$$

$$v = 14.770 \dots \text{ or } -6.770 \dots$$

But the question states car B accelerates from 10 m s^{-1} so the speed of the cars at the end of the 5 s is 14.8 m s^{-1} .

END-OF-CHAPTER REVIEW EXERCISE 9

- 1 Resultant force = mass \times acceleration

$$\frac{P}{19} - R = (1250)(0.6) = 750 \dots\dots [1]$$

$$\frac{P}{30} - R = (1250)(0.16) = 200 \dots\dots [2]$$

$$[1] - [2]$$

$$\frac{P}{19} - \frac{P}{30} = 750 - 200$$

$$\frac{11P}{570} = 550$$

$$P = 28\,500$$

$$\frac{28\,500}{19} - R = 750$$

$$\text{so } R = 750$$

Use driving force = power \div speed and Newton's second law (horizontally in the direction of motion) to create simultaneous equations in P and R .

Note that you should give the answer as 28 500, not 28 500 W or 28.5 kW, as the power has been defined as P W.

- 2 a Newton's second law for mass Y (vertically downwards)

$$10m - T = ma \dots\dots [1]$$

Newton's second law for mass X (vertically upwards)

$$T - 20 = 2a \dots\dots\dots [2]$$

$$\text{From } [2] \ a = \frac{T - 20}{2}$$

$$\text{Into } [1] \ 10m - T = \left(\frac{T - 20}{2}\right)m$$

$$10m - T = \left(\frac{T - 20}{2}\right)m$$

$$20m - 2T = Tm - 20m$$

$$40m = Tm + 2T$$

$$T(m + 2) = 40m$$

$$T = \left(\frac{40m}{m + 2}\right) \text{ N}$$

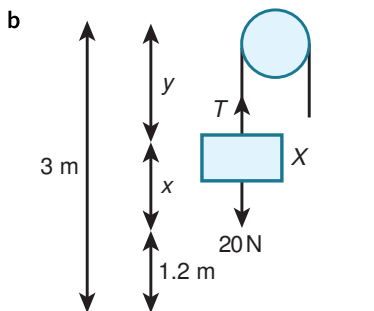

As you do not know the energy absorbed by the floor when Y reaches the ground, use the work–energy principle on particle X only.

At the start of the motion, PE and KE are both zero.

When X reaches its highest point:

$$\text{PE} = 2 \times 10 \times (3 - y) = 20(3 - y)$$

To find the work done by the pulley, you need to know how far the particles move whilst the string is in tension. Particle X starts at ground level, 3 m below the pulley. The string is 4.8 m long, so particle Y starts 4.8 – 3 = 1.8 m below the pulley. Hence Y starts 3 – 1.8 = 1.2 m above the ground, so the string is in tension for 1.2 m.

$$\text{Work done by the pulley} = Fd = \left(\frac{40m}{m+2} \right) (1.2)$$

Using the work–energy principle

$$20(3 - y) = \left(\frac{40m}{m+2} \right) (1.2)$$

$$3 - y = \frac{2.4m}{m+2}$$

$$y = 3 - \frac{2.4m}{m+2} = \frac{3m+6-2.4m}{m+2} = \frac{0.6m+6}{m+2} = \left(\frac{0.6(m+10)}{m+2} \right) \text{ m}$$

This could also have been solved using Newton's second law. You already have the acceleration in terms of T from part **a** for when the string is taut. You would then need to find the velocity when Y hits the floor, to find the velocity when X starts to rise under gravity. However, the question states you must use the work–energy principle so you would need to demonstrate this here.

3 Increase in KE + increase in PE = work done

$$\frac{1}{2}(1500)v^2 - \frac{1}{2}(1500)(0^2) + 1500 \times 10 \times x \sin \alpha = (2000 - 350)x$$

$$750v^2 + 1500x = 1650x$$

$$750v^2 = 150x$$

$$v^2 = \frac{x}{5}$$

$$v = \sqrt{\frac{x}{5}}$$

4 a Use driving force = power \div speed and Newton's second law (horizontally in the direction of motion).

$$\frac{50000}{v} - 200 - 1000 \times 10 \times \sin \alpha = (1000)(1.2)$$

$$\frac{50000}{v} = 1900$$

$$v = 26.315... = 26.3 \text{ m s}^{-1}$$

b Use Newton's second law again, but with the mass as m

$$\frac{50000}{v} - 200 - m \times 10 \times \sin \alpha = 0.2m$$

$$\frac{50000}{v} - 200 = 10m \sin \alpha + 0.2m$$

As the mass increases, the right side of the equation increases, and so the left side increases.

As 200 is a constant, $\frac{50000}{v}$ increases so for this to happen v must decrease.

c Use Newton's second law again, but with the power as P .

$$\frac{P}{v} - 200 - 1000 \times 10 \times \sin \alpha = (1000)0.2$$

$$\frac{P}{v} = 1900$$

$\frac{P}{v}$ equals a constant, so if the power is reduced v must also reduce.

5 Increase in KE + increase in PE = work done

$$\frac{1}{2}(3000)v^2 - \frac{1}{2}(3000)(0^2) + 3000 \times 10 \times x \sin \alpha = (7000 - 4000)x$$

$$1500v^2 + 2400x = 3000x$$

$$1500v^2 = 600x$$

$$x = 2.5v^2$$

So to 3 significant figures, $k = 2.50$

6 a 100 kW = 100 000 W

Resultant force = driving force – 5 000

At the maximum speed, acceleration = 0 so at this point, resultant force = 0

So driving force = 5 000 N

Power = driving force \times speed

100 000 = 5 000 \times speed

speed = 20 so the maximum speed the car can achieve is 20 m s⁻¹

b Use driving force = power \div speed and Newton's second law (horizontally in the direction of motion).

$$\frac{P}{15} - 5000 = (1200)(-2)$$

$$\frac{P}{15} - 5000 = -2400$$

$$\frac{P}{15} = 2600$$

$$P = 39000\text{W or } 39\text{ kW}$$

7

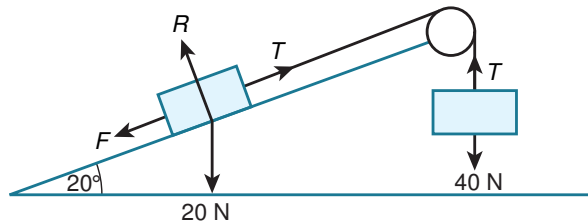

Newton's second law on the 2 kg mass (perpendicular to the plane)

$$R - 20 \cos 20 = 0 \text{ so } R = 20 \cos 20$$

$$F = \mu R = 0.3 \times 20 \cos 20 = 6 \cos 20$$

Newton's second law on the 2 kg mass (parallel to and up the plane)

$$T - 20 \sin 20 - 6 \cos 20 = 2a \dots\dots\dots [1]$$

Newton's second law on the 4 kg mass (vertically downwards)

$$40 - T = 4a \dots\dots\dots [2]$$

Adding [1] and [2] gives

$$40 - 20 \sin 20 - 6 \cos 20 = 6a$$

$$a = 4.586 \dots$$

$$\text{From [2]} T = 40 - 4a = 40 - 4(4.586 \dots) = 21.652 \dots \text{ N}$$

Increase in KE + increase in PE = work done

$$\frac{1}{2}(4)v^2 - 4 \times 10 \times 1 = -21.652 \dots \times 1$$

$$2v^2 = 18.347 \dots$$

$$v^2 = 9.173 \dots$$

$v = 3.028 \dots$ so the speed of the box when it has moved 1 m up the slope is 3.03 m s⁻¹

Begin by finding the value of the tension in the rope by using Newton's second law.
 Next use the work-energy principle on the 4 kg mass only, remember that because the tension acts in a direction opposite to the motion, the work done by the tension is negative.
 You could instead use the work-energy principle on the 2 kg mass only but the PE is easier to work out for the 4 kg mass! Both masses have the same speed when the box has moved 1 m up the slope.

8

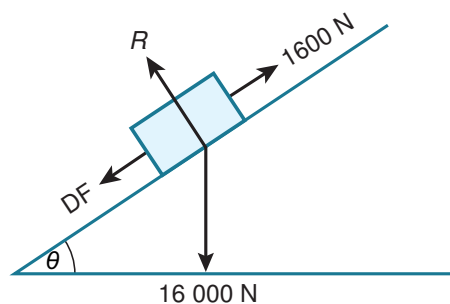

a Use driving force = power \div speed

$$DF = \frac{24000}{20} = 1200 \text{ N}$$

- b Use Newton's second law (parallel to and down the slope).

$$1200 - 1600 + 1600 \times 10 \times \sin \theta = 0$$

$$16000 \sin \theta = 400$$

$$\sin \theta = \frac{400}{16000} = \frac{1}{40} = 0.025$$

When the car is travelling at a constant 20 m s^{-1} the acceleration will be zero in the Newton's second law equation.

- 9 i Gain in KE = $\frac{1}{2}(14000)(24^2) = 4\,032\,000 \text{ J}$ or 4030 kJ
 Loss in PE = $14\,000 \times 10 \times 300 \sin \theta = 42\,000\,000 \sin \theta \text{ J}$ or $42\,000 \sin \theta \text{ kJ}$
- ii Increase in KE + increase in PE = work done
 $4\,032\,000 - 42\,000\,000 \sin \theta = 5\,000\,000 - 4800(400 + 300)$
 $42\,000\,000 \sin \theta = 2\,392\,000$
 $\sin \theta = 0.05695 \dots$
 $\theta = 3.26489 \dots = 3.26$

The work done is positive for the driving force and negative for the resistive force. Remember to use $WD = Fd$ for the resistive force as only the value of the force is given, not the work done.

10

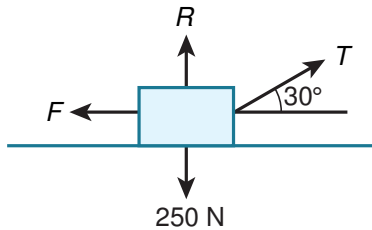

- a Newton's second law (vertically)
 $R - 250 + T \sin 30 = 0$ so $R = 250 - 0.5T$
 $F = \mu R = 0.25(250 - 0.5T)$
 Work done against friction = $Fd = 0.25(250 - 0.5T)(5) = 0.625(500 - T) \text{ J}$
- b Let the initial speed be u and the speed after travelling 5 m be $u + 2$
 Then the average of the initial and final speeds is
 $(u + u + 2) \div 2 = u + 1$
 Increase in KE = $\frac{1}{2}(25)(u + 2)^2 - \frac{1}{2}(25)u^2 = 12.5(u^2 + 4u + 4 - u^2)$
 $= 12.5(4u + 4) = 50(u + 1)$
 Work done against friction = $0.625(500 - T)$ from part a
 Work done by tension = $T \cos 30(5) = 5T \cos 30$
 $50(u + 1) = 5T \cos 30 - 0.625(500 - T)$
 $u + 1 = 0.1T \cos 30 - 0.0125(500 - T) = 0.0991T - 6.25$

Don't forget when using Newton's second law to find the normal contact force to include the vertical component of the tension.

- 11 i Gain in KE of the system = $\frac{1}{2}(5)v^2 + \frac{1}{2}(16)v^2 = 10.5v^2 \text{ J}$
- ii a Loss in PE of the system = loss in PE of B - gain in PE of A
 $= 16 \times 10 \times x - 5 \times 10 \times x \sin 30 = 160x - 25x = 135x \text{ J}$

- b Work done against friction = Fd
 Newton's second law (perpendicular to the plane)
 $R - 50 \cos 30 = 0$ so $R = 50 \cos 30$
 $F = \mu R = \frac{50 \cos 30}{\sqrt{3}} = 25 \text{ N}$
 Work done against friction = $Fd = 25x \text{ J}$

iii Using the work–energy principle for the whole system

Gain in KE + gain in PE = work done

$$10.5v^2 - 135x = -25x$$

$$10.5v^2 = 110x$$

$$21v^2 = 220x \text{ as required.}$$

As you are considering the whole system when applying the work–energy principle, you do not need to consider the work done by the tension. The work done by the tension for block A is of the same magnitude but opposite in sign to the work done by the tension for block B , so these will cancel each other.

12

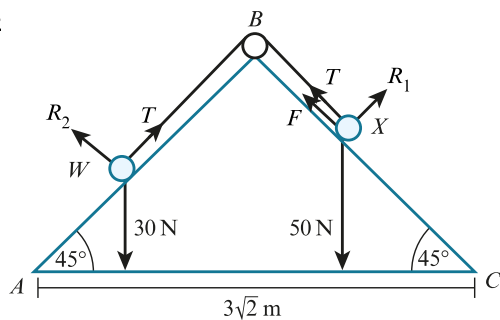

a Newton's second law on X (perpendicular to the plane)

$$R_1 - 50 \cos 45 = 0 \text{ so } R_1 = 50 \cos 45$$

$$F = \mu R = \frac{50 \cos 45}{\sqrt{2}} = 12.5 \text{ N}$$

$$\text{Work done against friction} = Fd = 12.5x \text{ J}$$

b Change in the total PE = loss in PE of X – gain in PE of W

$$= 5 \times 10 \times x \sin 45 - 3 \times 10 \times x \sin 45 = 20x \sin 45 = \frac{20x}{\sqrt{2}} = 10\sqrt{2}x = 14.1x \text{ J}$$

c Using the work–energy principle

Gain in KE + gain in PE = work done

$$\frac{1}{2}(3)v^2 + \frac{1}{2}(5)v^2 - 10\sqrt{2}x = -12.5x$$

Find the distance X has travelled when it reaches the ground.

From the diagram $AB = 3\sqrt{2} \cos 45 = 3 \text{ m}$. The length of the string is 4 m, and W begins at A , so X begins $4 - 3 = 1 \text{ m}$ from B .

When X reaches the ground, it has travelled $3 - 1 = 2 \text{ m}$, so $x = 2$.

$$\frac{1}{2}(3)v^2 + \frac{1}{2}(5)v^2 - 20\sqrt{2} = -25$$

$$4v^2 = 20\sqrt{2} - 25$$

$$v^2 = 0.8210 \dots$$

$$v = 0.9061 \dots \text{ so the speed of the particles is } 0.906 \text{ m s}^{-1}$$

d The work done by the tension in pulling W up slope AB is cancelled by work done against the tension when X slides down BC .

CROSS-TOPIC REVIEW EXERCISE 3

- 1 For the motion before the bounce

$$u = 0, s = 0.45, a = 10$$

$$\text{Using } v^2 = u^2 + 2as$$

$$v^2 = 0^2 + 2(10)(0.45) = 9$$

$$v = 3 \text{ m s}^{-1}$$

For the motion after the bounce

$$v = 0, s = -0.2, a = 10$$

$$\text{Using } v^2 = u^2 + 2as$$

$$0^2 = u^2 + 2(10)(-0.2)$$

$$u^2 = 4$$

$$u = -2 \text{ m s}^{-1}$$

u is negative as the ball is travelling upwards at this point.

$$\text{Momentum after bounce} - \text{momentum before bounce} = 0.5(-2 - 3) = 0.5(-5) = -2.5 \text{ Ns}$$

So, change in momentum is 2.5 Ns

Use equations of constant acceleration to find the speed of the ball just before the bounce and just after the bounce. You can then find the change in momentum that occurs during the bounce.

- 2 $u = 0, s = 10, t = 6$

$$\text{Using } s = ut + \frac{1}{2}at^2$$

$$10 = \frac{1}{2}a(6^2)$$

$$18a = 10$$

$$a = \frac{5}{9} \text{ m s}^{-2}$$

Newton's second law (parallel to and up the plane)

$$T - 30 \sin 8 = 3 \left(\frac{5}{9} \right)$$

$$T = 30 \sin 8 + 3 \left(\frac{5}{9} \right) = 5.8418 \dots$$

$$\text{Work done} = Fd = 5.8418 \dots \times 10 = 58.418 \dots = 58.4 \text{ J}$$

Use equations of constant acceleration (which you can since T is constant and so a is constant) to find the acceleration of the box, then use Newton's second law to find the tension and hence the work done.

- 3

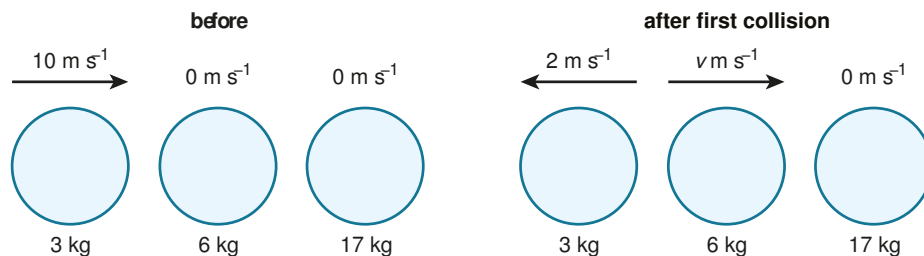

$$\text{Total momentum before any collisions} = 3 \times 10 = 30$$

$$\text{Total momentum after first collision} = 6v + 3 \times (-2) = 6v - 6$$

$$30 = 6v - 6$$

$$6v = 36$$

$$v = 6 \text{ m s}^{-1}$$

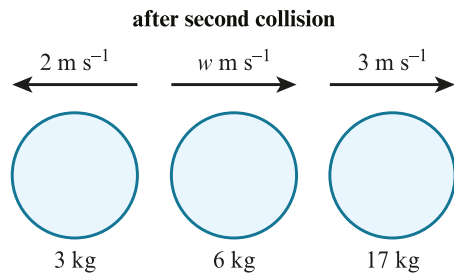

Total momentum after second collision = $3 \times (-2) + 6w + 17 \times 3 = 6w + 45$, assuming C is moving away from A at this point.

$$30 = 6w + 45$$

$$6w = -15$$

$w = -2.5 \text{ m s}^{-1}$ so B is moving to the left, towards A .

So after the final collision, C is moving to the right; A and B are moving to the left. B is moving faster than A and so there will be another collision between A and B .

So C will not collide again, and as the speed of B is greater than the speed of A , B will catch up with and collide with A .

- 4 a Maximum speed = 12 m s^{-1}

At maximum speed, acceleration = 0.

Maximum power = driving force \times maximum speed

Driving force = $600 \div 12 = 50 \text{ N}$

Resultant force = $50 - \text{resistance} = 0$ as the acceleration = 0

Resistance = 50 N

- b Use driving force = power \div speed and Newton's second law (horizontally in the direction of motion).

$$\begin{aligned} \text{DF} - R &= ma \\ \frac{600}{v} - 50 &= (80)(0.625) \\ \frac{600}{v} - 50 &= 50 \\ \frac{600}{v} &= 100 \end{aligned}$$

$$v = 600 \div 100 = 6 \text{ m s}^{-1}$$

- 5 a Let the speed of the coalesced particle be v .

Momentum before = $3 \times 4 = 12$

Momentum after = $8v$

$$12 = 8v$$

$$v = 1.5 \text{ m s}^{-1}$$

- b Remember coalesce means the particles join together on impact and move as a single object.

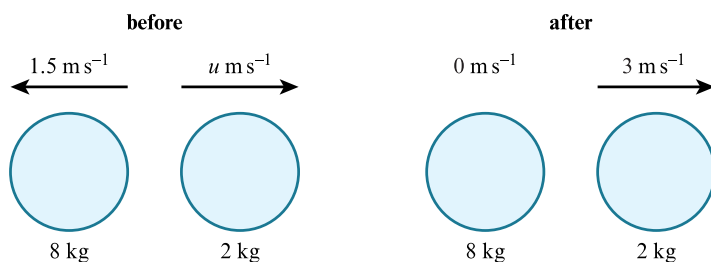

After the second collision, as the coalesced particles remain stationary, the particle of mass 2 kg cannot pass through the coalesced particles so must be travelling to the right as shown in the diagram.

Let the speed of the 2 kg particle before the collision be u , and assume it is moving away from the coalesced particles before the collision, as shown in the diagram.

$$\text{Momentum before} = 8 \times 1.5 + 2(u) = 12 + 2u$$

$$\text{Momentum after} = 2 \times 3 = 6$$

$$12 + 2u = 6$$

$$2u = -6$$

$$u = -3$$

So the speed of the 2 kg particle before the collision is 3 m s^{-1} in the direction towards the coalesced particles.

By assuming the 2 kg particle is moving away from the coalesced particles, you have found it has a negative velocity, which means it is moving towards the coalesced particles.

6 a $20 \text{ kW} = 20\,000 \text{ W}$

$$\text{Power} = \text{driving force} \times \text{speed}$$

$$20\,000 = \text{driving force} \times \text{speed}$$

$$\text{Driving force} = \frac{20\,000}{v}$$

Use Newton's second law in the direction of motion, remembering as the car is travelling with constant speed the acceleration is zero.

$$DF - R = ma$$

$$\frac{20\,000}{v} - 800 = 0$$

$$v = 20\,000 \div 800 = 25 \text{ m s}^{-1}$$

$$\text{Distance} = \text{speed} \times \text{time} = 25 \times 12 = 300 \text{ m}$$

b Let the distance BC be s .

$$\text{Increase in KE} = \text{work done by the engine} - \text{work done against resistance}$$

$$0.5 \times 1200 (28^2 - 25^2) = \text{Power} \times \text{time taken} - Fd$$

$$0.5 \times 1200 (28^2 - 25^2) = 24\,000 \times 37 - 800s$$

$$95\,400 = 888\,000 - 800s$$

$$800s = 796\,600$$

$$s = 990.75 \dots = 991 \text{ m}$$

7 a Gain in KE = Loss in PE

$$\frac{1}{2}mv^2 = mgh$$

$$0.5 \times 2 \times v^2 = 2 \times 10 \times 3.2$$

$$v^2 = 64$$

$$v = 8 \text{ so the speed of the particle at } B \text{ is } 8 \text{ m s}^{-1}$$

As you have a closed system of conservative forces, the work-energy principle becomes gain in KE = loss in PE (the conservation of mechanical energy).

b Decrease in KE = work done against resistance

$$\text{Work done against resistance} = 0.5 \times 2 (8^2 - 4^2) = 64 - 16 = 48 \text{ J}$$

c Let the maximum vertical height of D above BC be h .

$$\text{Loss in KE} = \text{Gain in PE}$$

$$0.5 \times 2 (4^2) = 2 \times 10h$$

$$20h = 16$$

$$h = 0.8 \text{ m}$$

8 a Increase in KE + increase in PE = work done by the car's engine - work done against resistance

$$\frac{1}{2}(2000)(16^2) - \frac{1}{2}(2000)(20^2) + 2000 \times 10 \times 200 \sin \theta = 256\,000 - 200R$$

$$-144\,000 + 250\,000 = 256\,000 - 200R$$

$$200R = 150\,000$$

$$R = 750\text{ N}$$

Remember the work done by the car's engine is already given in the question, but the work done against resistance is found from Rd .

- b Increase in KE + increase in PE = work done by the car's engine – work done against resistance

$$\frac{1}{2}(2000)(12^2) - \frac{1}{2}(2000)(16^2) + 2000 \times 10 \times s \sin \theta = 388\,000 - 750s$$

$$-112\,000 + 1250s = 388\,000 - 750s$$

$$2000s = 500\,000$$

$$s = 250\text{ m}$$

- 9 a Newton's second law (vertically for P)

$$R - 40 = 0 \text{ so } R = 40$$

$$F = \mu R = 0.4(40) = 16\text{ N}$$

Newton's second law (horizontally for P)

$$-F = 4a$$

$$-16 = 4a$$

$$a = -4\text{ m s}^{-2}$$

$$u = 9, s = 7, a = -4$$

$$\text{Using } v^2 = u^2 + 2as$$

$$v^2 = 9^2 + 2(-4)(7) = 25$$

$$v = 5$$

So the speed of P immediately before the collision is 5 m s^{-1} as required.

Newton's second law (vertically for Q)

$$R - 30 = 0 \text{ so } R = 30$$

$$F = \mu R = 0.4(30) = 12\text{ N}$$

Newton's second law (horizontally for Q)

$$-F = 3a$$

$$-12 = 3a$$

$$a = -4\text{ m s}^{-2}$$

$$v = 0, s = 2, a = -4$$

$$\text{Using } v^2 = u^2 + 2as$$

$$0^2 = u^2 + 2(-4)(2)$$

$$u^2 = 16$$

$$u = 4$$

So the speed of Q immediately after the collision is 4 m s^{-1} .

Use Newton's second law vertically and horizontally for each particle to find the accelerations, then equations of constant acceleration to find the speeds.

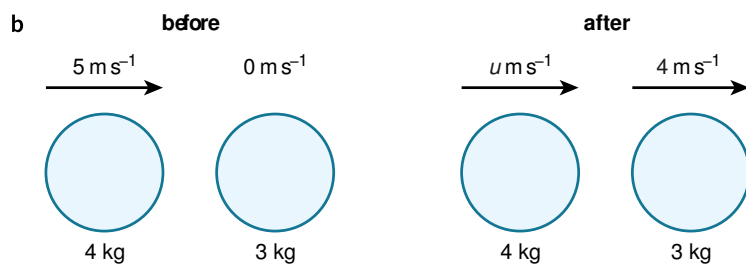

Let the speed of particle P after the collision be u .

$$\text{Momentum before} = 4 \times 5 = 20$$

$$\text{Momentum after} = 4u + 3 \times 4 = 4u + 12$$

$$20 = 4u + 12$$

$$4u = 8$$

$$u = 2 \text{ m s}^{-1}$$

$$u = 2, v = 0, a = -4$$

Using $v^2 = u^2 + 2as$

$$0^2 = 2^2 + 2(-4)s$$

$$8s = 4$$

$$s = 0.5 \text{ m}$$

So P has travelled 2 m before it comes to rest, Q has travelled 0.5 m before it comes to rest, and both are travelling in the same positive direction.

So the distance between P and Q when both have come to rest is $2 - 0.5 = 1.5 \text{ m}$

In answering part **b** it's assumed both particles are travelling in the positive direction after the collision. At least one particle must be, since the overall momentum is positive.

Particle Q has a speed of 4 m s^{-1} after the collision. Particle P is found to have a speed of 2 m s^{-1} after the collision, and as Q cannot pass through P both must be travelling in the same positive direction.

10 i

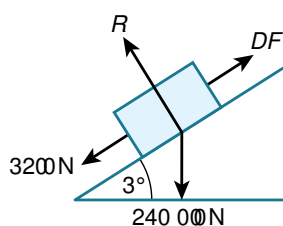

Use driving force = power \div speed and Newton's second law (parallel to and up the slope)

$$\frac{P}{25} - 3200 - 24000(10) \sin 3 = (24000)(0.2)$$

$$\frac{P}{25} = 20560.62\dots$$

$$P = 514015.7\dots = 514000 \text{ W or } 514 \text{ kW}$$

When using Newton's second law, don't forget the component of weight parallel to the slope.

ii As the lorry travels at a steady speed, acceleration = 0

Again, use driving force = power \div speed and Newton's second law (parallel to and up the slope)

$$\frac{500000}{v} - 3200 - 24000(10) \sin 3 = 0$$

$$\frac{500000}{v} = 15760.62\dots\dots$$

$$v = 31.724\dots = 31.7 \text{ m s}^{-1}$$

11 i The work done against friction = $Fd = 40 \times 36 = 1440 \text{ J}$

ii The change in gravitational potential energy of the box = $mgh = 25 \times 10 \times 36 \sin 20$
 $= 3078.18\dots = 3080 \text{ J}$

iii Work done by the pulling force = gain in PE + work done against friction
 $= 3078.18\dots + 1440 = 4518.18\dots$
 $= 4520 \text{ J}$

Use the work-energy principle, remembering that gain in KE is zero as the box is travelling at a constant speed.

12 i As the car travels at a steady speed, acceleration = 0

Use driving force = power \div speed and Newton's second law (horizontally in the direction of motion)

$$\frac{P}{40} - 300 = 0$$

$$\frac{P}{40} = 300$$

$$P = 12000 \text{ W or } 12 \text{ kW}$$

When using Newton's second law here, there is no component of weight in the direction of motion, unlike in question 10.

- ii As the engine is working at 90% of the power from part i, the power is now $0.9 \times 12000 = 10800 \text{ W}$.

Use driving force = power \div speed and Newton's second law (horizontally in the direction of motion)

$$\frac{10800}{25} - 300 = 1000a$$

$$432 - 300 = 1000a$$

$$1000a = 132$$

$$a = 0.132 \text{ m s}^{-2}$$

- 13 i Work done by the pulling force = $Fd \cos \theta = 50 \times 20 \cos 10 = 984.80 \dots = 985 \text{ J}$

- ii Increase in KE = work done by the pulling force – work done against resistance

$$0.5 \times 25v^2 = 984.80 \dots - 30 \times 20$$

$$12.5v^2 = 384.80 \dots$$

$$v^2 = 30.784 \dots$$

$$v = 5.548 \dots = 5.55 \text{ m s}^{-1}$$

- iii Greatest power exerted by the 50 N force = driving force \times speed

$$= 50 \cos 10 \times 5.548 \dots = 273.20 \dots = 273 \text{ W}$$

As the pulling and resistive forces are constant, the greatest power occurs at the greatest speed. The block is accelerating throughout the motion so the greatest speed will occur at the end of the motion (when $s = 20 \text{ m}$).

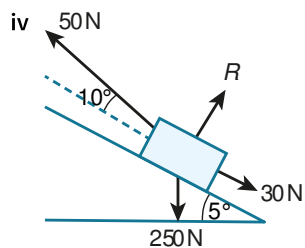

Newton's second law (parallel to and up the plane)

$$50 \cos 10 - 30 - 25g \sin 5 = 25a$$

$$25a = -2.5485 \dots$$

$$a = -0.1019 \dots \text{ m s}^{-2}$$

$$u = 5.548 \dots, a = -0.1019 \dots, v = 0$$

Using $v = u + at$

$$0 = 5.548 \dots + (-0.1019 \dots) t$$

$$t = 54.426 \dots = 54.4 \text{ s}$$

PRACTICE EXAM-STYLE PAPER

All worked solutions within this resource have been written by the author. In examinations, the way marks are awarded may be different.

1

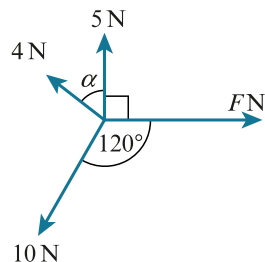

Resolving vertically:

$$5 + 4 \cos \alpha = 10 \cos 30$$

$$\cos \alpha = \frac{10 \cos 30 - 5}{4} = 0.915\dots$$

$$\alpha = 23.785\dots = 23.8^\circ \text{ as required.}$$

Resolving horizontally:

$$\begin{aligned} F &= 4 \sin \alpha + 10 \sin 30 \\ &= 6.613\dots = 6.61 \text{ N} \end{aligned}$$

By resolving vertically before horizontally you can find the value of α straight away as F has no vertical component.

2 a $60 \text{ kW} = 60\,000 \text{ W}$

Power = driving force \times speed

$$60\,000 = \text{driving force} \times 32$$

$$\text{Driving force} = 60\,000 \div 32 = 1875$$

Resultant force = driving force $-$ resistance

At the maximum speed, acceleration = 0 so at this point, resultant force = 0

$$\text{So resistance} = \text{driving force} = 1875 \text{ N}$$

b Work done by the engine = $Fd = 1875 \times 200 = 375\,000 = 375 \text{ kJ}$

3

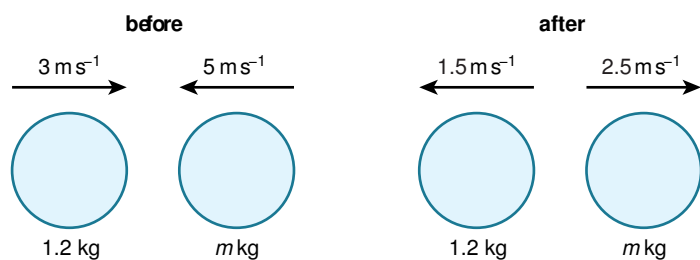

a Total momentum before = $1.2 \times 3 - 5m = 3.6 - 5m$

$$\text{Total momentum after} = 2.5m + 1.2 \times (-1.5) = 2.5m - 1.8$$

$$3.6 - 5m = 2.5m - 1.8$$

$$5.4 = 7.5m$$

$$m = 0.72 \text{ kg}$$

b Loss of KE in the impact = KE lost by the ball of mass 1.2 kg + the KE lost by the ball of mass 0.72 kg.

$$= 0.5 \times 1.2 \times (3^2 - 1.5^2) + 0.5 \times 0.72 \times (5^2 - 2.5^2)$$

$$= 4.05 + 6.75$$

$$= 10.8 \text{ J}$$

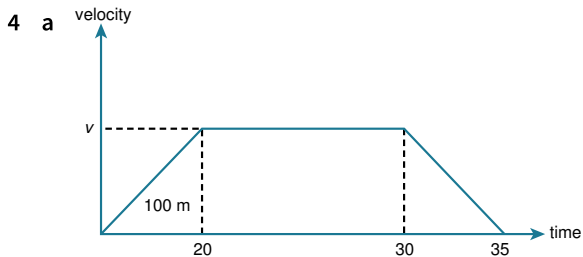

Area of first triangle = 100

Let the speed reached after 20 s be v , then $20v \div 2 = 100$.

$$v = 10 \text{ m s}^{-1}$$

Total distance = area of the trapezium = $0.5(35 + 10) \times 10 = 225 \text{ m}$

You may find this easier if you draw a velocity–time graph. Remember the area between the graph and the time axis represents the displacement and the gradient represents the acceleration.

b From the gradient of the graph, $a = 10 \div 20 = 0.5 \text{ m s}^{-2}$

After 10 s her velocity using $v = u + at$ will be $v = 0.5 \times 10 = 5 \text{ m s}^{-1}$

The total distance she travels is $5 \times 10 \div 2 + 5t = 100$, where t is the time she travels at a constant speed.

$$25 + 5t = 100$$

$$5t = 75$$

$$t = 15 \text{ s}$$

Then the total time taken is $15 + 10 = 25 \text{ s}$

The total distance travelled is given by the area of the triangle for when the girl is accelerating plus the area of the rectangle when she is travelling at a constant speed.

5 a $a_1 = \frac{dv_1}{dt} = \frac{2t}{3} - \frac{t^2}{9}$

At $a_1 = 0$, $t \left(\frac{2}{3} - \frac{t}{9} \right) = 0$

($t = 0$), $\frac{2}{3} = \frac{t}{9}$ so $t = 6 \text{ s}$

When $t = 6$, $V = \frac{6^2}{3} - \frac{6^3}{27} = 12 - 8 = 4 \text{ m s}^{-1}$

Find the time when $a_1 = 0$ and then find the velocity at this time. Remember the velocity is variable so equations of constant acceleration cannot be used.

b $v_2 = \int a_2 dt = \int (0.048T^2 - 0.008T^3) dt = 0.016T^3 - 0.002T^4 + c$

When $T = 0$, $v_2 = 4$ so $c = 4$

$$v_2 = 0.016T^3 - 0.002T^4 + 4$$

When $T = 10$, $v_2 = 0.016(10^3) - 0.002(10^4) + 4 = 16 - 20 + 4 = 0$ as required

c The total time for which the man runs is given by:

6 s (the time found in part a)

10 s (the time given in part b)

The middle section when he runs at a constant speed of $V (= 4 \text{ m s}^{-1})$ for 50 m, which will take him $50 \div 4 = 12.5 \text{ s}$

So his total time is $6 + 10 + 12.5 = 28.5 \text{ s}$

6

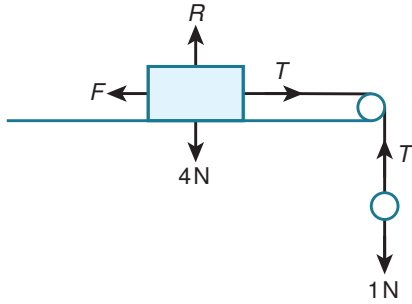

a $u = 0, t = 2, s = 1$

Using $s = ut + \frac{1}{2}at^2$

$$1 = \frac{1}{2}a(2)^2$$

$$a = 0.5 \text{ m s}^{-2}$$

Use Newton's second law horizontally to the right on particle A

$$T - F = 0.4 \times 0.5 = 0.2 \dots\dots [1]$$

Use Newton's second law vertically downwards on particle B

$$1 - T = 0.1 \times 0.5 = 0.05 \dots\dots [2]$$

[1] + [2] gives:

$$1 - F = 0.25$$

$$F = 0.75 \text{ N}$$

Use equations of constant acceleration to find the acceleration of the system. Also, use Newton's second law on each particle in the direction of motion to find the frictional force acting on particle A.

b For the motion whilst under tension, when B reaches the floor:

$$u = 0, t = 2, s = 1, a = 0.5$$

Using $v = u + at$

$$v = 0.5(2)$$

$$v = 1 \text{ m s}^{-1}$$

In the second part of the motion there is no tension.

So, using Newton's second law horizontally to the right on particle A:

$$-F = 0.4a$$

$$F = 0.75 \text{ N (from part a)}$$

$$\text{So, } a = -0.75 \div 0.4 = -1.875 \text{ m s}^{-2}$$

$$u = 1, v = 0, a = -1.875$$

Using $v^2 = u^2 + 2as$

$$0^2 = 1^2 + 2(-1.875)s$$

$$3.75s = 1$$

$$s = 0.26$$

$$\text{So the total distance travelled is } 0.26 + 1 = 1.26 = 1.27 \text{ m}$$

The motion of particle A is in two sections; the first whilst under tension, when the acceleration is as in part a. You can use this to find the velocity when particle B reaches the floor. In the second section, A is moving with only the frictional force acting, so use Newton's second law again to find the new acceleration for A.

7

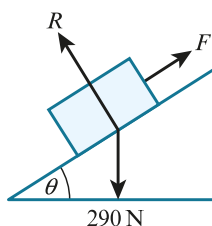

a Newton's second law (perpendicular to the plane)

$$R - 290 \cos \theta = 0 \text{ so } R = 290 \cos \theta$$

$$F = \mu R = 290 \cos \theta \div 25 = 11.6 \cos \theta$$

Newton's second law (parallel to and down the plane)

$$290 \sin \theta - 11.6 \cos \theta = 29a$$

$$34 - 11.52 = 29a$$

$$29a = 22.48$$

$$a = 0.7751 \dots = 0.775 \text{ m s}^{-2}$$

b Loss in KE of the crate = $0.5 \times 29 \times (0.3^2 - 0.1^2) = 1.16 \text{ J}$

c Loss in PE of the crate = $29 \times 10 \times 0.58 \sin \theta = 19.7 \text{ J}$

d Let the average resistance force on the crate be R .

Increase in KE + increase in PE = work done

$$-1.16 - 19.72 = -0.58R$$

$$0.58R = 20.88$$

$$R = 36 \text{ N}$$

The sign is negative for the work done in the equation as the work done is against the direction of motion.

CAMBRIDGE
UNIVERSITY PRESS

University Printing House, Cambridge CB2 8BS, United Kingdom
One Liberty Plaza, 20th Floor, New York, NY 10006, USA
477 Williamstown Road, Port Melbourne, VIC 3207, Australia
314–321, 3rd Floor, Plot 3, Splendor Forum, Jasola District Centre, New Delhi – 110025, India
79 Anson Road, #06–04/06, Singapore 079906

Cambridge University Press is part of the University of Cambridge.

It furthers the University's mission by disseminating knowledge in the pursuit of education, learning and research at the highest international levels of excellence.

www.cambridge.org

Information on this title: www.cambridge.org/9781108758925

© Cambridge University Press 2020

This publication is in copyright. Subject to statutory exception and to the provisions of relevant collective licensing agreements, no reproduction of any part may take place without the written permission of Cambridge University Press.

First published 2020

20 19 18 17 16 15 14 13 12 11 10 9 8 7 6 5 4 3 2 1

A catalogue record for this publication is available from the British Library

ISBN 9781108758925 Paperback with Elevate Edition

Cambridge University Press has no responsibility for the persistence or accuracy of URLs for external or third-party internet websites referred to in this publication, and does not guarantee that any content on such websites is, or will remain, accurate or appropriate. Information regarding prices, travel timetables, and other factual information given in this work is correct at the time of first printing but Cambridge University Press does not guarantee the accuracy of such information thereafter.

All worked solutions within this resource have been written by the authors.

In examinations, the way marks are awarded may be different.

NOTICE TO TEACHERS IN THE UK

It is illegal to reproduce any part of this work in material form (including photocopying and electronic storage) except under the following circumstances:

- (i) where you are abiding by a licence granted to your school or institution by the Copyright Licensing Agency;
- (ii) where no such licence exists, or where you wish to exceed the terms of a licence, and you have gained the written permission of Cambridge University Press;
- (iii) where you are allowed to reproduce without permission under the provisions of Chapter 3 of the Copyright, Designs and Patents Act 1988, which covers, for example, the reproduction of short passages within certain types of educational anthology and reproduction for the purposes of setting examination questions.



This resource is endorsed by
Cambridge Assessment International Education

- ✓ Provides learner support for Paper 4 of the syllabus for examination from 2020
- ✓ Has passed Cambridge International's rigorous quality-assurance process
- ✓ Developed by subject experts
- ✓ For Cambridge schools worldwide